



SAN FRANCISCO PLANNING DEPARTMENT

Permit to Alter Case Report

HEARING DATE: NOVEMBER 3, 2010

Hearing Date: November 3, 2010
Filing Date: October 25, 2010
Case No.: **2010.0964H**
Project Address: **211 Sutter Street**
Conservation District: Kearny-Market-Mason-Sutter Conservation District
Category: Category I – Sherman Clay & Company Building
Zoning: C-3-O (Downtown Office)
80-130-F Height and Bulk District
Block/Lot: 0293/ 001
Applicant: Tom Lewis
Tom Lewis Restoration
768 Brannan Street
San Francisco, CA 94103
Staff Contact Pilar LaValley - (415) 575-9084
pilar.lavalley@sfgov.org
Reviewed By Tim Frye – (415) 575-6822
tim.frye@sfgov.org

1650 Mission St.
Suite 400
San Francisco,
CA 94103-2479

Reception:
415.558.6378

Fax:
415.558.6409

Planning
Information:
415.558.6377

PROPERTY DESCRIPTION

Historically known as the Sherman Clay & Company Building, the subject building is located at 211 Sutter Street (Assessor's Block 0293, Lot 001) at the southwest corner of Sutter and Kearny Streets. It is a Category I (Significant) Building within the Kearny-Market-Mason-Sutter Conservation District. The building is located within a C-3-O (Downtown Office) Zoning District with an 80-130-F Height and Bulk limit.

211 Sutter Street was designed by noted Bay Area architect George Applegarth in 1907. It is an eleven-story steel frame structure that is clad in glazed terra cotta. The base of the building was modernized sometime in the recent past; however, the upper-floors retain a high level of historic integrity. The building façade is designed in a tripartite arrangement of base, shaft, and capital and displays a variety of Neoclassical motifs.

PROJECT DESCRIPTION

The proposed work includes the replacement of the historic cornice along the Sutter Street elevation with a glass fiber reinforced concrete (GFRC) cornice consisting of panelized and cast units, and selective spot replacement of terra cotta with GFRC at the 8th and 9th -floors. Spalled or damaged terra cotta units along the Sutter Street elevation at the cornice, 8th, and 9th-floors will be repaired in place using epoxy or helical anchors.

PROJECT BACKGROUND

The Historic Preservation Commission granted, with conditions, a Permit to Alter for terra cotta replacement and repair on the Kearny Street elevation at its July 7, 2010 hearing (Case No. 2010.0448H, Motion No. 0072). Since that time, the Project Sponsor has determined that the cornice at the Sutter Street elevation also requires replacement due to extensive water damage and corrosion of the structural steel. The proposed project has subsequently been revised and is seeking a new Permit to Alter for work proposed on the Sutter Street elevation.

The previous approval was conditioned to require that the Project Sponsor submit shop drawings for review and approval by Department staff prior to building permit approval, and that Department staff and the Historic Preservation Commission would review and approve site mock ups and glaze samples for the proposed replacement GFRC. To address the latter condition, staff has met with the Project Sponsor (and Page & Turnbull) and reviewed at the site proposed GFRC base color samples, color and finish samples, and joint sealant samples. Based on this review, staff recommended that the Project Sponsor bring these samples to the Commission for review and comment during the hearing on the current application. With feedback from the site visit and Commission comments, staff recommended that, at a future date and prior to installation (or production) of the replacement material, an on-site mock up be prepared for review and approval by staff, and Commission members, if desired. The results of the site mock-up and all glaze samples shall be presented at a future hearing to the Historic Preservation Commission for review and approval prior to the production of the replacement units and the approval of the permit application by the Planning Department.

The recent site visit review also included examples of cast GFRC units (head and floret) based upon molds from existing terra cotta units. Based on this review, staff feels comfortable that the GFRC casting will accurately reproduce details and reveals from the original terra cotta.

The current shop drawings provided by the Project Sponsor are inadequate as neither they nor the architectural plans provide sufficient detail regarding proposed expansion and faux joints in the new panelized GFRC units.

OTHER ACTIONS REQUIRED

A Building Permit is required.

COMPLIANCE WITH THE PLANNING CODE PROVISIONS

The proposed project is in compliance with all other provisions of the Planning Code.

APPLICABLE PRESERVATION STANDARDS

ARTICLE 11

Proposition J received voter approval in November 2008 and gives the Historic Preservation Commission (HPC) authority to approve, disapprove, or modify Permit to Alter applications for designated Significant or Contributory buildings. In appraising a proposal for a Permit to Alter, the Historic Preservation Commission should consider the factors of architectural style, design, arrangement, texture,

materials, color, and other pertinent issues. Section 1111.6 of the Planning Code outlines standards and requirements for the HPC to consider when reviewing a Permit to Alter.

ARTICLE 11 – Appendix E– The Kearny-Market-Mason-Sutter Conservation District

In reviewing an application for a Permit to Alter, the Historic Preservation Commission must consider whether the proposed work would be compatible with the character of the Kearny-Market-Mason-Sutter Conservation District as described in Appendix E of Article 11 of the Planning Code and the standards and requirements for review as outlined in Section 1111.6 of the Planning Code (attached).

SECTION 1111.6 OF THE PLANNING CODE

Section 1111.6 of the Planning Code outlines the specific standards and requirements the Historic Preservation Commission shall use when evaluating permits to alter. These standards, in relevant part(s), are listed below:

(a) The proposed alteration shall be consistent with and appropriate for the effectuation of the purposes of this Article 11.

(b) For Significant Buildings - Categories I and II, and for Contributory Buildings - Categories III and IV, proposed alterations of structural elements and exterior features shall be consistent with the architectural character of the building, and shall comply with the following specific requirements:

(1) The distinguishing original qualities or character of the building may not be damaged or destroyed. Any distinctive architectural feature which affects the overall appearance of the building shall not be removed or altered unless it is the only feasible means to protect the public safety.

The cornice on the Sutter Street elevation requires removal due to severe deterioration of the underlying steel frame. The corrosion was caused by a gutter system behind the cornice which lacked the proper slope and allowed water to eventually penetrate into the building's structural system.

The architectural character of the subject building will be maintained by using repair methods that are appropriate and that minimize the loss of additional historic fabric and through the installation of replacement features using a compatible substitute material. As proposed, the existing terra cotta cornice will be replaced with glass fiber reinforced concrete (GFRC) units matching as closely as possible the overall appearance, finish, and visual characteristics of the original material.

(2) The integrity of distinctive stylistic features or examples of skilled craftsmanship that characterize a building shall be preserved.

All architectural terra cotta should be salvaged, cleaned, protected, repaired and reinstalled where possible in order to retain as much historic fabric as possible. All units that are beyond repair are

proposed to be replaced with glass fiber reinforced concrete (GFRC) units that will be based on molds of the original features and will be finished to match as closely as possible the overall appearance, finish, and visual characteristics of the original material.

(3) Distinctive architectural features which are to be retained pursuant to Paragraph (1) but which are deteriorated shall be repaired rather than replaced, whenever possible. In the event replacement is necessary, the new material shall match the material being replaced in composition, design, color, texture and other visual qualities. Repair or replacement of missing architectural features shall be based on accurate duplication of features, substantiated by historic, physical or pictorial evidence, if available, rather than on conjectural designs or the availability of different architectural elements from other buildings or structures. Replacement of non-visible structural elements need not match or duplicate the material being replaced.

The Department believes that the proposal should retain and repair as much historic fabric as possible. Where the historic material is beyond repair, it should be replaced in-kind unless not technically or economically feasible.

For architectural features that are beyond repair and require replacement, the feature may be replaced with compatible substitute materials that match the historic fabric in terms of, location, detail, design, scale, plane, texture, and finish.

(6) In the case of Significant Buildings - Category I, any additions to height of the building (including addition of mechanical equipment) shall be limited to one story above the height of the existing roof, shall be compatible with the scale and character of the building, and shall in no event cover more than 75 percent of the roof area.

N/A

PUBLIC/NEIGHBORHOOD INPUT

The Department has received no public input on the project at the date of this report.

ISSUES & OTHER CONSIDERATIONS

None.

STAFF ANALYSIS

Based on the requirements of Article 11, Department has determined the following:

Terra Cotta Repair and Replacement: The details and specifications provided by the Project Sponsor regarding terra cotta repair appear to be consistent with the standard methods for terra cotta repair.

The Department understands the challenges outlined by the Project Sponsor regarding the technical and economic feasibility of using terra cotta as opposed to GFRC. Evaluation of the project indicates that

replacement of the entire cornice with a compatible substitute material, such as GFRC provided it is accurately modeled on original features and has an appropriate finish, would be appropriate.

In the previous Permit to Alter case, staff had concerns regarding spot replacement with a substitute material. Based on our interpretation of the *Secretary of the Interior's Standards*, the Department felt that if the entire cornice was beyond repair and required replacement, there would be a stronger argument for proposing a substitute material as opposed to terra cotta. The replacement of an entire architectural feature (rather than spot replacement) in a substitute material would not likely result in a noticeable visual divergence from the historic terra cotta. Given that the scope of work has been revised such that the entire cornice would be replaced, it appears that use of a compatible substitute material would be appropriate in this particular application.

While use of the substitute material may be appropriate, the Department has had concerns with the long-term performance of the proposed GFRC, which have been partially addressed by the Project Sponsor.

Color, Texture, and Finish: The information provided by the Project Sponsor and the Memorandum submitted by Page & Turnbull, dated June 29, 2010, does support using GFRC in circumstances where the exterior of the terra cotta unit has a *brownstone* finish; however, the Department is concerned that the finish applied to the GFRC to replicate the glazed terra cotta as part of this proposal is not appropriate. While the painted finish on the GFRC units may initially match the glazed terra cotta, there is no information that demonstrates that it will age and weather in the same manner as the surrounding historic fabric. Based on the Page & Turnbull report it appears that the finish to the GFRC may require the application of additional coating systems in the future. There is also no information that indicates that the finish applied to the GFRC panels will maintain sheen over an extensive period of time similar to the characteristics of the historic terra cotta units.

To minimize visual impacts should the coating deteriorate over time, the Project Sponsor has reviewed several base color samples for the GFRC and has, with the assistance of Page & Turnbull and Department staff, chosen a color that closely matches that of the existing, cleaned terra cotta. One of the proposed finish samples is an Edison Coating that is the same as used on previous terra cotta repair projects at the building. Staff has asked the Project Sponsor to provide photographs of some of these previous repairs to determine the long-term durability and appearance of this coating/finish.

Casting & Joints: The GFRC panels are proposed to be cast in dimensions that are larger than the individual terra cotta units. Faux joints will be cast as a reveal and may be pointed with mortar to create a joint pattern that matches the historic joints. True joints will be pointed with a urethane sealant to allow for contraction and expansion. The Department is concerned that urethane sealant will weather and discolor in a manner that would detract from the overall design and character of the building. A negative result could be a visually noticeable outline around the GFRC panels and the areas where the GFRC is keyed into the surrounding terra cotta.

The Project Sponsor has provided staff with several types and colors of sealants, which will also be presented to the Commission for review.

ENVIRONMENTAL REVIEW STATUS

The Planning Department has determined that the proposed project is exempt/excluded from environmental review; pursuant to CEQA Guideline Section 15301 (Class One-Maintenance and Repair of Existing facility) because the project is a minor alteration of an existing structure and meets the *Secretary of the Interior's Standards*.

PLANNING DEPARTMENT RECOMMENDATION

Planning Department staff recommends APPROVAL WITH CONDITIONS of the proposed project as it appears to meet the *Secretary of the Interior Standards* for Rehabilitation.

ATTACHMENTS

Draft Motion

Project Sponsor submittal (DVD containing plans, specifications, photographs, etc.)

PL: G:\DOCUMENTS\211 Sutter\Case report.doc



SAN FRANCISCO PLANNING DEPARTMENT

Historic Preservation Commission Draft Motion

Hearing Date: November 3, 2010
Filing Date: October 25, 2010
Case No.: **2010.0964H**
Project Address: **211 Sutter Street**
Conservation District: Kearny-Market-Mason-Sutter Conservation District
Category: Category I – Sherman Clay & Company Building
Zoning: C-3-O (Downtown Office)
80-130-F Height and Bulk District
Block/Lot: 0293/ 001
Applicant: Tom Lewis
Tom Lewis Restoration
768 Brannan Street
San Francisco, CA 94103
Staff Contact: Pilar LaValley - (415) 575-9084
pilar.lavalley@sfgov.org
Reviewed By: Tim Frye – (415) 575-6822
tim.frye@sfgov.org

1650 Mission St.
Suite 400
San Francisco,
CA 94103-2479

Reception:
415.558.6378

Fax:
415.558.6409

Planning
Information:
415.558.6377

ADOPTING FINDINGS FOR A PERMIT TO ALTER FOR MAJOR ALTERATIONS TO A CATEGORY I (SIGNIFICANT) BUILDING, INCLUDING TERRA COTTA REPLACEMENT AT THE 8TH, 9TH, AND 10TH-FLOORS FOR THE PROPERTY LOCATED ON LOT 001 IN ASSESSOR'S BLOCK 0293. THE SUBJECT BUILDING IS WITHIN A C-3-O (DOWNTOWN OFFICE) ZONING DISTRICT, THE KEARNY-MARKET-MASON-SUTTER CONSERVATION DISTRICT, AND AN 80-130-F HEIGHT AND BULK DISTRICT.

PREAMBLE

WHEREAS, on June 11, 2010, TOM LEWIS (Project Sponsor) filed with the City and County of San Francisco Planning Department (Department) Permit to Alter Application No. 2010.0448H to replace terra cotta at the 8th, 9th, and 10th floors on the Kearny Street elevation where the units are failing or access to the structural system behind is required for the building, at 211 Sutter Street, a Category I Building within the Kearny-Market-Mason-Sutter Conservation District.

WHEREAS, on July 7, 2010, the Historic Preservation Commission (Commission) conducted a duly noticed public hearing at a regularly scheduled meeting and approved with conditions the project proposed in Certificate of Appropriateness Application No. 2010.0448H through Motion No. 0072.

WHEREAS, on October 25, 2010, TOM LEWIS (Project Sponsor) filed an application with the San Francisco Planning Department (Department) for a Permit to Alter to replace terra cotta at the 8th, 9th, and 10th floors on the Sutter Street elevation where the units are failing or access to the structural system behind is required for the building, at the subject building located on Lot 001 in Assessor's Block 0293, a Category I Building within the Kearny-Market-Mason-Sutter Conservation District.

WHEREAS, the Project was determined by the Department to be categorically exempt from environmental review. The Commission has reviewed and concurs with said determination.

WHEREAS, on November 3, 2010, the Commission conducted a duly noticed public hearing on the current project, Case No. 2010.0964H (Project) for the Permit to Alter.

WHEREAS, in reviewing the Application, the Commission has had available for its review and consideration case reports, plans, and other materials pertaining to the Project contained in the Department's case files, has reviewed and heard testimony and received materials from interested parties during the public hearing on the Project.

MOVED, that the Commission hereby grants the Permit to Alter, WITH CONDITIONS, and in conformance with the architectural plans dated October 19, 2010 and labeled Exhibit A on file in the docket for Case No. 2010.0964H based on the following condition(s):

Conditions:

1. As part of the building permit, existing elevations, details, and sections along with the proposed shop drawings showing all exterior profiles and dimensions will be forwarded for review and approval by Planning Department Preservation Staff prior to production of the replacement units and the approval of the permit application by the Planning Department.
2. Glaze samples shall be matched from historic terra cotta units that are cleaned using the gentlest means possible and shall include an accurate range of the shade and tone of the building.
3. A mock-up of the glaze samples shall be reviewed by Preservation Planning Staff at the job site prior to review by the Historic Preservation Commission.
4. The results of the site mock-up and all glaze samples shall be presented at a future hearing to the Historic Preservation Commission for review and approval prior to the production of the replacement units and the approval of the permit application by the Planning Department.

FINDINGS

Having reviewed all the materials identified in the recitals above and having heard oral testimony and arguments, this Commission finds, concludes, and determines as follows:

1. The above recitals are accurate and also constitute findings of the Commission.
2. Findings pursuant to Article 11:

The Historical Preservation Commission has determined that the proposed work is compatible with the character of the Kearny-Market-Mason-Sutter Conservation District as described in Appendix E of Article 11 of the Planning Code:

- That the proposal respects the character-defining features of the subject building and within Kearny-Market-Mason-Sutter Conservation District;
- That the architectural character of the subject building will be maintained and those features that affect the building's overall appearance that are removed or repaired shall be done so in-kind.
- All architectural elements and cladding repaired where possible in order to retain as much historic fabric as possible.
- That the integrity of distinctive stylistic features and examples of skilled craftsmanship that characterize the building shall be preserved; and
- That all new materials shall match the historic material in composition, design, color, texture and other visual qualities and shall be based on accurate duplication of features.

For these reasons, the proposal overall, is appropriate for and consistent with the purposes of Article 11, meets the standards of Article 1111.6 of the Planning Code and complies with the *Secretary of the Interior's Standards*.

3. **General Plan Compliance.** The proposed Permit to Alter is, on balance, consistent with the following Objectives and Policies of the General Plan:

I. URBAN DESIGN ELEMENT

THE URBAN DESIGN ELEMENT CONCERNS THE PHYSICAL CHARACTER AND ORDER OF THE CITY, AND THE RELATIONSHIP BETWEEN PEOPLE AND THEIR ENVIRONMENT.

GOALS

The Urban Design Element is concerned both with development and with preservation. It is a concerted effort to recognize the positive attributes of the city, to enhance and conserve those attributes, and to improve the living environment where it is less than satisfactory. The Plan is a definition of quality, a definition based upon human needs.

OBJECTIVE 1

EMPHASIS OF THE CHARACTERISTIC PATTERN WHICH GIVES TO THE CITY AND ITS NEIGHBORHOODS AN IMAGE, A SENSE OF PURPOSE, AND A MEANS OF ORIENTATION.

POLICY 1.3

Recognize that buildings, when seen together, produce a total effect that characterizes the city and its districts.

OBJECTIVE 2

CONSERVATION OF RESOURCES WHICH PROVIDE A SENSE OF NATURE, CONTINUITY WITH THE PAST, AND FREEDOM FROM OVERCROWDING.

POLICY 2.4

Preserve notable landmarks and areas of historic, architectural or aesthetic value, and promote the preservation of other buildings and features that provide continuity with past development.

POLICY 2.5

Use care in remodeling of older buildings, in order to enhance rather than weaken the original character of such buildings.

POLICY 2.7

Recognize and protect outstanding and unique areas that contribute in an extraordinary degree to San Francisco's visual form and character.

The goal of a Permit to Alter is to provide additional oversight for buildings and districts that are architecturally or culturally significant to the City in order to protect the qualities that are associated with that significance.

The proposed project qualifies for a Permit to Alter and therefore furthers these policies and objectives by maintaining and preserving the character-defining features of the KMMS Conservation District for the future enjoyment and education of San Francisco residents and visitors.

1. The proposed project is generally consistent with the eight General Plan priority policies set forth in Section 101.1 in that:

- A) The existing neighborhood-serving retail uses will be preserved and enhanced and future opportunities for resident employment in and ownership of such businesses will be enhanced:

The proposed project is not neighborhood-serving; however, its continued use maintains and strengthens the surrounding retail uses, many of them are locally-owned, by bringing visitors to the area.

- B) The existing housing and neighborhood character will be conserved and protected in order to preserve the cultural and economic diversity of our neighborhoods:

The proposed project will strengthen neighborhood character by respecting the character-defining features of the KMMS Conservation District in conformance with the Secretary of the Interior's Standards.

- C) The City's supply of affordable housing will be preserved and enhanced:

The proposed project will have no adverse effect on the City's supply of affordable housing.

- D) The commuter traffic will not impede MUNI transit service or overburden our streets or neighborhood parking:

The proposed project will not result in commuter traffic impeding MUNI transit service or overburdening the streets or neighborhood parking.

- E) A diverse economic base will be maintained by protecting our industrial and service sectors from displacement due to commercial office development. And future opportunities for resident employment and ownership in these sectors will be enhanced:

The proposed project would allow the existing establishment to resume its original operations which will allow the hotel to retain and expand their current hotel staff.

- F) The City will achieve the greatest possible preparedness to protect against injury and loss of life in an earthquake.

Preparedness against injury and loss of life in an earthquake is unaffected by the proposed project. Any construction or alteration associated would be executed in compliance with all applicable construction and safety measures.

- G) That landmark and historic buildings will be preserved:

The proposed project in conformance with Appendix E of Article 11 of the Planning Code and the Secretary of the Interior's Standards.

- H) Parks and open space and their access to sunlight and vistas will be protected from development:

The proposed Permit to Alter will not impact the City's parks and open space.

4. For these reasons, the proposal overall, meets the provisions of Article 11 of the Planning Code regarding Major Alterations to Category I (Significant) buildings.

DECISION

That based upon the Record, the submissions by the Applicant, the staff of the Department and other interested parties, the oral testimony presented to this Commission at the public hearings, and all other written materials submitted by all parties, the Commission hereby **GRANTS WITH CONDITIONS Permit to Alter Application 2010.0964H** attached hereto as "EXHIBIT A" which is incorporated herein by reference as though fully set forth.

APPEAL AND EFFECTIVE DATE OF MOTION: The Commission's decision on a Certificate of Appropriateness shall be final unless appealed within thirty (30) days. Any appeal shall be made to the Board of Appeals, unless the proposed project requires Board of Supervisors approval or is appealed to the Board of Supervisors as a conditional use, in which case any appeal shall be made to the Board of Supervisors (see Charter Section 4.135).

THIS IS NOT A PERMIT TO COMMENCE ANY WORK OR CHANGE OF OCCUPANCY UNLESS NO BUILDING PERMIT IS REQUIRED. PERMITS FROM THE DEPARTMENT OF BUILDING INSPECTION (and any other appropriate agencies) MUST BE SECURED BEFORE WORK IS STARTED OR OCCUPANCY IS CHANGED.

I hereby certify that the Historical Preservation Commission ADOPTED the foregoing Motion on November 3, 2010.

Linda D. Avery
Commission Secretary

AYES:

NAYS:

ABSENT:

ADOPTED: November 3, 2010

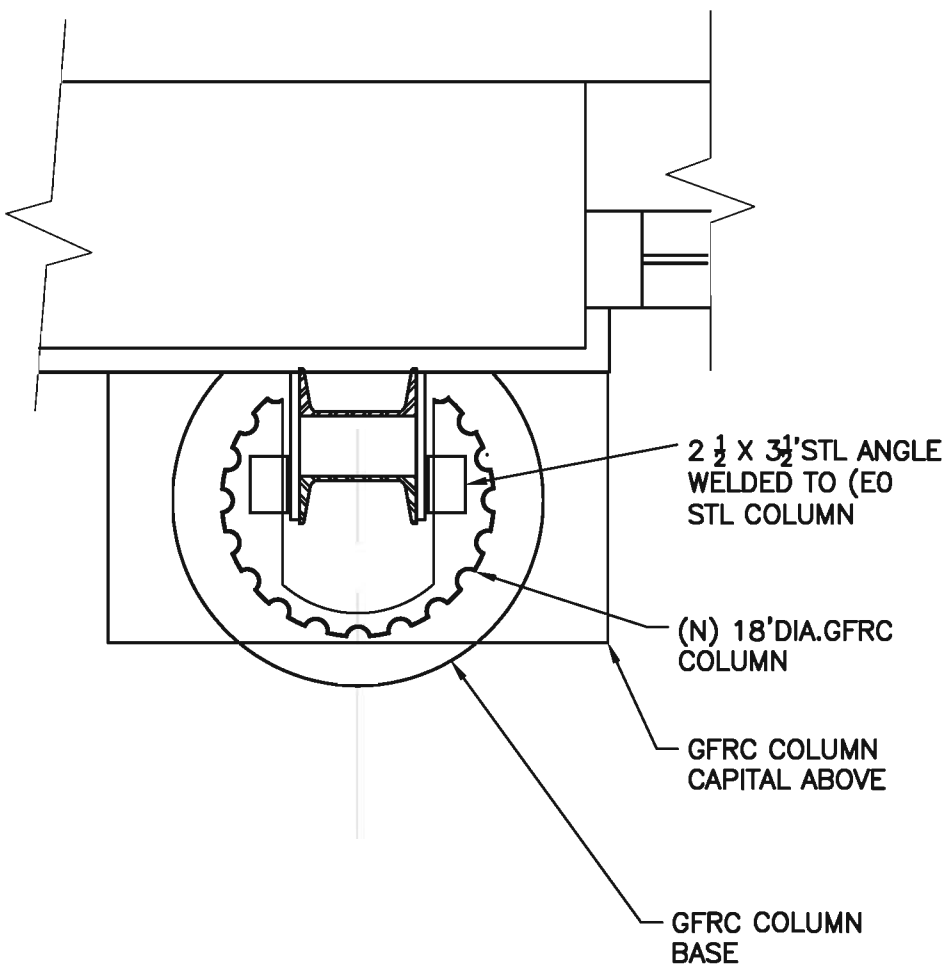
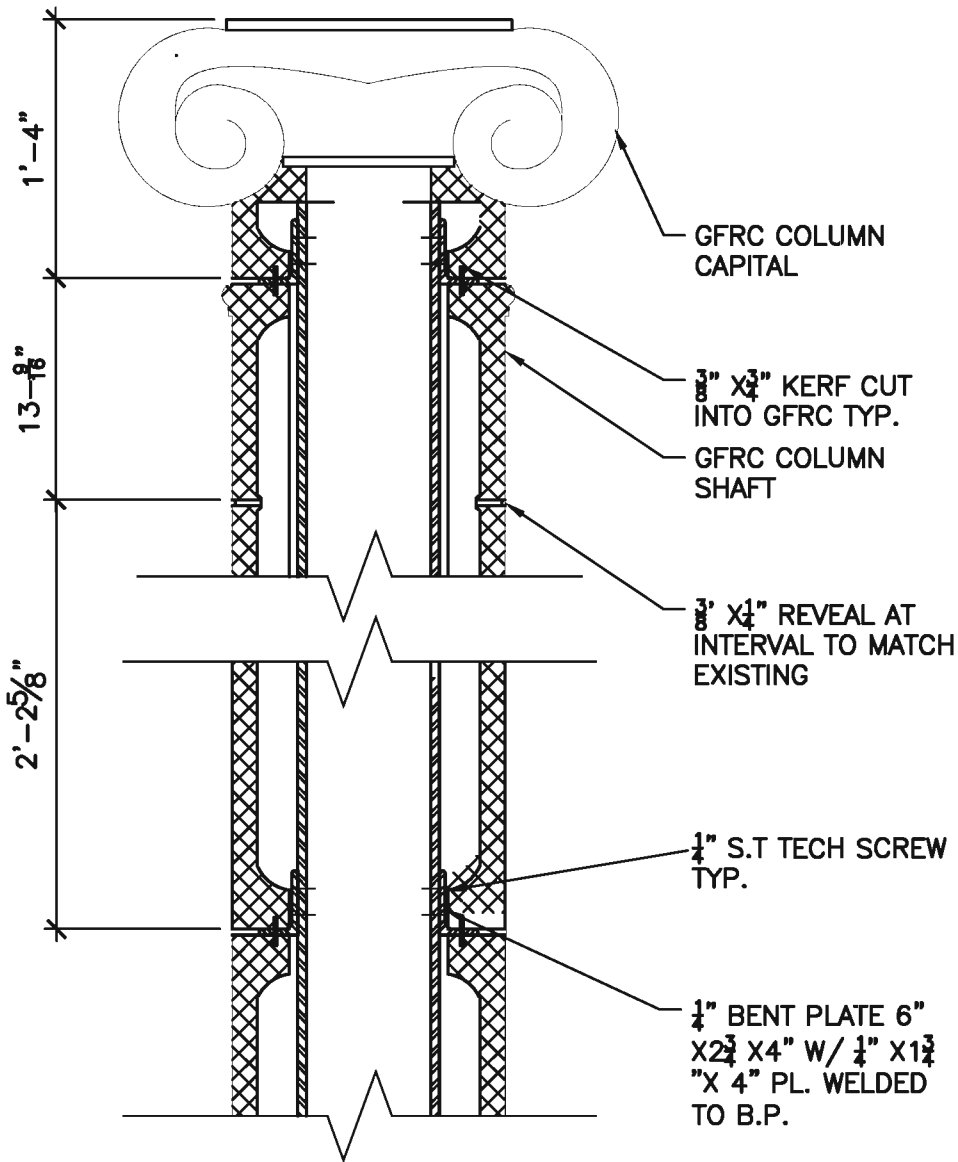

2 GFRc COULUMN ATTACHMENT
A1.1 1" = 1'-0"

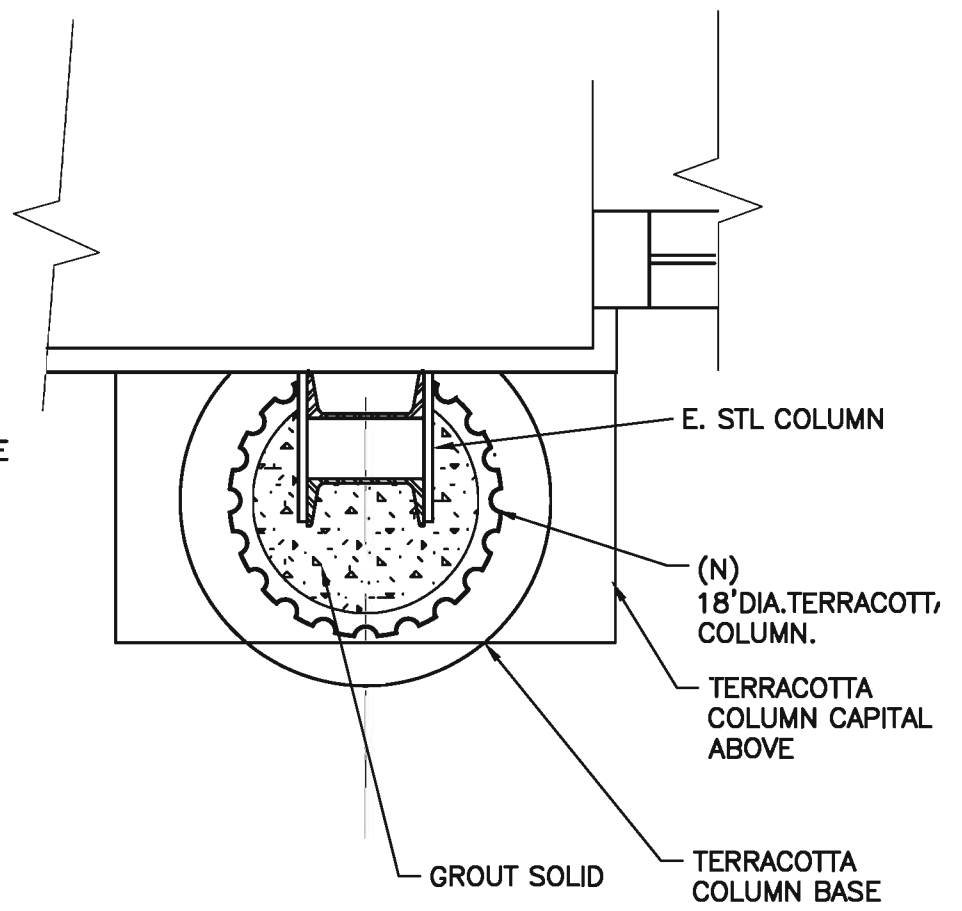

1 TERRACOTTA COLUMN SECTION
A1.1 1" = 1'-0"

Tom Lewis Restoration and Consulting (TLRC)
768 Brannan St.
San Francisco CA 94103
t. (415) 734-9030
f. (415) 734-9035
tom@lewisrestoration.com

211 SUTTER ST SAN FRANCISCO CA TERRACOTTA REPLACEMENT	Job	Sheet
	Date 5-19-2010	
	REV. 5---2010	
		of

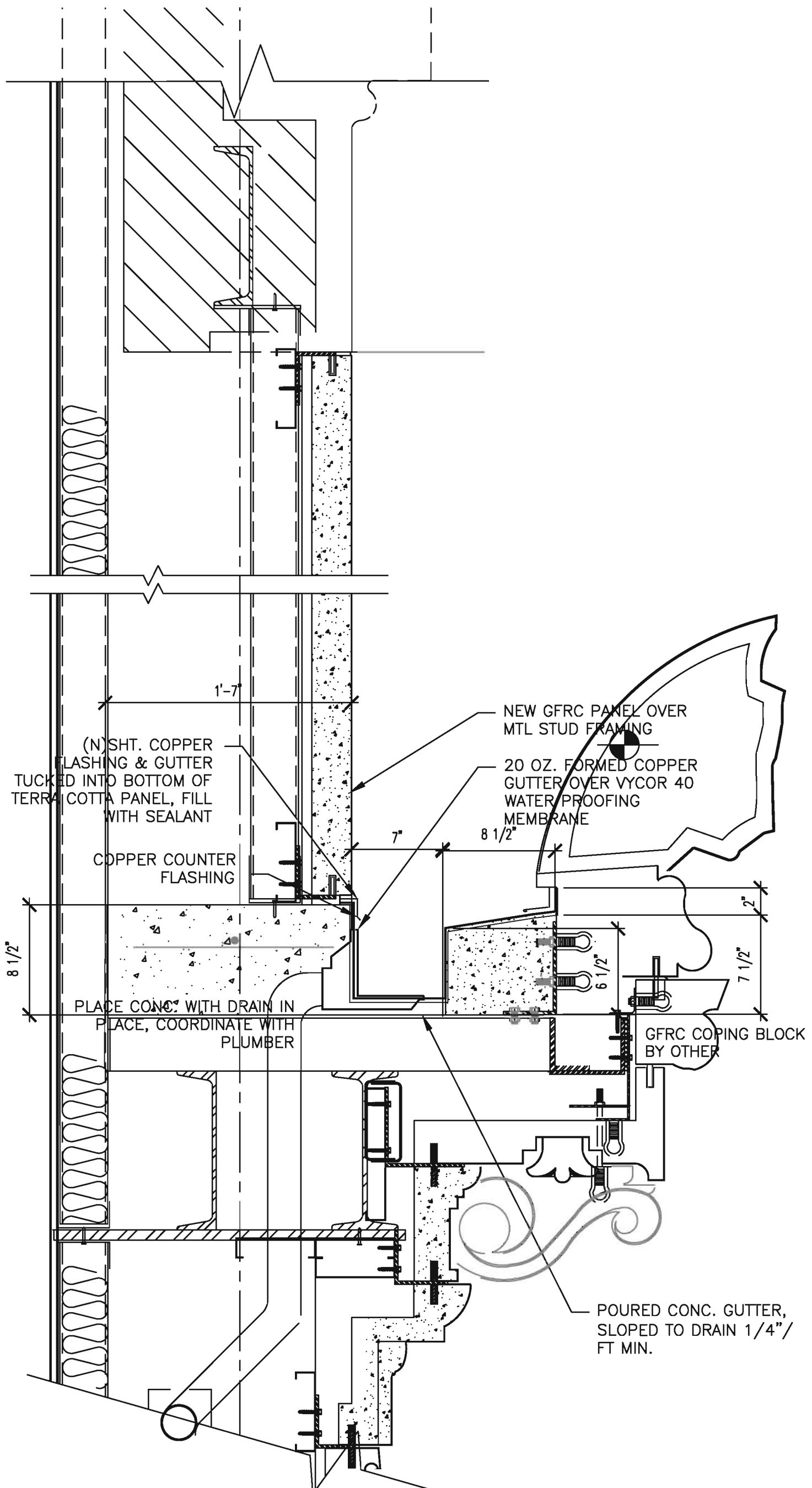

6 GUTTER & FLASHING AT WALL
 A1.1 1-1/2" = 1'-0"

Tom Lewis Restoration and Consulting (TLRC)
 768 Brannan St.
 San Francisco CA 94103
 t. (415) 734-9030
 f. (415) 734-9035
 tom@lewisrestoration.com

211 SUTTER ST SAN FRANCISCO CA TERRACOTTA REPLACEMENT	Job	Sheet
	Date 10-19-2010	
	REV. 10-19-2010	of

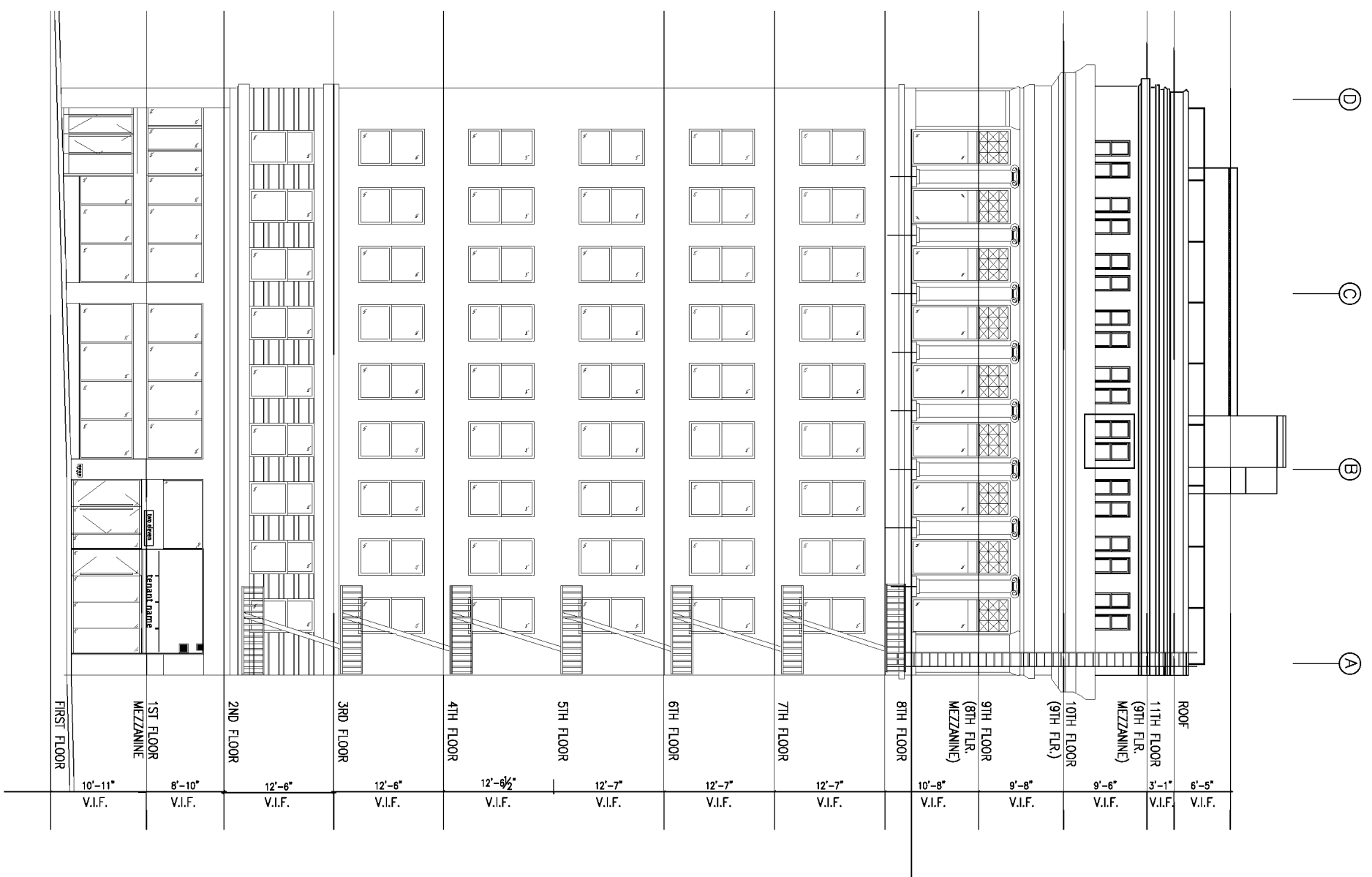
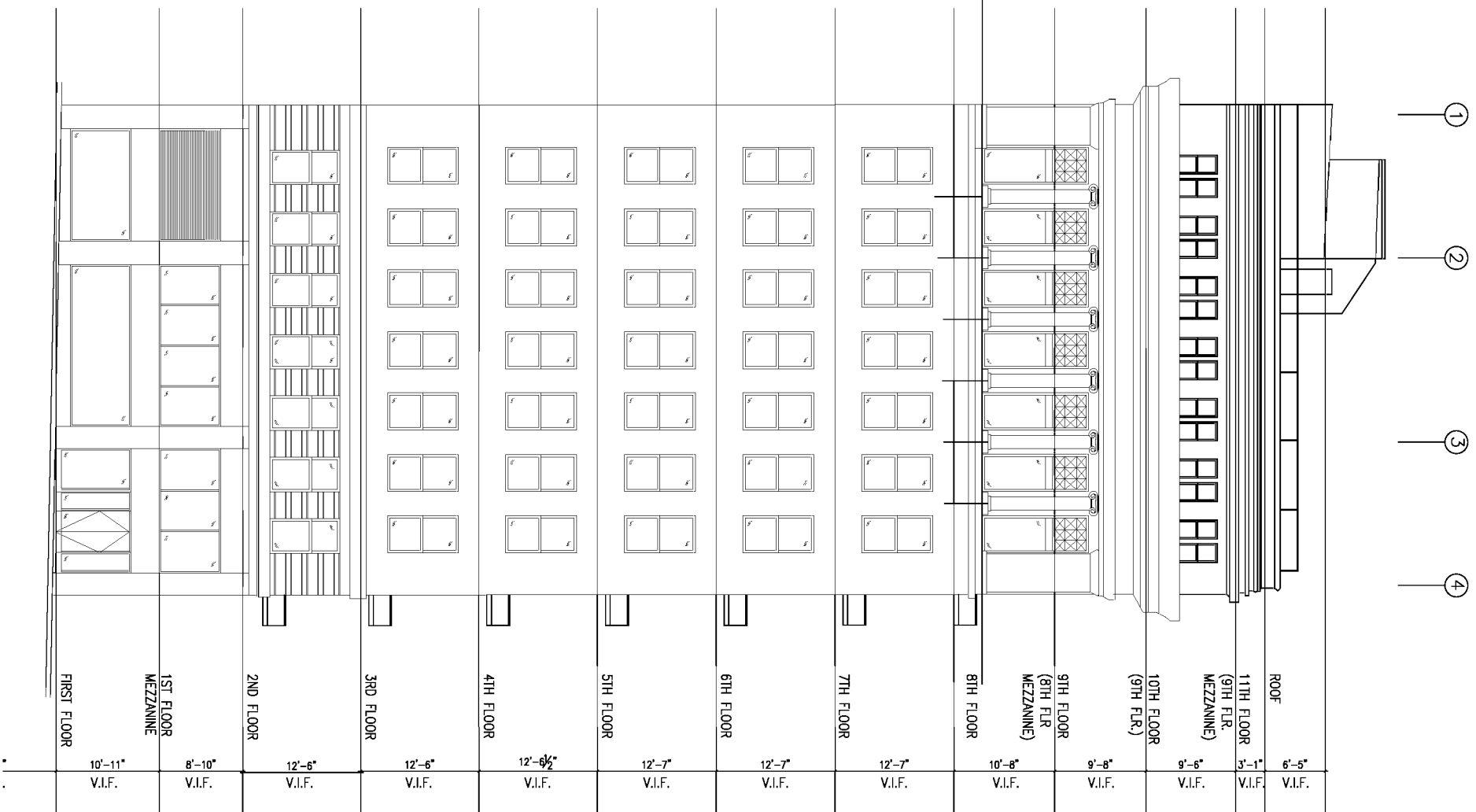

Tom Lewis Restoration and Consulting (TLRC)
 768 Brannan St.
 San Francisco CA 94103
 t. (415) 734-8030
 f. (415) 734-8035
 tom@lewisrestoration.com

211 SUTTER ST
 SAN FRANCISCO CA
 TERRACOTTA REPLACEMENT

DATE	10-19-2010
REV.	10-19-2010
BY	
CHKD	

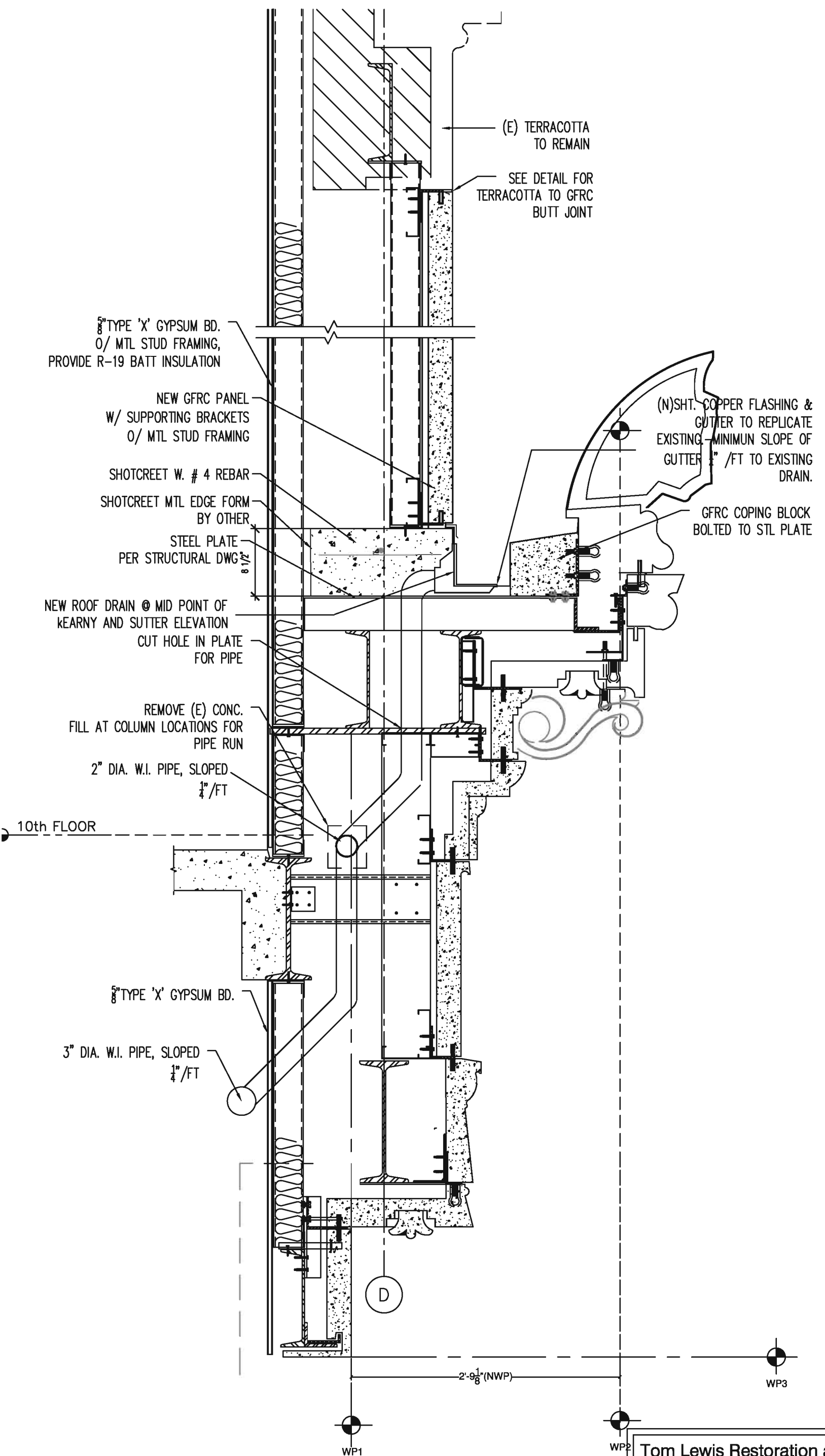

1 GFRC WALL SECTION—KEARNY ST.
A1.1 WALL SECTION BETWEEN WINDOWS
SIMILAR AT SUTTER ST. 1" = 1'-0"

Tom Lewis Restoration and Consulting (TLRC)
 768 Brannan St.
 San Francisco CA 94103
 t. (415) 734-9030
 f. (415) 734-9035
 tom@lewisrestoration.com

211 SUTTER ST SAN FRANCISCO CA TERRACOTTA REPLACEMENT	Job	Sheet
	Date 10-19-2010	
	REV. 10-19-2010	

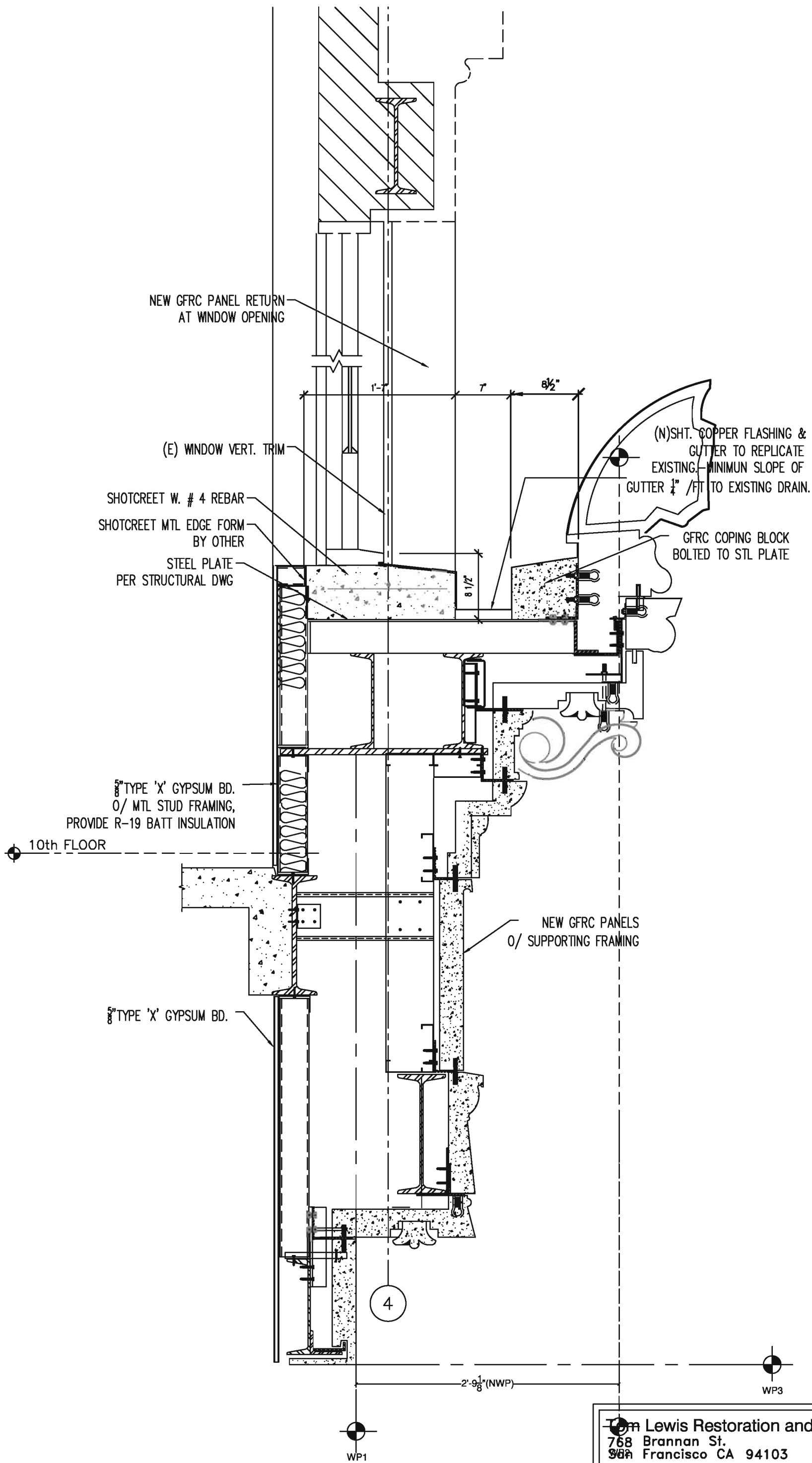

1 GFRC, GUTTER DETAIL-SUTTER ST.
 A1.1 WINDOW/GUTTER SECTION SIMILAR AT KEARNY ST
 1" = 1'-0"

Tom Lewis Restoration and Consulting (TLRC)
 768 Brannan St.
 San Francisco CA 94103
 t. (415) 734-9030
 f. (415) 734-9035
 tom@lewisrestoration.com

211 SUTTER ST SAN FRANCISCO CA	Job	Sheet
TERRACOTTA REPLACEMENT	Date 10-19-2010	
	REV. 10-19-2010	
		or

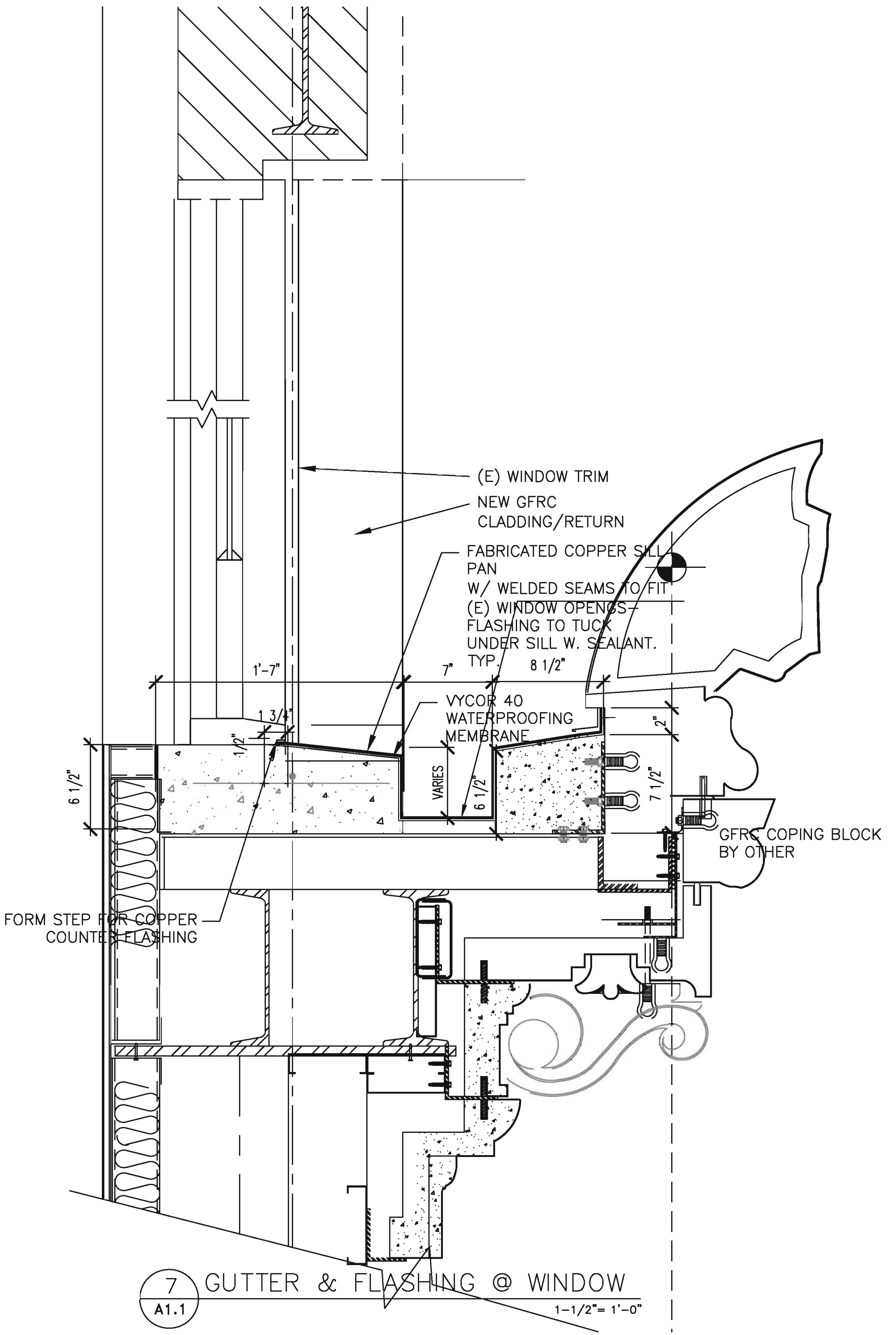

Tom Lewis Restoration and Consulting (TLRC)
 768 Brannan St.
 San Francisco CA 94103
 t. (415) 734-9030
 f. (415) 734-9035
 tom@lewisrestoration.com

211 SUTTER ST SAN FRANCISCO CA TERRACOTTA REPLACEMENT	Job	Sheet
	Date 10-19-2010	
	REV. 10-19-2010	of

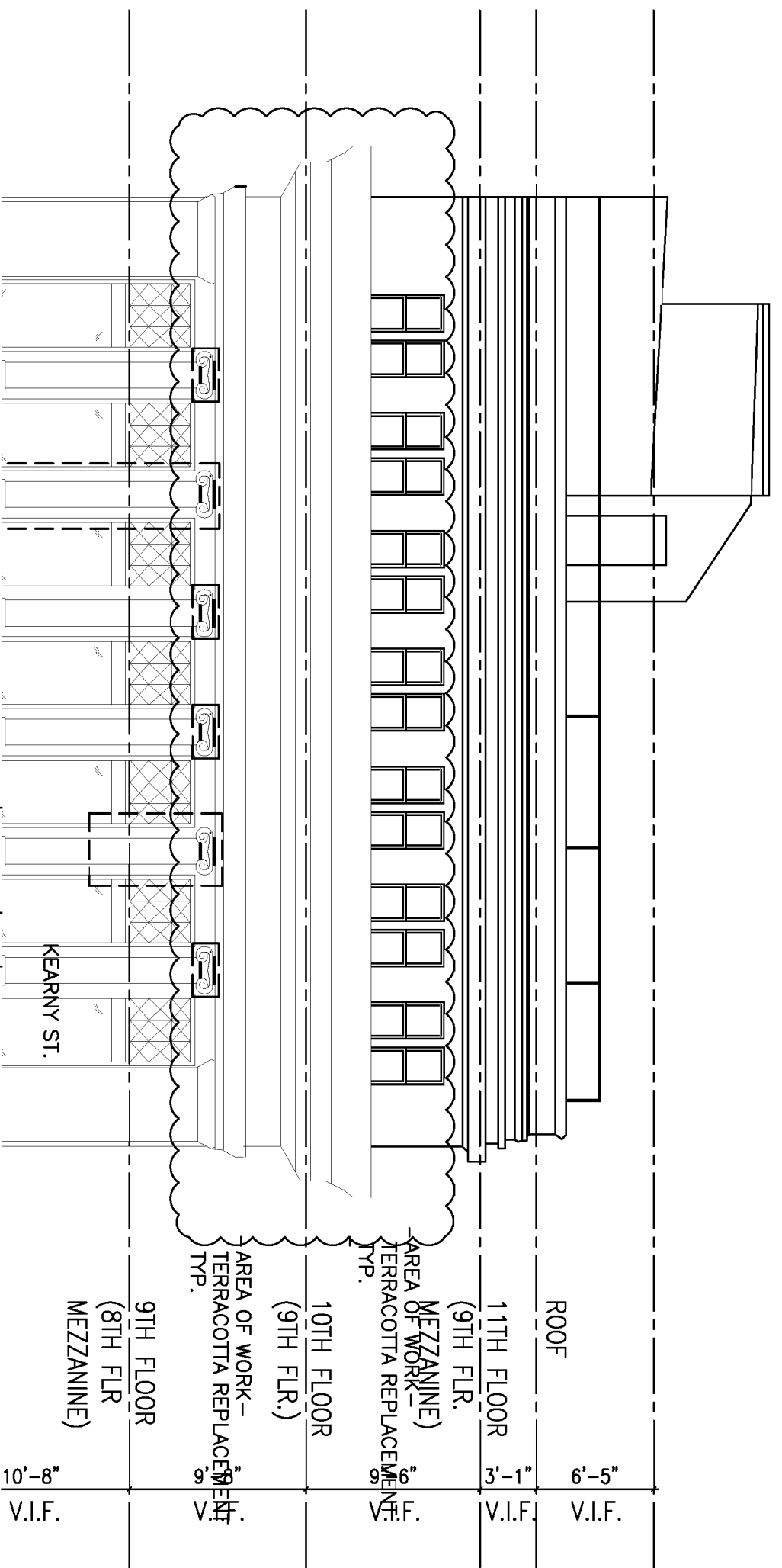

ROOF 6'-5" V.I.F.

11TH FLOOR 3'-1" V.I.F.

(9TH FLR. MEZZANINE) AREA OF WORK - TERRACOTTA REPLACEMENT TYP. 6" V.I.F.

10TH FLOOR (9TH FLR.) AREA OF WORK - TERRACOTTA REPLACEMENT TYP. 9" V.I.F.

9TH FLOOR (8TH FLR MEZZANINE) 10'-8" V.I.F.

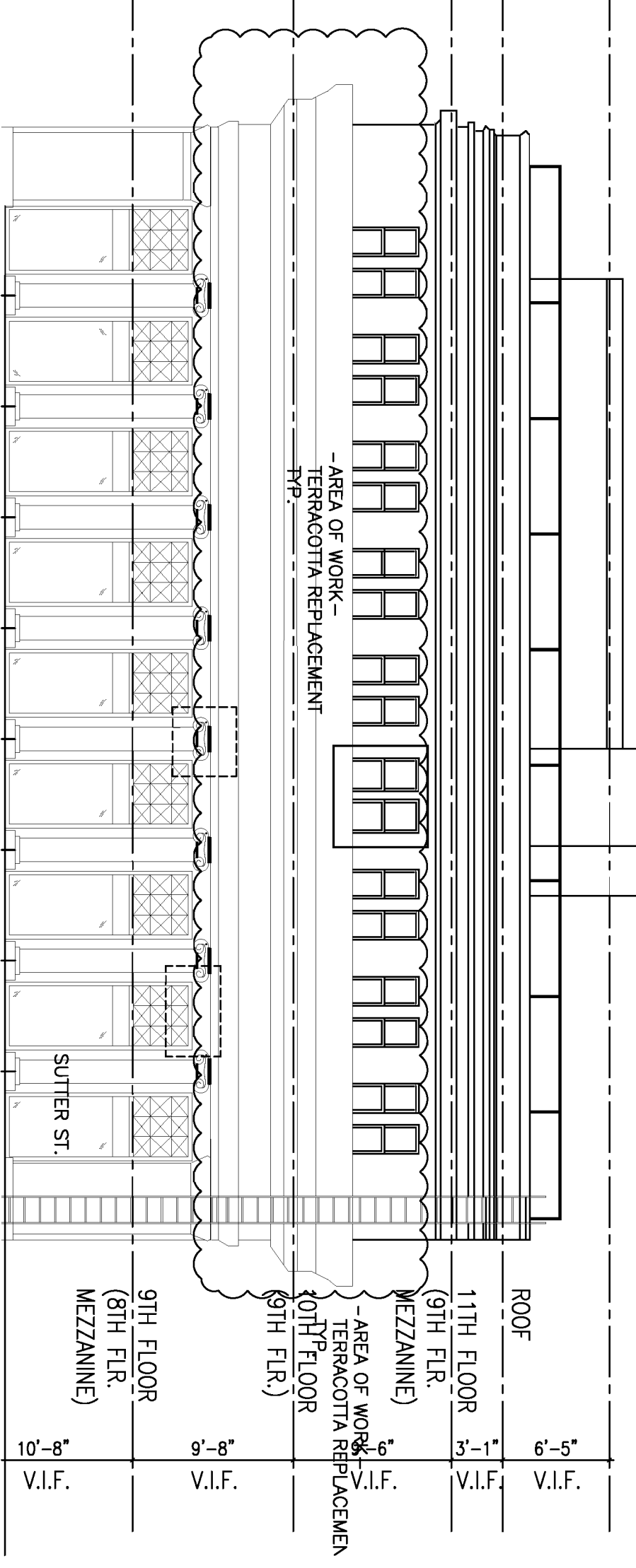

ROOF 6'-5" V.I.F.

11TH FLOOR 3'-1" V.I.F.

(9TH FLR. MEZZANINE) AREA OF WORK - TERRACOTTA REPLACEMENT TYP. 6" V.I.F.

10TH FLOOR (9TH FLR.) AREA OF WORK - TERRACOTTA REPLACEMENT TYP. 9" V.I.F.

9TH FLOOR (8TH FLR. MEZZANINE) 10'-8" V.I.F.

Tom Lewis Restoration and Consulting (TLRC) 768 Brannan St. San Francisco CA 94103 t. (415) 734-9039 f. (415) 734-9035 tom@lewisrestoration.com										
211 SUTTER ST SAN FRANCISCO CA TERRACOTTA REPLACEMENT	<table border="1"> <tr> <th>DATE</th> <th>BY</th> <th>REVISION</th> </tr> <tr> <td>10-18-2018</td> <td></td> <td>REV.</td> </tr> <tr> <td>10-18-2019</td> <td></td> <td></td> </tr> </table>	DATE	BY	REVISION	10-18-2018		REV.	10-18-2019		
DATE	BY	REVISION								
10-18-2018		REV.								
10-18-2019										

SAW CUT AROUND SPA
AS RECTANGULAR AS
SUBSTRATE ADDITIONALLED AREA OR HOLE
OR TO SOUND BASE. POSSIBLE. CUT
UP TO 1/2"

1. THIN SECTION GLAZE SPALL AND SURFACE
PROFILING OF DEEP REPAIR— EDISON COATING
INC. 'THIN FILL 55'

2. DEEP REPAIR— EDISON 'CUSTOM SYSTEM 45'

3. CRACK REPAIR— EDISON 'FLEXIWELD 530' FOR
CRACKS 1/32—1/8' DEEP

4. GLAZE REPLACEMENT— EDISON 'AQUATHANE
UA-210E
CLEAR: UA210E w/ TYPE G BONDING ADDITIVE
PIGMENTED: UA210E w/ PRIMER #240

PREPARE SURFACE BY CHIPPING
FLUSH OUT AREA WITH AIR OR
VACUUM

EW STAINLESS STEEL PINS 1/4"Ø
6" O.C. MAX. WHEN "D" EXCEEDS
" (STONE/PRECAST ONLY). DRILL
" DIAM. HOLE, INSTALL S.S. PINS
N JAHN M80 ANCHOR GROUT.

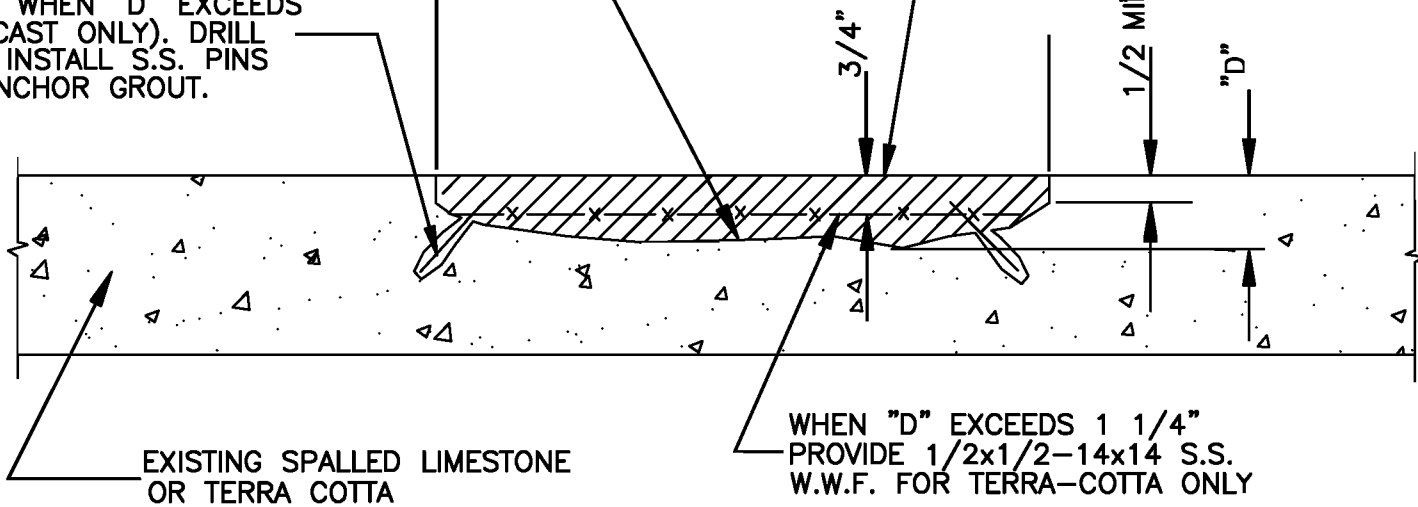

EXISTING SPALLED LIMESTONE
OR TERRA COTTA

WHEN "D" EXCEEDS 1 1/4"
PROVIDE 1/2x1/2-14x14 S.S.
W.W.F. FOR TERRA-COTTA ONLY

SPALL REPAIR METHOD FOR TERRA COTTA AND/OR STON DETAIL

NOT TO SCA

NOTES:

- 1) REPAIRS TO MATCH EXISTING TERRA-COTTA OR STONE IN COLOR, SHAPE AND TEXTURE.
- 2) APPLY THE MORTAR MIX USING A TROWELL TO A MAXIMUM THICKNESS OF 3".
- 3) BUILD UP PATCHING MATERIAL SLIGHTLY ABOVE ADJACENT MASONRY SURFACE.
- 4) FOLLOW MANUFACTURFR'S INSTRUCTIONS AND RFCOMMFNDATIONS.

Tom Lewis Restoration and Consulting (TLRC)
768 Brannan St.
San Francisco CA 94103
t. (415) 734-9030
f. (415) 734-9035
tom@lewisrestoration.com

211 SUTTER ST
SAN FRANCISCO CA
TERRACOTTA REPLACEMENT

Job	Sheet
Date 5-19-2010	
REV. 5---2010	
	of

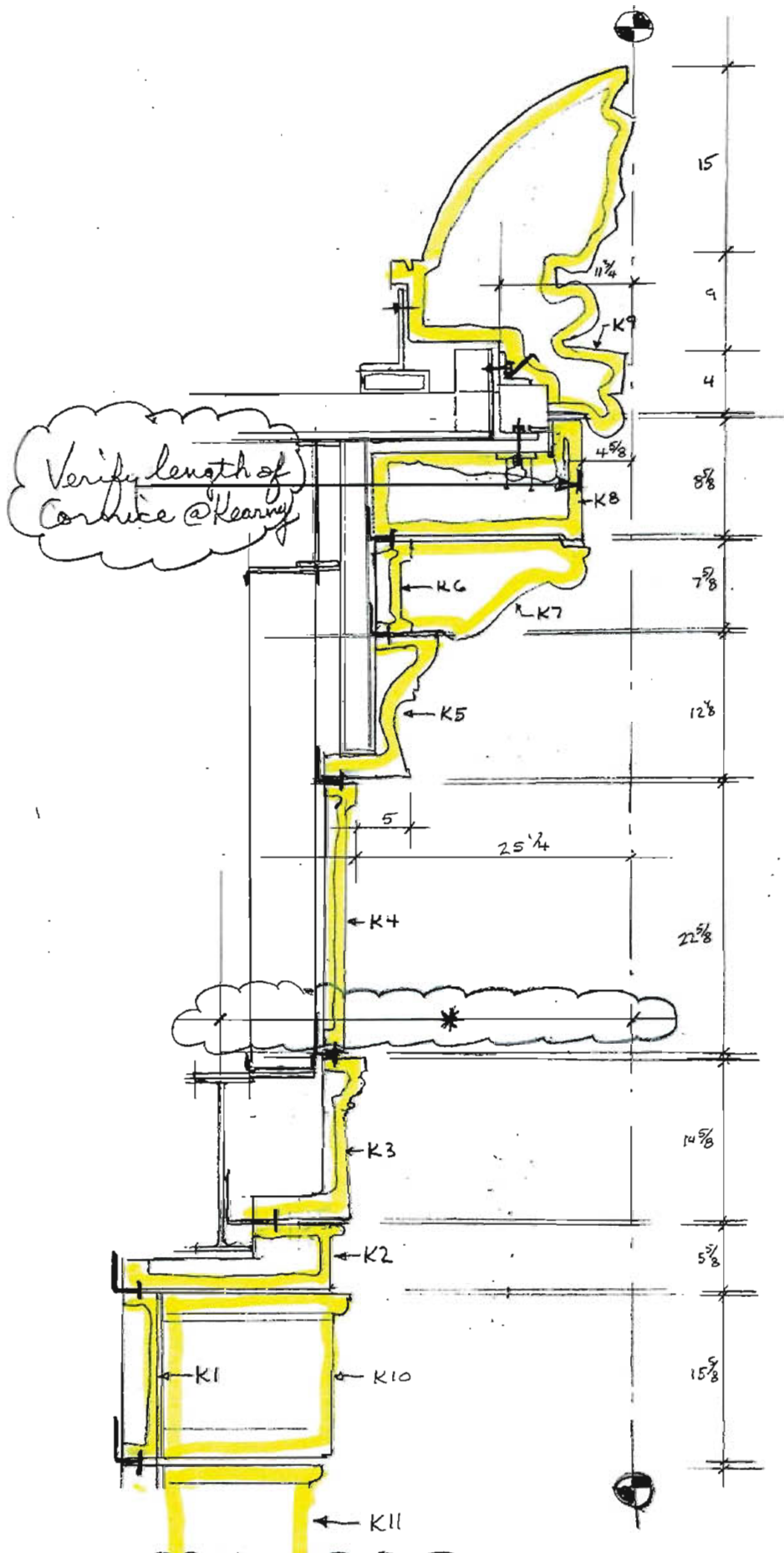

Verify length of Corbice @ Kearny

* Dimension to (E) steel frame varies 4" - line D1 to D4 Kearny Elev.

Architectural Facades
 600 E Luchessa Ave
 Gilroy, CA 95020
 211 Sutter

5/12/10
 SKI

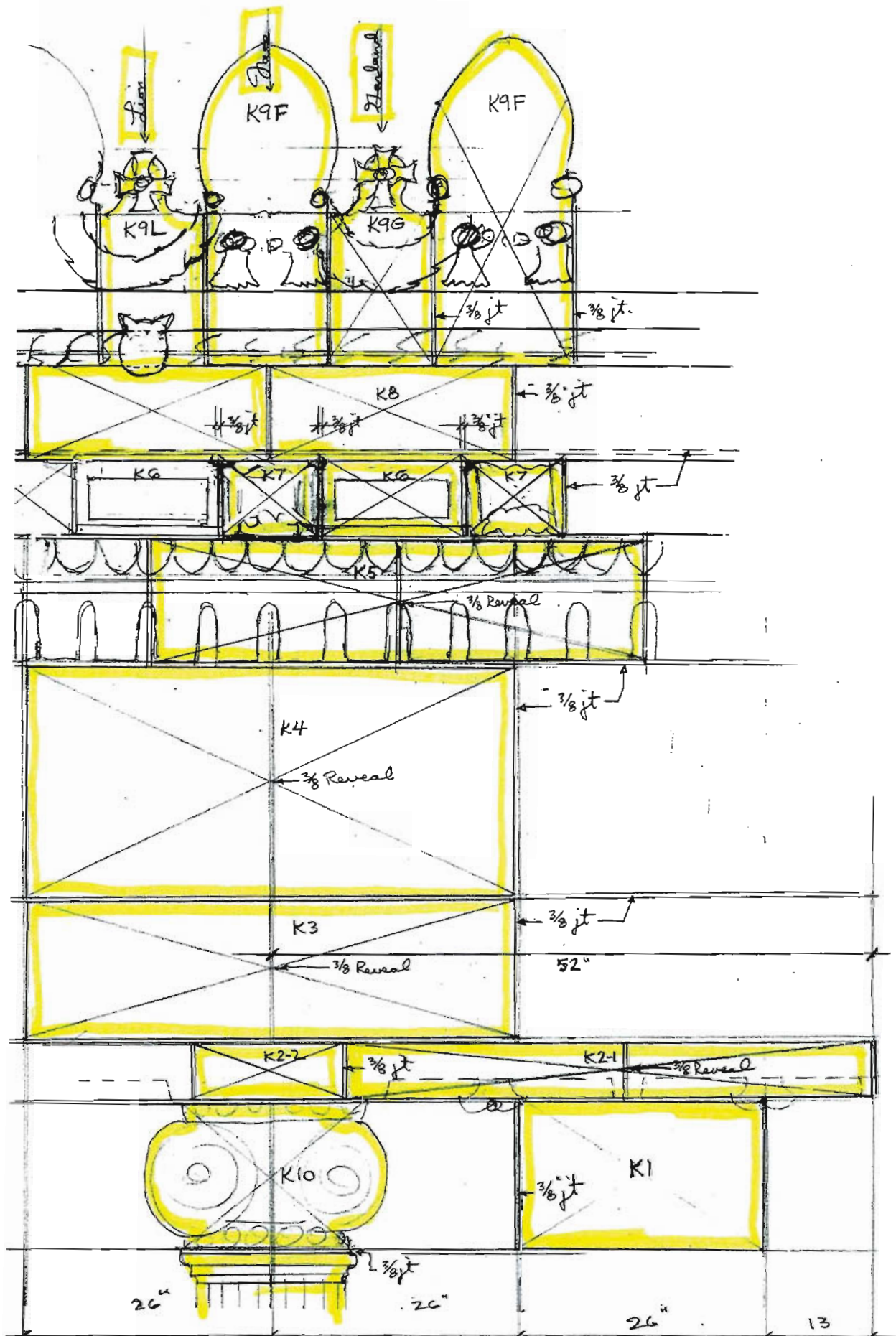

(3)

211 Sutter

Architectural Facades
600 E Luchessa Ave
Gilroy, CA 95020

5/12/10
SK2



④

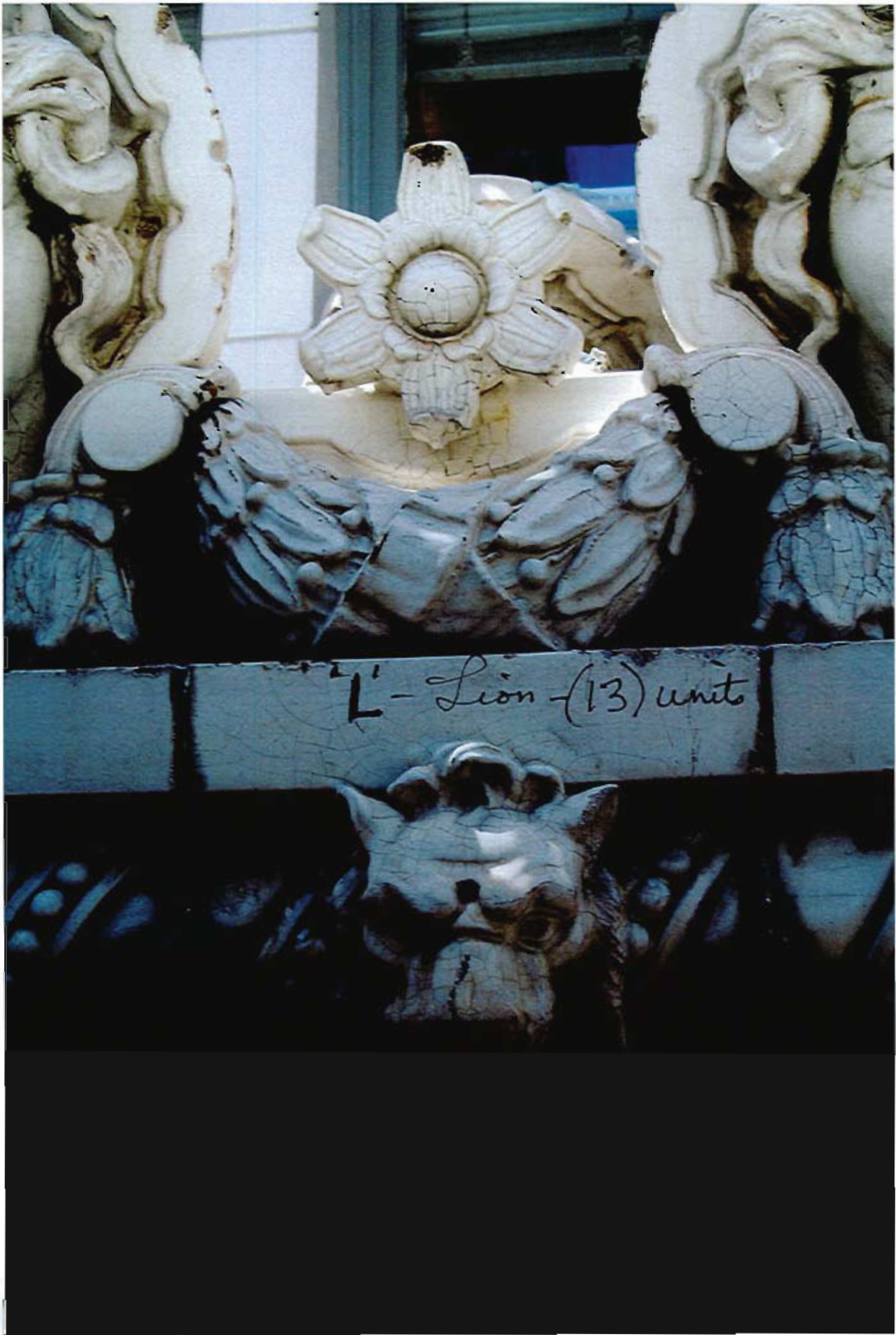

101



6



7

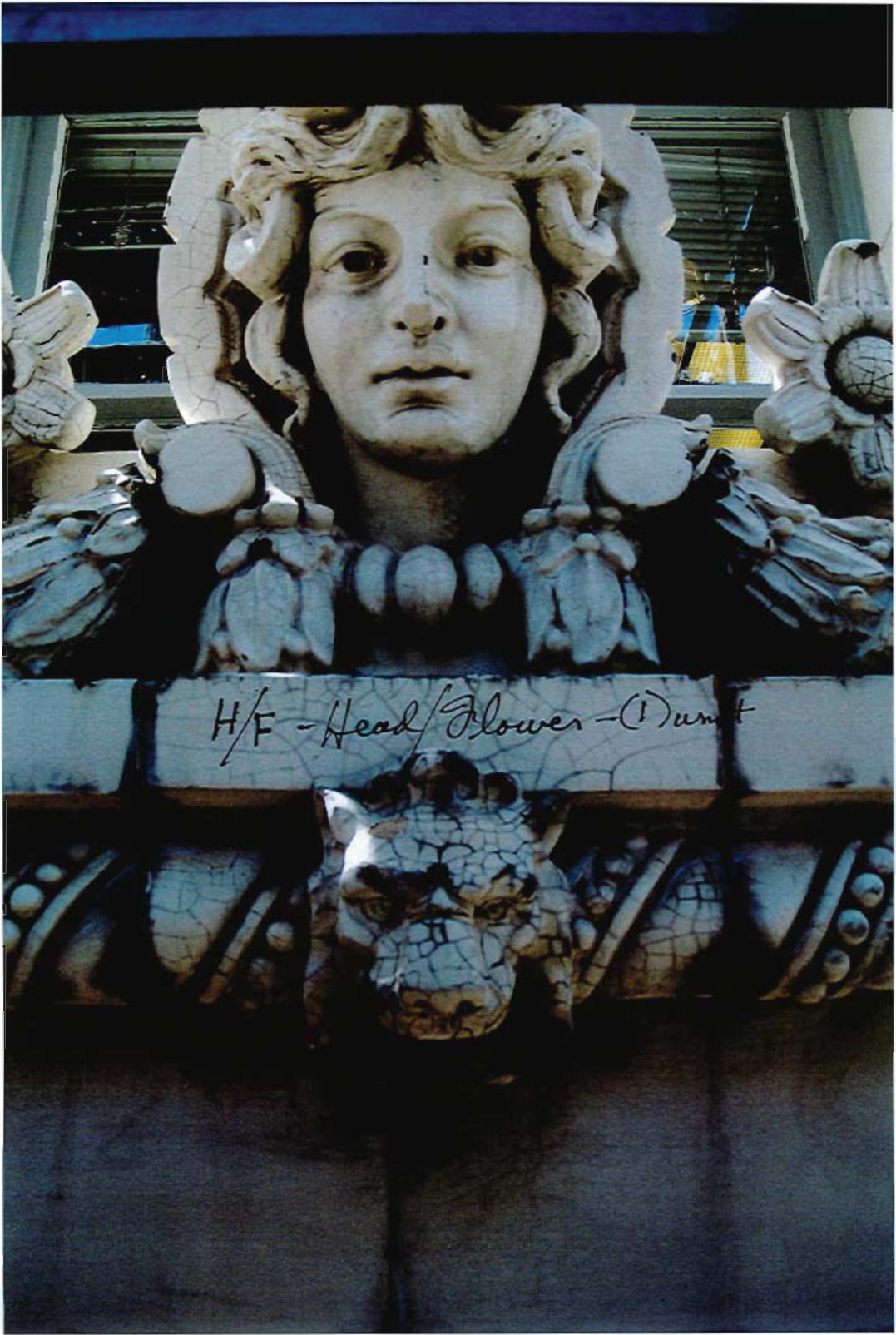

H/F - Head/Flower - (1) unit

8

Architectural Facades Unlimited, Inc.

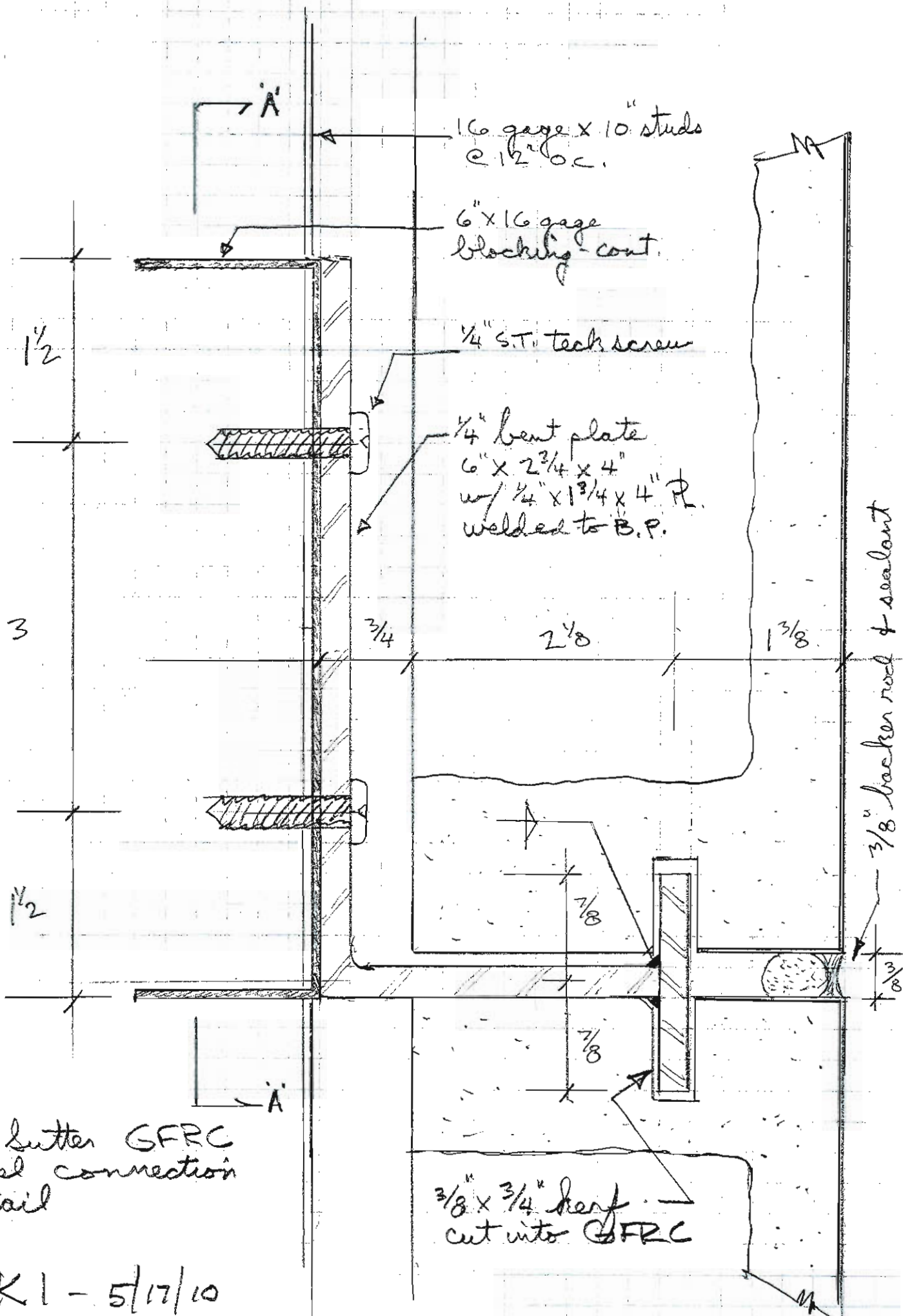

211 gutter GFRP panel connection detail

SK1 - 5/17/10

Architectural Facades Unlimited, Inc.

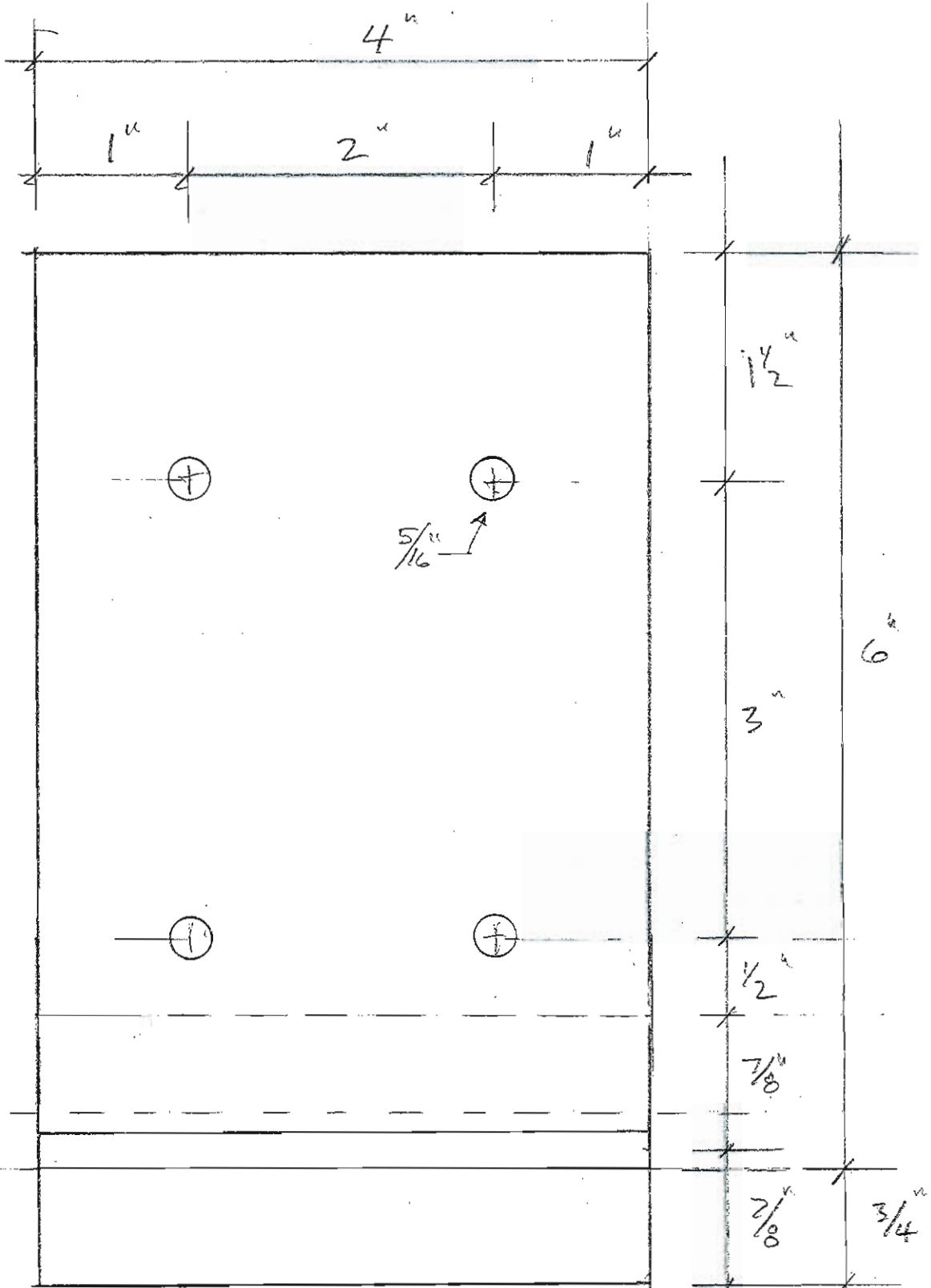

Section 'A'A'

211 Letter GFRC panel Connection

5/17/10 SK 2

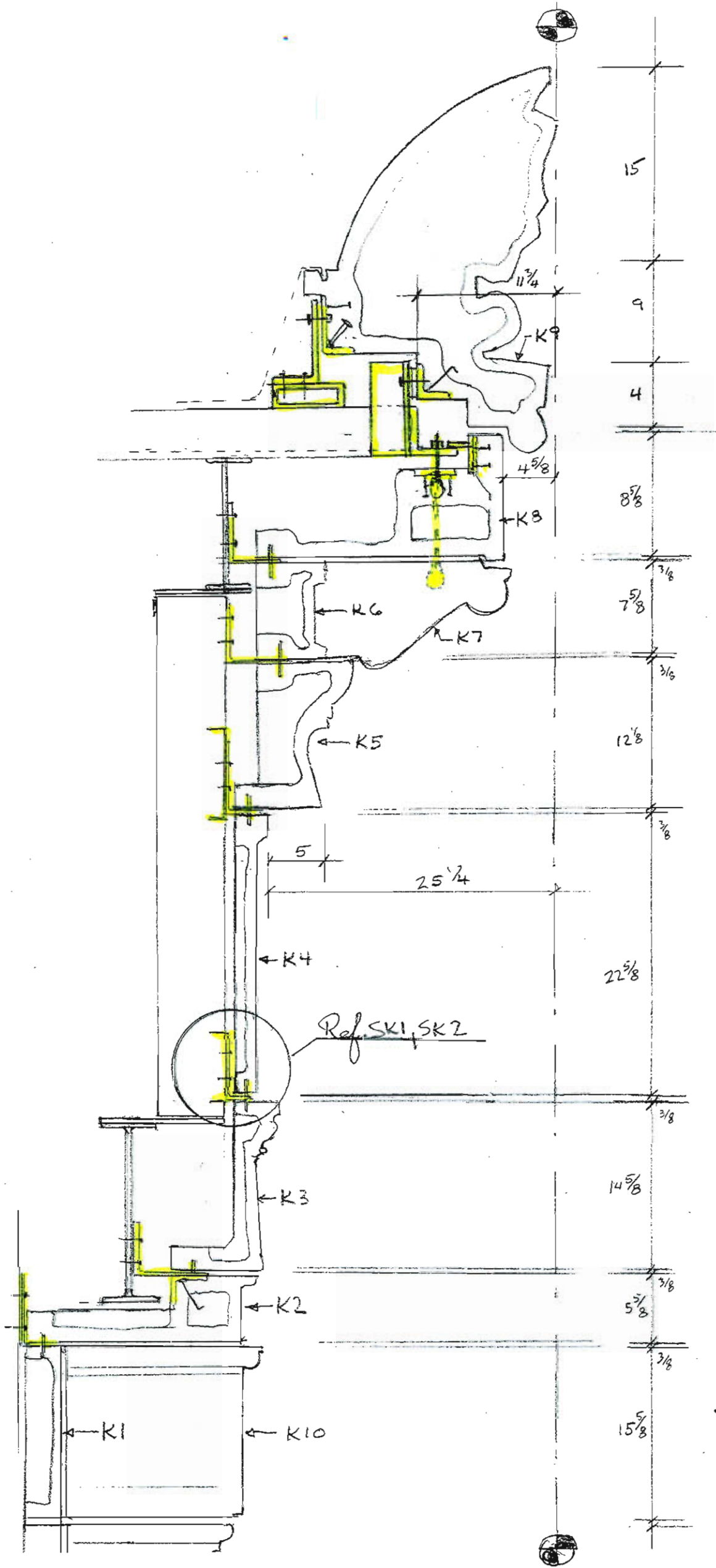

Architectural Facades
 600 E Luchessa Ave
 Gilroy, CA 95020

5/17/10
 SK3

GFRC test Report



APPLIED MATERIALS & ENGINEERING, INC.

980 41st Street
Oakland, CA 94608

Tel: (510) 420-8190
FAX: (510) 420-8186
e-mail: info@appmateng.com

FLEXURAL STRENGTH OF GLASS FIBER REINFORCED CONCRETE

Project Number:	110043C	Report Date:	03/30/10
Project Name:	Quality Control Testing	Type of Sample:	GFRC- Sprayed
		Test Method:	ASTM C 947
		Date Cast:	02/26/10
Client Name:	Architectural Facades Unlimited, Inc.	Date Tested:	03/30/10
		Age, Days:	32
		Date Received:	03/08/10

Test Conditions and Results

Sample ID:	28-Day	Bulk Density, pcf:	..	ASTM C 948
Glass Content, %:	5.2	Absorption, %:	..	ASTM C 948
Sample Conditioning:	Wet	Elastic Modulus, psi:	..	PCI MNL -130
Test Span, in.:	10			
Crosshead Speed, in./min:	0.2			

Laboratory Test Results

SAMPLE NUMBER	WIDTH (in.)	DEPTH (in.)	FLEXURAL LOAD		FLEXURAL STRENGTH		REMARKS
			YIELD LOAD (lbf)	ULTIMATE LOAD (lbf)	YIELD STRENGTH (psi)	ULTIMATE STRENGTH (psi)	
1	2.03	0.488	68	153	1407	3165	None
2	2.00	0.493	78	155	1605	3189	None
3	2.05	0.483	72	156	1506	3262	None
4	2.01	0.489	72	164	1498	3412	None
5	2.01	0.506	74	171	1438	3323	None
6	2.05	0.506	80	174	1524	3315	None
Average					1496	3278	

Tested samples will be discarded two business days from the report date.

Remarks:

Cc: Frank Bracken: frank.bracken@architecturalfacades.com
Nelly Kaleva: nelly.kaleva@architecturalfacades.com

Reviewed by

Mohammed Faiyaz

Mohammed Faiyaz
Laboratory Manager



ACCREDITED
ASTM C 947 Only

Specification

Architectural Facades Unlimited, Inc.

SECTION 03490

GLASS-FIBER REINFORCED PRECAST CONCRETE

PART 1 GENERAL

1.1 SECTION INCLUDES

- A. Plant-cast, glass-fiber-reinforced precast concrete panels.
- B. Embedded hardware and anchors.
- C. Loose connection hardware.
- D. Integrated steel support framing.

1.2 RELATED SECTIONS

- A. Section 03300 - Cast-in-Place Concrete: Building structural frame.
- B. Section 04800 - Unit Masonry: Back-up masonry.
- C. Section 05120 - Structural Steel: Building structural frame.
- D. Section 05400 - Cold-Formed Metal Framing: Structural stud members.
- E. Section 07190 - Water Repellent Coating.
- F. Section 07600 - Metal flashings.
- G. Section 07840 - Firestopping: Fire barrier seal between units and edge of floor slab.
- H. Section 07900 - Joint Sealers: Application of backer rods or bond breakers and joint sealers.

1.3 REFERENCES

- A. ASTM A 27/A 27M - Standard Specification for Steel Castings, Carbon for General Application.
- B. ASTM A 36/A 36M - Standard Specification for Carbon Structural Steel.
- C. ASTM A 47/A 47M - Standard Specification for Ferritic Malleable Iron Castings.
- D. ASTM A 123/A 123M - Standard Specification for Zinc (Hot-Dip) on Iron and Steel Hardware.

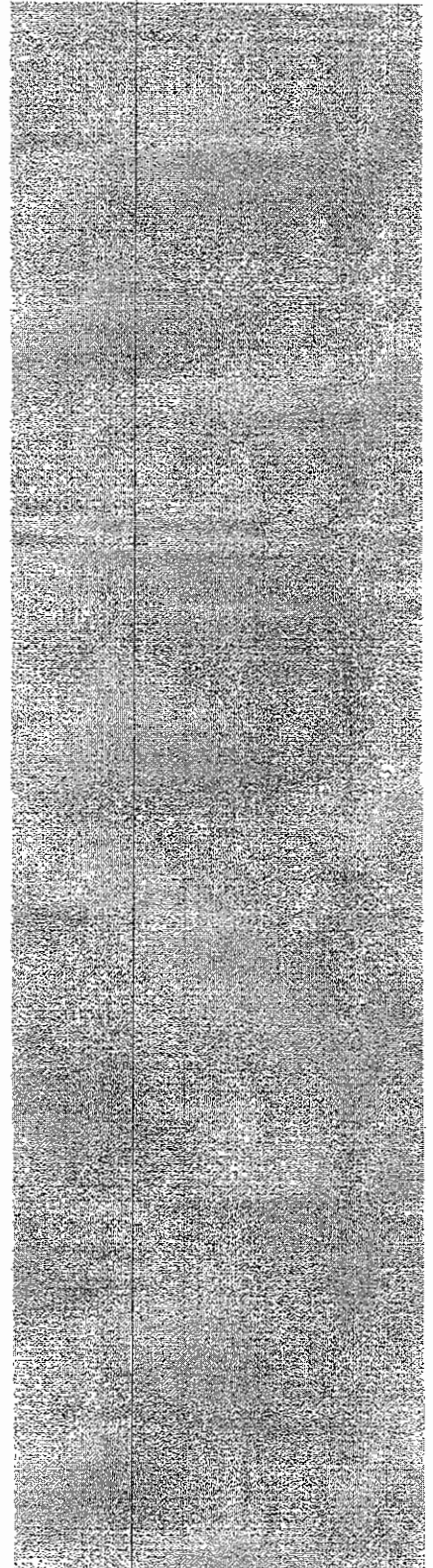

- E. ASTM A 108 – Standard Specification for Steel Bars, Carbon, Cold-Finished, Standard Quality.
- F. ASTM A 153/A 153M - Standard Specification for Zinc Coating (Hot-Dip Galvanized) Coatings on Iron and Steel Products.
- G. ASTM A 283/A 283M - Standard Specification for Low and Intermediate Tensile Strength Carbon Steel Plates.
- H. ASTM A 325 - Standard Specification for Structural Bolts, Steel, Heat Treated, 120/105 ksi Minimum Tensile Strength.
- I. ASTM A 500 - Standard Specification for Cold-Formed Welded and Seamless Carbon Steel Structural Tubing in Rounds and Shapes.
- J. ASTM A 513 - Standard Specification for Electric-Resistance-Welded Carbon and Alloy Steel Mechanical Tubing
- K. ASTM A 653/A 653M - Standard Specification for Steel Sheet, Zinc-Coated (Galvanized) or Zinc-Iron Alloy-Coated (Galvannealed) by the Hot-Dip Process.
- L. ASTM A780 - Standard Practice for Repair of Damaged and Uncoated Areas of Hot-Dip Galvanized Coatings.
- M. ASTM A1003/A1003M - Standard Specification for Steel Sheet, Carbon, Metallic- and Nonmetallic-Coated for Cold-Formed Framing Members.
- N. ASTM A1008/A1008M - Standard Specification for Steel, Sheet, Cold-Rolled, Carbon, Structural, High-Strength Low-Alloy and High-Strength Low-Alloy with Improved Formability.
- O. ASTM C 33 - Standard Specification for Concrete Aggregates.
- P. ASTM C 150 - Standard Specification for Portland Cement.
- Q. ASTM C 260 - Standard Specification for Air-Entraining Admixtures for Concrete.
- R. ASTM C 494/C 494M - Standard Specification for Chemical Admixtures for Concrete.
- S. ASTM C 618 - Standard Specification for Coal Fly Ash and Raw or Calcined Natural Pozzolan for Use as a Mineral Admixture in Portland Cement Concrete.
- T. ASTM C 979 - Standard Specification for Pigments for Integrally Colored Concrete.
- U. ANSI - American Iron and Steel Institute (AISI), Specification for the Design of Cold-Formed Steel Structural Members
- V. AWS D1.1 - Structural Welding Code - Steel.
- W. AWS D1.3 - Structural Welding Code - Sheet Steel.
- X. AWS D1.4 - Structural Welding Code - Reinforcing Steel.
- Y. PCI MNL-117 – Manual for Quality Control for Plants and Production of Architectural Precast Concrete Products.

- Z. PCI MNL-128 – Recommended Practice for Glass Fiber Reinforced Concrete Panels.
- AA. PCI MNL-130 – Manual for Quality Control for Plants and Production of Glass Fiber Reinforced Concrete Products.
- BB. SSPC 2 – Hand Tool Cleaning.
- CC. SSPC 3 – Power Tool Cleaning.
- DD. SSPC Paint 20 - Zinc-Rich Primers (Type I - Inorganic and Type II - Organic).
- EE. SSPC Paint 25 - Zinc Oxide, Alkyd, Linseed Oil Primer for Use Over Hand Cleaned Steel, Type I and Type II
- FF. CIELAB - International Commission of Illumination, 1976 Standards.

1.4 SYSTEM DESCRIPTION

- A. System: Plant fabricated glass-fiber-reinforced precast concrete panels consisting of face mix, back-up mix, steel support frame attached via pins, gravity anchors and flex anchors, steel connections for panel attachment to structure, and other inclusions for attachments to panels.
- B. Design Requirements: Design glass-fiber-reinforced precast concrete panels and shapes under the supervision of a professional engineer and in accordance with procedures of PCI MNL-128, Recommended Practices for Glass Fiber Reinforced Concrete Panels using property data generated from the manufacturer's actual production.
- C. Performance Requirements:
 - 1. Provide glass-fiber-reinforced precast concrete panels and panel frames capable of withstanding gravity, wind, seismic, and erection design loads as well as the effects of thermal and moisture-induced volume changes, according to load factors and combinations established in PCI MNL 128.
 - 2. Design Loads: As indicated.
 - 3. Design framing systems to withstand design loads with lateral deflections no greater than 1/240 of the wall height.
 - 4. Provide for movement of framing members without damage or overstressing, connection failure, undue strain on fasteners and anchors, or other detrimental effects when subject to a maximum ambient temperature change of 100 degrees F.

1.5 SUBMITTALS

- A. Submit under provisions of Section 01300.
- B. Product Data: Submit manufacturer's data sheets on each product to be used, including:
 - 1. Preparation instructions and recommendations.
 - 2. Storage and handling requirements and recommendations.
 - 3. Installation methods.
- C. Shop Drawings: Indicate dimensions, cross-sections and edge details; metal framing details, location, size and type of reinforcement, including reinforcement necessary for safe handling and erection; and connection details, and relationship to adjacent materials:

1. Design calculations demonstrating compliance with indicated loading conditions and showing flexural ultimate strengths assumed for design, stamped by a structural professional engineer registered in the location of the project.
2. Layout, dimensions, and identification of each panel segment corresponding to installation sequence.
3. Location and details of anchorage devices embedded in panels and shapes, and connection details to building.

D. Samples:

1. Selection Samples: For each finish product specified, two complete sets of color sample, minimum size 6 inches (150 mm) square, representing manufacturer's full range of available colors and patterns for the exposed face of panels.
2. Verification Samples: For each finish product specified, two samples, minimum size 6 inches (150 mm) square, representing actual product, color, and patterns for the exposed face of panels.
3. Do not start fabrication until samples are approved.

E. Maintain plant records and quality control program during production of units. Make records and access to plant available to Architect upon request.

F. Submit certificates of compliance for the following:

1. Admixtures.
2. Portland Cement: Identify the cement brand name, type and mill location used for the quality control sample.
3. Glass Fibers: Submit evidence that glass composition, Portland cement matrix, or both have been designed for glass-fiber reinforced precast concrete panel applications.

1.6 QUALITY ASSURANCE

A. Perform Work in accordance with PCI MNL 128, Recommended Practice for Glass Fiber Reinforced Concrete Panels

B. Manufacturer Qualifications: Provide panels and shapes only from a manufacturer who has demonstrated capability to produce products of the quality and scope required for this project, and with not less than 5 years of successful experience in manufacturing glass-fiber reinforced precast concrete panels and shapes and who is certified in one or more of the following programs:

1. Certified Participant in the Architectural Precast Association's Plant Certification Program for GFRC.
2. Designated PCI-Certified Plant for Group G, Glass Fiber Reinforced Concrete by PCI's Plant Certification Program
3. Retains licensed Professional Engineer for plant and record inspection indicating production, testing and quality control methods comply with PCI MNL-130, Manual for Quality Control: Glass Fiber Reinforced Concrete.

C. Installer Qualifications: A firm which has specialized in erection of glass-fiber reinforced precast concrete panels or architectural precast concrete items similar to those required on this project for not less than 5 years and who is acceptable to manufacturer of glass-fiber reinforced precast concrete panels.

D. Welder Qualifications: Use welders who have been qualified in accordance with AWS D1.1 and AWS D1.4 within the last year.

- E. Mock-Up: Provide a mock-up for evaluation of surface preparation techniques and application workmanship.
 - 1. Finish areas designated by Architect.
 - 2. Do not proceed with remaining work until workmanship, color, and sheen are approved by Architect.
 - 3. Refinish mock-up area as required to produce acceptable work.

1.7 DELIVERY, STORAGE, AND HANDLING

- A. Deliver units to the project site palletized, safely wrapped, packed and labeled and retain until erected.
- B. Store materials in a dry location off the ground, and in such a manner to prevent damage or intrusion of foreign matter.
- C. Handle and transport units in a position consistent with their shape and design in order to avoid excessive stresses or damage.
- D. Store units to protect them from contact with soil, staining, and from physical damage.
- E. Place stored units so that identification marks are easily readable.

PART 2 PRODUCTS

2.1 MANUFACTURERS

- A. Acceptable Manufacturer: Architectural Facades Unlimited, Inc.
- B. Substitutions: Not permitted.

2.2 MATERIALS

- A. Aggregates:
 - 1. Back-up Mix: Washed and dried silica sand or other sand having a history of successful use in glass-fiber-reinforced precast concrete panel construction; passing through a No. 20 sieve.
 - 2. Facing Mix: Fine and coarse aggregate for face mix shall conform to ASTM C 33 except for gradation. Aggregates shall be clean, hard, strong, durable, inert, and free of staining and deleterious materials. Provide aggregate in colors and sizes as required to achieve the panel finish texture and colors indicated on the Drawings.
- B. Portland Cement: ASTM C 150, Type I, II or III. Use the same type, brand and color of portland cement for all panels and shapes. Color shall be as required to obtain the panel facing color indicated.
- C. Admixtures:
 - 1. Air-entraining admixtures, ASTM C 260. ASTM C260, ASTM C494, ASTM C618 or acrylic thermoplastic copolymer dispersion conforming to PCI MNL-130, Appendix E.
 - 2. Polymer Compound: Conform to requirements of PCI MNL-128, Appendix L.
- D. Coloring Agent: ASTM C 979; shall have no adverse effects to glass-fiber-reinforced precast concrete panel set and strength; shall be stable at high temperature; and shall be sunlight fast and alkali-resistant. Color shall be as required to obtain panel facing color selected.

- E. Water for Mixing Concrete: Use potable water.
- F. Glass Fiber: Conforming to PCI MNL-130, Appendix D and specifically designed to be compatible with the aggressive alkaline environment of portland cement based composites or fibers with a history of successful use in portland cement based composites that has been modified to be compatible with the fiber.
- G. Anchors and Loose Attachment Hardware:
1. Structural Steel: ASTM A 36/A 36M.
 2. Cold Drawn Wire:
 3. Anchor Bolts: ASTM A 325.
 4. Pipe: ASTM A 500 Grades A or B.
 5. Tube Steel: ASTM A 500 Grade A or B.
 6. Carbon-Steel Rods: ASTM A 108, cold drawn.
 7. Carbon-Steel Plate: ASTM A 283/A 283M.
 8. Malleable-Steel Castings: ASTM A 47/A 47M.
 9. Carbon-Steel Castings: ASTM A 27/A27M, Grade 60-30.
 10. Finish: Galvanized in accordance with ASTM A 153/A 153M.
- H. Panel Frame Materials:
1. Cold-Formed Steel Framing: Manufacturer's standard C-shaped steel studs, complying with AISI "Specification for the Design of Cold-Formed Steel Structural Members," minimum uncoated steel thickness of 0.0538 inch (1.37mm) of web depth indicated, with stiffened flanges, V-shaped steel track, and of the following steel sheet:
 - a. Metallic-Coated Steel Sheet: ASTM A 653/A653M, structural-steel sheet, of grade required by structural performance of framing and with zinc coating thickness of:
 - 1) G60 (Z180).
 - 2) G90 (Z275).
 - b. Painted, Nonmetallic-Coated Steel Sheet: ASTM A1011/A1011M hot rolled or ASTM A1008/ A1008M cold rolled; nonmetallic coated according to ASTM A 1003/ A 1003M; of grade required by structural performance of framing.
 2. Hollow Structural Sections: Steel tubing, ASTM A500, Grade B, or ASTM A513. Finish hollow structural sections with wall thickness less than 3/16 inch (4.76 mm) as follows:
 - a. Organic Zinc-Rich Primer: SSPC-Paint 20 on surfaces prepared to comply with SSPC-SP6/NACE No.3, "Commercial Blast Cleaning."
 - b. Primer: SSPC-Paint 25 on surfaces prepared to comply with SSPC-SP 2, "Hand Tool Cleaning," or better.
 3. Steel Channels and Angles: ASTM A36/ A36M, finished as follows:
 - a. Organic Zinc-Rich Primer: SSPC-Paint 20 on surfaces prepared to comply with SSPC-SP6/NACE No.3, "Commercial Blast Cleaning."
 - b. Primer: SSPC-Paint 25 on surfaces prepared to comply with SSPC-SP 2, "Hand Tool Cleaning," or better.
- I. Form Materials: Provide form materials that will produce panels having the profile, dimensions and tolerances indicated. Use release agents which are compatible with finish specified and joint sealants proposed for use.
- J. Mixes: Portland cement, water, glass fibers and sand mixed in proportions determined in accordance with PCI MNL-128.

2.3 FABRICATION

03490-6

- A. Fabricate panels in general compliance with PCI MNL-128 and MNL-130.
- B. Molds:
1. Rigid and constructed of materials that will result in finished products conforming to the profiles, dimensions and tolerances indicated on the Drawings.
 2. Release agents; apply and use according to manufacturer's instructions.
- C. Proportioning and Mixing:
1. Carefully measure mix constituents in a manner to achieve the desired mix proportions.
 2. Meter the glass fiber and cement slurry to the spray head at rates to achieve the desired mix proportion and glass content. Check rates in accordance with standard procedures described in PCI MNL-128.
 3. Maintain cleanliness of equipment and working procedures at all times.
- D. Hand Spray Application:
1. Spray apply a mist coat consisting of the matrix without fiber. Applied coating not to exceed 1/8 inch thick in order to avoid an un reinforced surface.
 2. Spray or place face mix in thickness shown on shop drawings.
 3. Spray-up main body of material before the mist coat has set.
 4. Apply by spraying such that uniform thickness and distribution of glass fiber and cement matrix is achieved during the application process.
 5. Consolidate by rolling or such other techniques as necessary to achieve complete encapsulation of fibers and compaction.
 6. Control thickness by using a pin gauge or other approved method. Perform a minimum of 2 measurements per 5 square feet of panel surface with at least 3 measurements per panel.
Perform hand forming of intricate details, incorporate formers or infill material, and overspray before the material has achieved its initial set so as to insure complete bonding.
- E. Premix Application
1. AR glass fiber is pre-chopped to lengths that can range from 3/4" to 1-1/2". The chopped AR glass fibers are weighed and mixed with cement slurry prior to placement into mold. This takes place after mist coat application as described in 2.3 D. 1. Steps 5 thru 7 above to follow.
- F. Inserts and Embedments:
1. Properly embed inserts in built up homogeneous glass-fiber reinforced precast concrete panel bosses to develop their strength. Waste material or overspray is not acceptable to encapsulate inserts or for bonding pads.
 2. Test inserts to establish test data and reduce test values by the appropriate safety factors to determine connection strength to be used in design.
 3. Rigid embedded items bonded to the glass-fiber reinforced precast concrete panel shall not create undesirable restraint to volume changes.
- G. Panel Frame Fabrication:
1. Fabricate panel frames and accessories plumb, square, true to line, and with components securely fastened in accordance with design requirements.
 - a. Fabricate panel frames using jigs or templates.
 - b. Cut cold-formed metal framing members by sawing or shearing; do not torch cut.

Formatted: Indent: First line: 0"

- c. Fasten cold-formed metal framing members by welding. Comply with AWS D1.3 requirements and procedure for welding, appearance and quality of welds, and methods used in correcting welding work.
 - d. Fasten framing members of hollow structural sections, steel channels, or steel angles by welding. Comply with AWS D1.1 requirements and procedures for welding, appearance and quality of welds, and methods used in correcting welding work.
 - e. Weld flex, gravity, and seismic anchors to panel frames.
 - 2. Reinforce, stiffen, and brace framing assemblies, if necessary, to withstand handling, delivery, and erection stresses. Lift fabricated assemblies in a manner that prevents damage or significant distortion.
 - 3. Galvanizing Repair: Touch up accessible damaged galvanized surfaces according to ASTM A 780.
- H. Finish of Exposed Faces: Panel faces shall be free of honeycombs, form marks, concrete droppings or other blemishes that would telegraph through the panel. Provide a finish surface free of laitance, grease, form release treatments, efflorescence, curing compounds or other foreign material that would adversely affect bonding of any subsequent coating.
- 1. Color and texture of exposed face surfaces shall match Architect's design reference panel.
 - 2. Color and texture of exposed face surfaces shall match _____.
 - 3. Color and texture of exposed face surfaces shall match one of the manufacturers standard finishes as selected by the Architect.
- I. Dimensional Tolerances of Finished Units: Provide in accordance with PCI MNL-117 and PCI MNL-128.
- J. Cover: Provide embedded anchors, inserts, and other sprayed in items with sufficient anchorage and embedment for design requirements.
- K. Curing:
- 1. Immediately after the completion of spraying of the panel, cure panels using a method to ensure sufficient strength for removing the units from the form.
 - 2. After initial curing, remove panel from form and place in a controlled curing environment.
 - 3. An acrylic thermoplastic copolymer dispersion may be used as a curing admixture. Only copolymers shown to eliminate the need for moist curing through independent laboratory test data shall be used.
- L. Panel Identification:
- 1. Mark each glass-fiber reinforced precast concrete panel to correspond to identification mark on shop drawings for panel location.
 - 2. Mark each glass-fiber reinforced precast concrete panel with date on which it was cast.
 - 3. Apply markings on surface that will not be exposed in the finished construction.
- 2.4 SOURCE QUALITY CONTROL
- A. Independent Testing:
- 1. Allow Owner's testing agency access to material storage areas, concrete production equipment, concrete placement, and curing facilities.
 - 2. Cooperate with Owner's testing agency and provide samples of materials and concrete mixes as may be requested for additional testing and evaluation.

3. Test glass-fiber reinforced precast concrete panel units in accordance with PCI MNL-130.
- B. Plant Testing:
1. Test glass-fiber reinforced precast concrete panel units in accordance with PCI MNL-130.
 2. Perform testing by an independent testing agency capable of performing the specified tests. Submit copies to the Architect and designated authorities.
- C. Acceptability of Appearance:
1. Finished construction in place shall present a uniform, pleasing appearance when viewed in good typical lighting with the naked eye at a distance of 10 feet and shall show no imperfections at a distance of 20 feet.
 2. The range of total acceptable color (lightness, color saturation and hue) variation shall not exceed CIELAB 3.0 provided that the difference in hue alone does not exceed CIELAB 1.0 as defined by the International Commission of Illumination, 1976 Standards.

PART 3 EXECUTION

3.1 EXAMINATION

- A. Check placement of structural support system to assure a true and level surface for attachment of panels. Do not begin construction until discrepancies that could adversely affect installation of panels have been corrected.
- B. If substrate preparation is the responsibility of another installer, notify Architect of unsatisfactory preparation before proceeding.

3.2 PREPARATION

- A. Clean surfaces thoroughly prior to installation.
- B. Prepare surfaces using the methods recommended by the manufacturer for achieving the best result for the substrate under the project conditions.

3.3 INSTALLATION

- A. Install in accordance with manufacturer's instructions.
- B. Setting:
1. Lift glass-fiber reinforced precast concrete panel units with suitable lifting devices at points provided by the manufacturer.
 2. Set glass-fiber reinforced precast concrete panel units level, plumb, square and true within the allowable tolerances.
 3. Site cutting of panels is not permitted.
- C. Supports and Bracing: Provide temporary supports and bracing required to maintain position, stability, and alignment as units are being permanently connected.
- D. Fastening:
1. Fasten glass-fiber reinforced precast concrete panel units in place by bolting or welding or both as shown on erection drawings.

2. Field welding shall be done by qualified welders using equipment and materials compatible with the base material.
3. Use non-combustible shields during welding operations to protect adjacent Work.

E. Tolerances of Erected Units:

1. Tolerances for location of glass-fiber reinforced precast concrete panel units shall be noncumulative and as listed below. For erection tolerances not listed below, those listed in PCI MNL 117 shall apply.
2. Face width of joint:
 - a. Panel dimension 10 feet or less plus 3/16 inch.
 - b. Panel dimension 10 to 20 feet plus 3/16 inch, minus 1/4 inch.
 - c. Panel dimension greater than 20 feet plus 1/4 inch, minus 5/16 inch
3. Warpage: Maximum permissible warpage of one corner out of plane of the other three shall be 1/16 inch per foot of distance from the nearest adjacent corner or 1/8 inch total after installation.
4. Bowing: Not over $L/360$, where L is the panel length.

3.4 PATCHING AND CLEANING

- A. Patch and clean panels using methods and materials in accordance with manufacturer's instructions.
- B. Patching blemishes using a patching mixture matching the color and texture of surrounding surface.
- C. Use extreme care to prevent damage to panel surfaces and to adjacent materials. Provide protection of adjacent surfaces if required.
- D. Surface must be thoroughly rinsed with clean water immediately after using cleaner.

3.5 FIELD TESTS AND INSPECTION

- A. Quality Control Program: Panel manufacturer shall have an established quality control program in effect at the plant or shall employ an independent testing laboratory approved by the Architect to monitor glass content, spray rate, physical properties and curing period and conditions.
- B. Sampling and Testing:
 1. Prepare test specimens and use test procedures in accordance with PCI MNL-128, Chapter 8 and Appendix A.
 2. Prepare a minimum of 2 test boards per work shift until a production uniformity acceptable to the quality control personnel has been achieved. At such time frequency may be reduced to one board per work shift.
 3. For each board determine glass content by the washout test, flexural ultimate strength and flexural yield strength.
 4. Glass content shall be considered satisfactory if within minus 0.5 and plus 1.0 percent, by weight, of the glass content in the design mix.
 5. Flexural yield strength shall be considered satisfactory if both of the following requirements are met.
 - a. The average of all sets of 3 consecutive strength tests equal or exceed assumed ultimate flexural strength for design purposes.
 - b. No individual test (average of 6 coupons) fall below required assumed ultimate flexural strength for design purposes by more than 10 percent.

6. Submit reports giving proportions, test results, inspection results, unit identification numbers and casting date for each work shift.

C. Rejection:

1. Panels in place may be rejected for any one of the following product defects or installation deficiencies:
 - a. Non-repairable damage incurred during construction operations.
 - b. Ragged or irregular edges.
 - c. Visible form joints or irregular surfaces.
 - d. Panels not conforming to tolerance requirements.
 - e. Foreign material embedded in the face.
 - f. Visible repairs.
 - g. Cracks visible at a distance of 10 feet.
 - h. Panels do not meet design strength requirements.

3.6 PROTECTION

- A. Protect installed products until completion of project.
- B. Touch-up, repair or replace damaged products before Substantial Completion.

3.7 SCHEDULE

- A. Item:

END OF SECTION

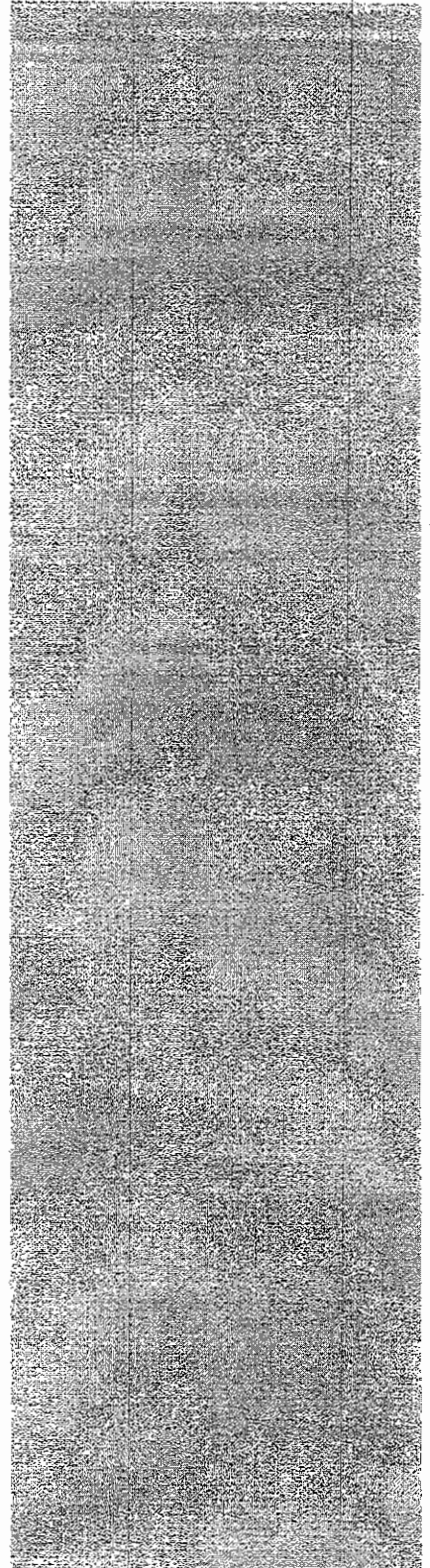

ARCHITECTURAL FACADES

The Ornamental PreCast  Stone Company



CEMENT

www.architecturalfacades.com

600 East Luchessa Avenue, Gilroy, California 95020-7068 • PH 800-346-0826 • FX 408-846-8944

LEHIGH
WHITE CEMENT

Lehigh Cement Company
WHITE CEMENT DIVISION
7660 Imperial Way
Allentown, PA 18135-1040
Phone (610) 366-4600
Fax (610) 366-4638
www.lehighwhitecement.com

November 3, 2008

Architectural Facades
600 East Luchessa Ave
Gilroy, CA 95020

Attention: Nelly Kaleva

Subject: Lehigh White Cement

Dear Ms. Kaleva,

This letter will certify that at time of shipment, Lehigh White Portland Cement, Type I manufactured at the Valles facility with the chemical and physical requirements of the current ASTM C-150 and is Low Alkali Cement containing less than 0.60% total alkali when tested in accordance with ASTM C-114.

If we can be of further assistance, please contact your Lehigh Sales Office:

Best Regards,

Larry Rowland

Larry Rowland
Manager Marketing and Technical Services
Lehigh White Cement Division

LEHIGH WHITE CEMENT

PRODUCT NAME

- Lehigh White Portland Cement Type I
- Lehigh White Portland Cement Type II/V
- Lehigh High Early Strength White Portland Cement, Type III
- Lehigh White Portland Cement - Water Repellent Added
- Lehigh White Masonry Cement, Type N
- Lehigh White Masonry Cement, Type S

MANUFACTURER

Lehigh Cement Company
White Cement Division
7660 Imperial Way • Allentown, PA 18195
Phone (800) 523-5488
(610) 366-4600
Fax: (610) 366-4638
E-mail: info@lehighwhitecement.com
www.lehighwhitecement.com

PRODUCT DESCRIPTION

Portland cement is the most widely used construction material in the world. Since 1897, the name Lehigh has meant quality in the cement industry. Lehigh White Cement has a well established reputation for serving the construction industry with high performance products that encourage creativity and ensure longevity.

Lehigh White Cement is the foremost supplier of white cements in North America; the company actively participates in educational programs, trade associations and industry expositions throughout the United States.

Depending on the application, Lehigh cement products may be specified in Division 3 - Concrete or Division 4 - Masonry.

APPLICATIONS

Lehigh White Portland Cement, Type I

• Lehigh White Type I Portland Cement is recommended for general architectural applications, such as; precast and prestressed architectural concrete, cast-in-place architectural and structural concrete, architectural concrete masonry, swimming pools and spas, colored mortars, ornamental statuary, reflective floors, floor tiles and pavers, cast stone, terrazzo, tile grout, glass fiber reinforced concrete products, concrete countertops, concrete roof tiles, traffic calming and delineation, median barriers, bridge parapets, sound walls, retaining walls, tunnel construction and reflective concrete paving. Lehigh White Type I Portland Cement may be used as a base to produce vibrant and true colors prized in almost any architectural concrete application.

Lehigh White Portland Cement - Type II/V

• Is typically suitable for the same applications as Type I cement. It is often specified when concrete will be exposed to seawater, soils and or ground water that have elevated sulfate contents or in mass concrete work where lower heat of hydration is desired.

Lehigh High Early Strength White Portland Cement, Type III

• Precast and prestressed architectural concrete, architectural concrete masonry units, cast stone, concrete brick, pavers, roof tile, cold weather construction or any application requiring high early strengths.

Lehigh White Portland Cement - Water Repellent Added

• Plastering applications, masonry mortar, tile grout and as a component in the manufacturer of cementitious coatings and water repellent products.

Lehigh White Masonry Cement, Type N

• For use in masonry mortar where a white or bright colored mortar joint is desired; for use in preparing Type N Mortar as described in ASTM Specification C270, Standard Specification for Mortar for Unit Masonry.

Lehigh White Masonry Cement, Type S

• For use in masonry mortar where a white or bright colored mortar joint is desired; for use in preparing Type S Mortar as described in ASTM Specification C270, Standard Specification for Mortar for Unit Masonry.

QUALITY

Lehigh White Portland and Masonry Cements are produced using carefully selected raw materials and rigid manufacturing standards to assure uniform whiteness and strength. When consistent white or bright colors are desired you can depend on Lehigh White Cements.

SUSTAINABILITY

Portland cement is manufactured by combining four of the top five most common elements on earth. White cement concrete is primarily used in architectural applications and does not have to be painted or covered to look great. Concrete construction can significantly reduce energy consumption due to the thermal mass properties of the material, it is durable and has an unsurpassed service life. White Portland cement concrete has high reflectivity values which helps reduce heat island effects.

STORAGE

Lehigh White Portland and Masonry Cements are moisture sensitive materials. Portland cement must be kept dry in order to retain its quality. Bulk Lehigh White Portland Cement should be stored in weather tight bins or silos. Lehigh White Portland and Masonry Cement bags should be kept in a dry area and stored on pallets whenever possible.

AVAILABILITY

Lehigh White Portland Cement is available through a network of distributors throughout the United States. Lehigh White Masonry Cement is widely available through a network of distributors east of the Rocky Mountains. For more information on Lehigh products or technical assistance, visit us online at www.lehighwhitecement.com or phone 800-523-5488.

CAUTION

Portland cement when dry is non-hazardous. When in contact with moisture (such as in eyes or skin) or when mixed with water to make concrete, mortar or grout, it becomes highly caustic and will burn (as severely as third-degree) the eyes or skin. Inhalation of dry Portland cement can irritate the upper respiratory system. For additional safety information please reference our Material Safety Data Sheets available online at www.lehighwhitecement.com or phone 800-523-5488.

WARRANTY

The information and statements herein are believed to be reliable, but are not to be construed as a warranty or representation for which we assume legal responsibility. No other warranty, representation, or condition of any kind, expressed or implied (including NO WARRANTY OF MERCHANTABILITY OR FITNESS FOR A PARTICULAR PURPOSE), shall apply. Having no control over the use of cement, Lehigh Companies will not guarantee finished work, nor shall they be liable for consequential damages.



ARCHITECTURAL FACADES

The Ornamental PreCast ▲ Stone Company



GLASS FIBER

www.architecturalfacades.com

600 East Luchessa Avenue, Gilroy, California 95020-7068 • PH 800-346-0826 • FX 408-846-8944

SAINT-GOBAIN
VETROTEX

Cem-FIL® Material Test/Mill Report®

53/16 PRODUCT

<u>Property</u>	<u>Tested Value</u>
Zirconia Content (ZrO ₂)	16.57%
Loss on Ignition	2.13%
Moisture Content	0.069%
Linear Density (roving tex)	2444
Chopped Strand Filament Diameter	14 μ
Chopped Strand Length	Not applicable

Date: December 20th 2005

*TO
Gobert*

Mr. Francois Gobert
Quality Control Manager
Saint-Gobain Vetrotex España S.A.

MATERIAL SAFETY DATA SHEET

In compliance with EEC Directives 93/112/CE dated 12/10/93 and 2001/58/CE dated 07/27/01
updating Directive 91/155 dated 03/05/1991

And in compliance with ISO standards 11014-1 dated 03/15/94 and ANSI Z400.1 dated 1998

1 - COMPANY - PRODUCTS IDENTIFICATION

MANUFACTURER:

Head Quarters:

Saint-Gobain Vetrotex International S.A.
767, quai des Allobroges, BP 929
73009 Chambéry Cedex
☎ : (33) (0)4 / 79 75 53 00 - Fax : (33) (0)4 / 79 75 53 99

Product on plant:

Saint-Gobain Vetrotex España S.A.
Carretera Madrid-Barcelona, Km 34,500
E-28800 Alcalá de Henares (Madrid)
☎ (34) 1 885 57 00
Fax (34) 1 885 57 03

Saint-Gobain Loreet SA
57, rue du Maréchal de Rochambeau
F-41100 Vendôme
☎ : +33 2 54 73 40 00
Fax : +33 2 54 72 28 92

Saint-Gobain Revetex S.r.l.
Corso Rigola 89
I-13100 Vercelli
☎ : +39 0161 215810
Fax : +39 0161 257121

Saint-Gobain Vertex, s.s. - Plant 3
Záhradní 256
CZ-67125 Hodonice
☎ : + 420 624 207 111
Fax : + 420 624 207 275

PRODUCT IDENTIFICATION:

"AR continuous filaments glass fibers"

Commercial brand: ARcotex®, Cem-FIL® or Anti-Crak®

Contact in case of emergency:

- Environmental Industrial Hygiene and Security Director of The Reinforcement Branch of Saint-Gobain
- Saint-Gobain Vetrotex International S.A.
Phone +33 4 79 75 53 00; Fax +33 4 79 75 54 03
- sgvx_webmaster@saint-gobain.com

2 - COMPOSITION - INFORMATION ON CONSTITUENT PARTS

Glass fibres for reinforcement are basically sold as:

SAINT-GOBAIN
VETROTEX

ASSEMBLED ROVINGS DIRECT ROVINGS RO99[®]
CHOPPED STRANDS CHOPPED STRANDS MATS
TEXTILE YARNS MILLED FIBERS
CONTINUOUS FILAMENT MAT

On Saint-Gobain Vetrotex product packing, these general names are followed by a code number.

This Material Safety Data Sheet is valid for all these products.

Glass fibres can be considered as ARTICLES, as fibres are defined as articles in the manual of decisions for implementation of the sixth and seventh amendments to directive 67/548/eec on dangerous substances (EU Directives 79/831/eec and 92/32/eec) or in the USA by the American TSCA (Toxic Substances Control Act) or EPA 40 CFR 710.2 and also some other national regulations (DSL in Canada for instance).

These articles are mixtures of AR GLASS in the form of continuous strands and a SIZE with, in addition, a BINDER in the case of mats.

The CAS number of glass fibre is 65997-17-3 (corresponding to the oxides used for production).

AR Glass is an alkaline and acid resistant glass. Its composition (expressed in oxides) is within the following percentages:

SiO ₂	55-75%
ZrO ₂	15-20%
Alkaline oxides (Na ₂ O, K ₂ O)	11-21%
Alkaline terreous oxides (CaO, MgO....)	0-6%
B ₂ O ₃	0-2%
Al ₂ O ₃	0-5%
TiO ₂	0-3%
F ₂	0-2 %

AR Glass contains traces of naturally-occurring radioactive materials. The total content of Uranium and Thorium is less than 500ppm with a total specific activity below 20 Bq/g.

SIZE is a mixture of chemicals applied to the glass strands in a maximum quantity of 2.5% - more generally less than 1.5%.

Most of this mixture is made up of basically non reactive high molecular weight polymers not listed as substances in the 1981 European Inventory of Existing Commercial Substances (EINECS) nor in the ELINCS appendices (European List of Notified Chemical Substances) nor in the American TSCA lists.

Revision 13/April 2007 2/15

In some cases, sizes are prepared from polymers with reactive sites or containing reactive monomers included in these lists. Most of the reactive sites are polymerised during the manufacturing process. However a very small reactivity may remain which justifies the precautionary measures listed in Chapter 8 below.

A second type of ingredient present in almost all sizes is a member of the organo-silane family. These products account for less than 0.05% of the final weight of sized glass. These products are included in lists of products requiring 'hazardous product' labelling in a pure state for example in Europe R23/25 'toxic if swallowed or inhaled', R21 'harmful in contact with the skin', R36 'irritant for the eyes'.

The manufacturer considers this risk as negligible as, although listed as dangerous products, the concentration is extremely low and they are polymerised during the production of AR Glass fibres.

Other products can be used in sizes. Usually the content is extremely low (under 0.1% of total weight) and as a general rule such products are not on the dangerous product lists or, as they have reacted, any possible risk has been reduced.

BINDERS FOR MATS are high molecular weight polymers deposited in quantities under 10% and polymerised on chopped or continuous glass strand mats. They are not on dangerous products lists.

If so requested by medical authorities, the Chemical Abstract Service (CAS) reference numbers for the ingredients used for a given size or binder can be communicated but must remain for the confidential use of medical authorities.

3 - HAZARD IDENTIFICATION

Continuous strand glass reinforcing fibres are not significantly hazardous

Details about chemical hazards are given in paragraph 2. Toxicological aspects are developed in detail in chapter 11. The essential point to remember is that glass filaments are not "respirable" as they are over 3µm in diameter and have been shown not to cause lung cancer.

Hazards identified are:

- mechanical irritation (itching)
- the formation of non fibrous dusts (broken pieces of different sizes) and non respirable filaments
- extremely rare possibilities of allergy.

4 - FIRST AID

INHALATION: remove from the scene of exposure to fresh air

SKIN CONTACT: wash copiously with lukewarm soapy water without rubbing excessively

EYE CONTACT: flush in running water (for at least 10 minutes) and consult if needed a doctor

5 - FIRE FIGHTING

In case of fire, glass fibres are not flammable, are incombustible and don't support combustion.

Only the packaging (plastic film, paper, cardboard, wood) and the small amounts of size or binder are likely to burn. Combustion gases are basically carbon dioxide and water vapour. There may be small quantities of carbon monoxide and other substances which make it necessary to use protective devices in the event of a major fire.

RECOMMENDED EXTINGUISHING MEDIA: water or powder

6 - ACCIDENTAL SPILLAGE

PERSONAL PROTECTION: See Chapter 8.

ENVIRONMENTAL PROTECTION:

In leaching tests glass fibre wastes did not emit any significant quantities of dangerous products and they can therefore be considered as **Inert Industrial Wastes**, or even **Common Industrial Wastes**, as defined by national and local regulations. All waste and scrap material should be disposed of in accordance with applicable national, federal, state and local regulations.

CLEANING:

It is recommended to identify the chemical nature of the fibres found in working atmospheres correctly, in particular in insulation wools and mineral fibres like asbestos which are sometimes present and can be confused with continuous glass filaments.

Country	Dusts	TWA (Time-Weighted Average concentration) (mg/cu.m. for 8 hours work)	Fibres	TWA (Time-Weighted Average concentration) (Fibres/ml for 8 hours work)
Austria	fine	6	total	0.5
Belgium	total	10	No regulation	
Denmark	respirable	5	total	1
	total	10		
Finland	total	10	total	1
France	total	10	respirable	1
Germany	respirable	3	respirable	0.25
Great Britain	respirable	5	respirable	2
	total	10		
The Netherlands	respirable	2	total	1
	total	10		
Ireland	respirable	5	respirable	2
Italy	respirable	3	total	1
	total	10		
Norway	respirable	5	total	1
	total	10		
Portugal	total	4	total	1
Spain	total	10	total	1
Sweden	respirable	5	total	1
	total	10		
Switzerland	total	6	respirable	0.5
USA	total	5	total	1

PERSONAL PROTECTION EQUIPMENT:

Respiratory protection: during occasional operations releasing high quantities of dust, wear minimum FP1 or preferably FP2 EEC approved dust masks. Type 3M 8710 or 3M 9900 respirators approved according to American National Institute For Occupational Safety And Health (NIOSH) directives, can be used, for example.

Vacuum clean, sweep or shovel into containers normally used for glass fibre waste (selective collection).

7 - HANDLING & STORAGE

HANDLING (Technical measures / Precautions / Safe handling advice):

It is preferable to avoid prolonged contact with the skin: wear gloves, garments with sleeves and long leggings or protective overalls, goggles, and dust masks. Glass filaments and dusts must be removed from work garments with a vacuum cleaner and not blown off with compressed air jets. Wash work garments separately from other clothes.

STORAGE:

Technical measures: respect the stacking procedure recommended for each type of product.

Storage conditions: store away from excessive humidity to prevent damage to the product and to the packing materials which could lead to storage safety problems.

Incompatible material: not relevant.

8 - EXPOSURE CONTROL - PERSONAL PROTECTION

TECHNICAL MEASURES

Use every appropriate means (suction, modification of manufacturing methods to reduce fibre dust...) to try to reduce the concentration of fibres in the air likely to cause irritation.

TEST PARAMETERS

Test ambient atmospheres in which glass fibre is used regularly to determine levels of

- "non respirable" and "respirable" filaments,
- "non-respirable" and "respirable" dusts.

Legal requirements for respirable and non-respirable dusts and fibres vary from country to country (or do not even exist). The table below (prepared using the knowledge we currently possess) shows the limits applicable in different countries for Time-Weighted Average (TWA) exposure.

Protection of hands and other exposed parts of the body:
gloves for the hands, long-sleeved garments and long leggings to prevent irritation.

People with delicate skin should apply barrier cream to exposed skin areas.

Eye protection: safety goggles (or masks) or safety glasses.

During normal handling and use the product doesn't lead to an exposure above 1 mSv/year (1760 hr/year).

9 - PHYSICAL AND CHEMICAL PROPERTIES

PHYSICAL STATE:	solid
FORM:	continuous or chopped or mats of fibre made up of continuous, parallel filaments glued together.
COLOUR:	white or yellowish white
ODOUR:	none, except for some products from which a slightly basic or acid odour is sometimes released when a pallet or carton is opened. This odour never indicates that an eventual toxic product has been released in a dangerous amount.
pH:	not applicable
SPECIFIC TEMPERATURE AT WHICH CHANGES IN PHYSICAL STATE OCCUR:	
Softening point (Littleton point) :	approximately 860°C
Melting point:	approximately 1280°C (viscosity temperature 1300 p)
DECOMPOSITION TEMPERATURE:	Sizes and mat binders start to decompose at 200°C
FLASH POINT:	none
EXPLOSIVE PROPERTIES:	none
DENSITY (molten glass):	2.7 g / cu. cm.
SOLUBILITY:	very low solubility in water. Sizes and binders can be partially (and even totally) dissolved in most organic solvents.

Revision 1/April 2007 1/13

10 - STABILITY AND REACTIVITY

STABILITY

Stable in normal use and storage conditions, and in normally foreseeable usage conditions.

HAZARDOUS REACTIONS

Glass reinforcement strands are stable and never generate hazardous chemical reactions.

HAZARDOUS DECOMPOSITION PRODUCTS

In continuous combustion conditions, in addition to water vapour and CO₂, small quantities of CO and NO_x may be released from the combustion of the size and/or the binder. Other products may be released in limited quantities, depending on combustion conditions. This is why it is recommended to use high-performance gas masks, when fighting intense fires.

11 - TOXICOLOGICAL INFORMATION

ACUTE TOXICITY: not relevant

LOCALISED EFFECTS: possible temporary irritations

This irritation is of a purely mechanical and temporary nature. It disappears when exposure is ended. It can affect the skin, the eyes and the upper respiratory tracts. In Europe, mechanical irritation is not considered to be a health hazard within the terms of European directives 67/548/EEC for hazardous products. This is confirmed by the fact that EC Directive 97/69/EC for mineral fibres does not stipulate the need to use an Xi (irritant) label nor a classification for continuous strand glass fibres (which in this Directive only apply to glass insulation wools in some circumstances).

SENSITISATION: some allergies to continuous strand glass fibres have been declared. All sizing mixtures are tested for their wet state sensitising properties when developed by Saint-Gobain Vetrotex and are only adopted if they have no or a very low sensitisation level. In case of the allergy is confirmed, remove the person from the scene of the exposure.

LONG TERM TOXICITY: CARCINOGENIC RISKS

Continuous strand glass fibres are not respirable (i.e. do not penetrate the lung alveoli). This is because fibres are over 3µm in diameter (and, mostly, over 10µm). Even after handling, the length of the finest dusts is also well over 5µm and the length / diameter ratio is greater than 3 : 1.

Revision 3/April 2007 6/13

These are the values determined by the World Health Organisation (WHO) for the definition of respirable fibres.

Regulatory situation:

None of the following official organisations have attributed any risks of cancer during the production and use of continuous filament glass fibres:

During its congress in June, 1987, World Health Organisation (WHO) through the IARC (International Agency of Research on Cancer) examined all laboratory Studies using animals and epidemiological studies carried out on continuous strand glass reinforcement fibres.

The conclusion was that glass filaments are not classified as to their carcinogenicity. They belong to the Group 3 of IARC. This classification has been confirmed by the IARC Working Group meeting of October 2001.

The International Labour Office (ILO) and the CSIP (Chemical Safety International Program) came to the same conclusions in a congress held in 1987.

European Commission Directive 97/69/EC dated 3/12/97, the 23rd amendment to Directive 67/548/EEC which concerns classification, packing and labelling of hazardous substances did not think it necessary to include glass fibres as having carcinogenic risks.

Most European Union member nations have transposed this Directive into their national law and adopted the same conclusions:

Country	Reference of transposition documents of Directive 97/69/EC
Austria	Chemikalienverordnung 1999
Belgium	French implementation by « Koninklijk Besluit » of 15.1/99 published on 24/2/99
Denmark	BEK N°11/1999.01.09 (Ministry of Environment)
Finland	Landskapforordning 23/04/98 and 24/02/98 and List of Hazardous Chemicals 16.12.98
France	Arrêté ministériel du 28/08/98, Circulaire DRT 99/10 du 13/8/99
Germany	4th adaptation of the German Gefahrstoffverordnung 1999
Great Britain	The chemicals (Hazard Information and packaging for supply) (amendment) Regulations 1998. 6/1/99
Greece	Not available
The Netherlands	Wijzigingsbesluit (Stb. 217,2001)
Ireland	Statutory Instruments S.I. N°513 of 1998. European Communities (Classification, Packaging, Labelling and Notification of Dangerous Substances) Amendment N°2 Regulation 1998. Effect on 22 December 1998.

Italy	Decreto ministeriale del 01/09/98, Gazzetta Ufficiale-Serie generale-del 19/11/98 n271 pag. 16, decreto del 2 feb 1999, circolare:n°4 del 15/03/1999
Luxembourg	Règlement Grand Ducal du 31/10/98
Portugal	Non disponible
Spain	Bulletin Oficial del Estada (11/09/98)
Sweden	KIFS 1998 : 7

OSHA (Occupational Safety and Health Administration) and NTP (U.S. National Toxicology Program), official American organisations, have not listed continuous strand glass fibres as hazardous substances and the ACGIH (American Conference of Governmental Industrial Hygienists) has classified them as A4 (not classified as carcinogenic for Man).

No new studies have led the organisations to revise their position on this subject.

Most laws and studies concerning respirable fibres do not apply to continuous filaments reinforcement fibres.

For example,

- The concentration of respirable fibres in the atmosphere (1 fibre / cu.m.) fixed by French circular 95/04 dated 12/01/1995 (in addition to that dated 19/07/1982) from the French Ministry for Work does not apply to glass reinforcement fibres (which are not respirable).
- Cancer risk index KI defined in German TRGS 905 does not apply to non-respirable continuous filament glass fibres.

Epidemiological and laboratory studies

No epidemiological and laboratory studies carried out up until now demonstrate in a scientifically significant way any risk of cancer related to reinforcement fibres.

Several recent epidemiological studies (Chiappe 1997, Boffetta 1997) confirmed the absence of excessive mortality due to cancer in people working in glass fibre manufacturing facilities vs. control populations.

Revision: 1/April 2007
10/13

A recent study published in 2000 by the IOM (Institute of Occupational Medicine in Edinburgh) addressed the inhalation of E-glass microfibres by animals at concentrations at least 1000 times higher than those encountered when using glass fibres demonstrated carcinogenic risk. These microfibres are not part of the product range produced and sold by Saint-Gobain Vetrotex and these findings are not likely to change current opinions for the glass fibres described in this MSDS.

Handling glass fibres

When glass fibres are chopped, milled or sanded they are cut perpendicular to strand length and no smaller diameters filaments are generated. Conversely, significant quantities of dust can be generated which is why it is recommended to use personal protection. In dusts, also present in some products (chopped strands, crushed fibres) some studies have shown very low quantities of particles with fibrous aspects ($l/d > 3$), short (but nevertheless longer than $5 \mu\text{m}$) and with an apparent diameter of under $3 \mu\text{m}$.

Quantities measured in work atmospheres are 50 to 100 times lower than all the limits fixed for respirable fibres, but when there is a high risk of dust generation it is strongly recommended to wear masks.

MUTAGENIC RISKS, TERATOGENIC RISKS, RISKS FOR REPRODUCTION:

Continuous strand glass reinforcement fibres have no known risks.

12 - ECOTOXICOLOGICAL INFORMATION

AR Glass is not biodegradable.

Sizes or binders are organic materials slowly and only partial dissolved by natural agents like water. As the concentration of the ingredients in the mixture and ingredient solubility are low and as they have not been classified as hazardous, glass reinforcement strands are considered to have no adverse ecotoxicological effects.

Glass fibres and sizing products were not listed as products likely to destroy the ozone layer by the 1987 Montreal Protocol (Class 1 or Class 2). These lists are included in EC Regulation n° 3093/94 and in section VI of amendments to the "Clean Air Act" by the American Environmental Agency (EPA).

Glass fibre sizes and binders do not contain PCB (Polychlorinated biphenyl) or and other polyaromatic products of the same type.

Revised on 3/April 2007
11/13

13 - WASTE DISPOSAL

Depending on local regulations, glass fibre wastes can either be considered as inert waste or as common industrial waste. As such they can be buried in landfills approved for these categories.

Glass fibres waste cannot be destroyed by incineration, and can damage incinerators by the formation of a vitrified mass.

Clean cardboard, wood, plastic (film or bags) and packaging can be eliminated in units specific to these products (i.e. for recycling or use as fuels).

14 - TRANSPORT

INTERNATIONAL REGULATIONS:

Glass reinforcement fibres are not considered as hazardous goods by transport regulations.

It is not one of the 13 hazardous classes listed in international regulations.

15 - REGULATORY INFORMATION

AR continuous filaments glass fibers do not require hazardous product labelling (see Chapter 11).

General hygiene and work safety regulations apply (see Chapter 8).

16 - OTHER INFORMATION

FOOD ENVIRONMENTS: Appendix III of European Directive 2002/72/EC defines the compatibility of pure glass fibres with food environments as additives to plastics. However the fact that sizing products should be shown on the current list of European Commission approved products, the BGVV LII list in Germany or the Food and Drugs Administration lists (FDA) in the USA means that a case by case study must be made if a Saint-Gobain Vetrotex range product is used to reinforce a plastic material in contact with food. Consult the Saint-Gobain Vetrotex Service for further information.

CONTACT WITH POTABLE WATER: As regulations differ from country to country, every question must be examined individually with the relevant Saint-Gobain Vetrotex Services.

This Material Safety Data Sheet is in addition to the Product Specification file and other technical documents issued by SAINT-GOBAIN VETROTEX, but do not replace them.

The information given by this document is based on the date shown. It is given in good faith.

Furthermore, users attention is drawn to the possible risks run when the product is used for any purpose other than the one for which it was designed.

This MSDS does not exempt users from knowing and applying the rules regulating their activities. Users assume full responsibility for applying the appropriate safety measures when the product is used.

For all additional information, users should contact their local Saint-Gobain Vetrotex agent or the Saint-Gobain Vetrotex International Environment, Health and Safety Director.

ARCHITECTURAL FACADES

The Ornamental PreCast Stone Company



FORTON

www.architecturalfacades.com

600 East Luchessa Avenue, Gilroy, California 95020-7068 • PH 800-346-0826 • FX 408-846-8944



Engineered Polymer Solutions
5501 East Stauson Ave.
Los Angeles, CA 90040
Telephone: (323) 726-7272

Certificate of Analysis

Ship To: BALL CONSULTING LMD WAREHOUSING
3136 E VICTORIA STREET
DOMINGUEZ, CA 90910

Ship Date: Thursday, October 09, 2008
EPS Sales Order Number: 2483775
Customer PO Number:
Customer Product Code:

Lot Number: 8T50022585

22585

EPS 2774

Specification	Result	Minimum	Maximum
% NVM (Solids)	50.80	50.0	52.0
pH	5.23	8.00	10.00
Weight per Gallon	8.74	8.70	8.90
Particle Size	0.137	0.130	0.250
Brookfield Visc (cps)	160.0	100.0	300.0
Grit (ppm)	< 50		50

EPS products are made with high quality raw materials by people dedicated to doing it right the first time and to excellent service. This product is certified to meet all of our stringent specifications.

This product has been evaluated for clarity and cleanliness after packaging and thereby certified to meet all our quality standards.

Quality Assurance

Shipping Department



Your Technical Specialists For
Forton[®] Modified GFRC
(Glass Fiber Reinforced Concrete)

The long term physical properties of GFRC modified with FORTON[®] polymer show significant improvement, resulting in improved long term durability.

Additional benefits include:

- Significantly increases the tensile and flexural properties and overall physical characteristics of GFRC
- Eliminates the need for a 7 day wet cure regime
- Reduces crazing and drying shrinkage cracks
- Reduces moisture absorption
- Increases aged flexural strain to failure
- UV stable
- Reduces efflorescence
- Lower water/cement ratio for higher strengths

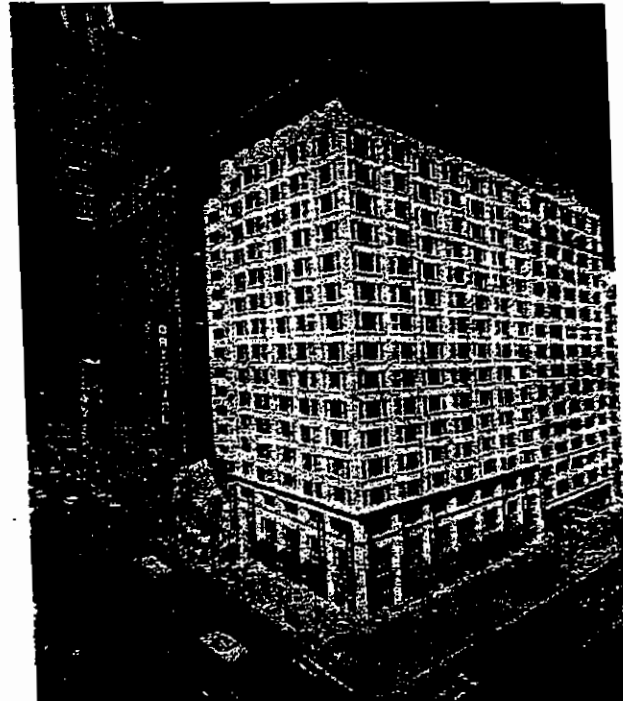

Chicago Art Institute Dormitory

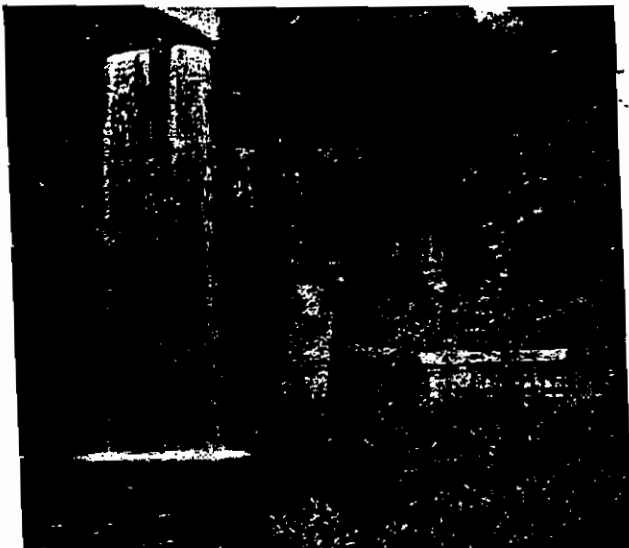

Cheung Kong Park, China

Uses of Polymer Modified GFRC:

- Architectural panels and ornamentation
- Artificial Rocks
- Planters and flower pots
- Garden statuary
- Furniture
- Countertops and tiles
- Roof slates
- Terra Cotta replacement units

www.Ball-Consulting-Ltd.com

338 Fourteenth Street, Ambridge, PA 15003, Phone: 800-225-2873, Fax 724-266-1504, email: ball@ball-consulting-ltd.com
4665 South Ash, Suite G15, Tempe, AZ 85282, Phone: 888-967-7727, Fax: 480-967-8113, email: sshafer@ball-consulting-ltd.com
246 Shady Oaks Circle, Lake Mary, FL 32746, Phone: 407-718-9727, Fax: 407-323-6431, email: psheres@ball-consulting-ltd.com



**GFRC BACKUP MIX DESIGN
GFRC FLEX ANCHOR DESIGN
(PER SACK OF CEMENT)**

		MIX	UNITS
CEMENT:	LEHIGH WHITE: (1 sack)	94	LBS
AGGREGATE:	30 MESH SAND	65	LBS
	TOTAL FINE AGGREGATE	65	LBS
ADDITIVES:			
	5% CHOPPED FIBER by weight	8.35	LBS
POLYMER CURING AGENT:	BALL FORTON	23	LBS
	WR GRACE ADVACAST	4	oz
	WR GRACE DARATARD	2	oz
	TOTAL ADDITIVES:	31.72	LBS
WATER		10	LBS



JOB: VENTURA COLLEGE

**GFRC FACE MIX DESIGN
(PER SACK OF CEMENT)**

		MIX	UNITS
CEMENT:	LEHIGH WHITE	94	LBS
AGGREGATE:	30 MESH SAND	100	LBS
	TOTAL FINE AGGREGATE	100	LBS
ADDITIVES:			
	COLOR: DAVIS 870 BLACK	870	GRAMS
	DAVIS C1191 YELLOW	200	GRAMS
	DAVIS 5370 GREEN	150	GRAMS
WATER CURING AGENT:	BALL FORTON	23	LBS
	WR GRACE ADVACAST	4	OZ
	WR GRACE DARATARD	2	OZ
	TOTAL ADDITIVES:	26.542	LBS
WATER		10	LBS

Ball Consulting Ltd.

Suite G15
4665 S Asn Ave.
Tempe, AZ 85282
Tel: 480.967.7727
Fax: 480.967.8113
www.ball-consulting-ltd.com

Mesa Precast
Terry Partain
415 S Price Rd
Tempe, AZ 85281

Dear Terry,

We certify that Forton VF-774 meets the attached specifications for a GFRC curing agent established by the Precast / Prestressed Concrete Institute.

We are not responsible for improper use of the product.

Sincerely

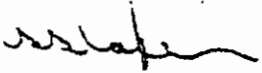

Scott Shafer
West Region Manager



Forton VF-774

Technical Data

May 8, 2007

Description

- Water based, all acrylic co-polymer emulsion formulated to comply with PCI MNL 130, Quality Control Manual, Appendix L for curing admixtures used in GFRC.
- VF-774 also has long term natural ageing data to verify that its use in GFRC composites improves aged flexural properties.
- VF-774 can be used in precast concrete to reduce absorption, maintain color uniformity, and reduce or eliminate crazing and efflorescence.
- It is also used in concrete repair products and bonding agents due to its superior adhesive properties.

Physical Data (also MNL 130 specification)

- | | |
|---|------------------------|
| ○ Solids by weight | 51% ($\pm 1\%$) |
| ○ Viscosity 23°C (Brookfield, Spindle 2/50 rpm) | 100 – 300 cps |
| ○ pH | 8 – 10 |
| ○ Density at 20°C | 1055 kg/m ³ |
| ○ Tg | 11°C |
| ○ Particle Size | .1300 - .2500 |
| ○ Grit | 0 – 50 ppm |

Storage

- Forton VF-774 should be stored in a closed container, in a dry environment at storage temperatures between 5°C and 30°C.
- Storage should be enclosed, out of direct sun light and away from direct sources of heat.

Shelf Life

- With proper storage conditions the normal shelf life will typically be 9 months.

www.Ball-Consulting-Ltd.com

338 Fourteenth Street, Ambridge, PA 15003, Phone: 800-225-2673, Fax 724-266-1504, email: ball@ball-consulting-ltd.com
4665 South Ash, Suite G15, Tempe, AZ 85282, Phone: 888-967-7727, Fax: 480-967-8113, email: sshaffer@ball-consulting-ltd.com
246 Shady Oaks Circle, Lake Mary, FL 32746, Phone: 407-718-9727, Fax: 407-323-6431, email: psheres@ball-consulting-ltd.com



Why use Forton VF-774 in GFRC?

This question is asked by new, and old, GFRC producers when presented with adding the Forton VF-774 co-polymer to their batch.

The two primary and very extensively tested and documented reasons to use the VF-774 in the batch are:

- The elimination of the 7-day wet cure required to achieve the maximum strengths of the GFRC matrix at 28 days.
- To significantly improve the long-term physical properties of the GFRC composite, especially the aged flexural strain to failure.

In addition to these very important points, there are other points that if taken individually, are hard to quantify, but if taken collectively, contribute to a high quality and high performance GFRC product.

These reasons are:

- UV stability of the Forton polymer so that architectural finishes maintain their "as produced" colors.
- Improved workability of the mix at low water/cement ratios, which further enhances the strength of the cured concrete.
- Easy spraying of vertical surfaces without having the face mix sag.
- Complete dispersion of iron oxide pigments for batch-to-batch color consistency of face mixes
- Hard cured face mixes for better sand blasting uniformity.
- Tighter, denser cured product, which reduces absolute moisture absorption and vapor permeability while at the same time significantly reducing the rate of absorption as a function of time.
- Elimination of crazing and spider cracking in the face mix due to the soft polymer particles in between the cement particle and the sand grain.

When evaluating polymers for GFRC, you should know the following details of the product:

- Polymer chemistry: not all white, milky liquids are equal in performance. Many are not UV stable, nor are they alkali stable in the high pH cement matrix. Some will re-emulsify after curing if they get wet.
- Particle size: this controls the effect of pigmentation and color uniformity batch to batch. If this varies, the same amount of pigment will show a different color in the panel.
- Molecular weight: influences the durability of the polymer in the matrix.
- Polymer solids: you are paying for the amount of polymer solids in the liquid. The higher the polymer solids the better value for your dollar.

www.Ball-Consulting-Ltd.com

338 Fourteenth Street, Ambridge, PA 15003, Phone: 800-225-2673, Fax 724-266-1504, email: bail@ball-consulting-ltd.com
4665 South Ash, Suite G15, Tempe, AZ 85282, Phone: 888-967-7727, Fax: 480-967-8113, email: sshafer@ball-consulting-ltd.com
246 Shady Oaks Circle, Lake Mary, FL 32746, Phone: 407-718-9727, Fax: 407-323-6431, email: psheres@ball-consulting-ltd.com

- Defoamer: contrary to normal precast, you do not want additional air entrained in the GFRC composite. VF-774 contains additional defoamer to maintain a high quality slurry through the rigors of high shear mixing and spraying.

Description of Forton VF-774

- Forton VF-774 is an all acrylic thermoplastic co-polymer emulsion.
- It is water-based, non-hazardous material with a polymer solids content of 51%.
- Complies with PCI plant certification program specification Appendix L.
- See Ball Consulting Ltd. Data Sheet for VF-774 dated May 8, 2007.
- Can be shipped in drums, totes or bulk tankers, normally within 10 working days of receipt of order.

When to use Forton VF-774

- The addition of Forton VF-774 to GFRC of any normal cement/sand ratio insures the maximum 28 day matrix strengths, which in turn makes a high quality GFRC composite.
- Forton VF-774 is used to eliminate the 7-day wet curing program required of GFRC to obtain the highest matrix strengths. These strengths are factored into the design equations for the finished product.
- The use of Forton VF-774 will reduce color variation in panels.
- It will virtually eliminate drying shrinkage cracks in face mixes.
- It improves the thermal cycling properties of the GFRC panels in situ by reducing the amount of moisture penetration.
- Using Forton VF-774 will improve the spraying of vertical surfaces and the pumping of GFRC pre-mix.
- There is a plastifying effect when using Forton VF-774 that is synergistic with the use of super plasticizers, giving good workability at low W/C ratios.

Mix Design

The normal Forton VF-774 loading in a GFRC mix is between 5 to 7% polymer solids to the weight of cement. This amount is determined by the composite properties desired in the finished product. The higher the amount of polymer, the more water tight and ductile the part. The inverse would be true for lower amounts.

<u>Typical Mixes</u>	<u>Spray Chop</u>	<u>Premix</u>	<u>Micron HS</u>
Portland Type I	100	100	80
Silica Sand	100	85	100
Forton VF-774	12-14	12-14	12-14
Water	Counting the water in the polymer, the free water is adjusted to desired W/C ratio.		
Cem-FIL A-R fiber	5% by weight	3% by weight	3 or 5%
Micron HS			20
Superplasticizer	4 to 12 oz. adjust workability		

Units can be in pounds or kilos

www.Ball-Consulting-ltd.com

338 Fourteenth Street, Ambridge, PA 15003, Phone: 800-225-2673, Fax 724-266-1504, email: ball@ball-consulting-ltd.com
 4665 South Ash, Suite G15, Tempe, AZ 85282, Phone: 388-967-7727, Fax: 480-967-8113, email: sshaffer@ball-consulting-ltd.com
 246 Shady Oaks Circle, Lake Mary, FL 32746, Phone: 407-718-9727, Fax: 407-323-6431, email: psheres@ball-consulting-ltd.com

ARCHITECTURAL FACADES

The Ornamental PreCast ▲ Stone Company



ADMIXTURE

www.architecturalfacades.com

600 East Luchessa Avenue, Gilroy, California 95020-7068 • PH 800-346-0826 • FX 408-846-8944

Grace Construction Products

W.R. Grace & Co. - Conn.
293 Wright Brothers Avenue
Livermore, CA 94550

T 915-443-9700
www.graceconstruction.com

11/4/2008

Nelly Kaleva
Architectural Facades
600 E. Luchessa Ave.
Gilroy, California 95020

Project Name: General
Product Selected: Daratard® 17

GRACE

This is to certify that the Daratard 17, a Retarder, as manufactured and supplied by Grace Construction Products, W.R. Grace & Co. - Conn., is formulated to comply with the Specifications for Chemical Admixtures for Concrete, ASTM: C494, Type D, AASHTO: M154, Type D.

Daratard 17 does not contain calcium chloride or chloride-containing compounds as a functional ingredient. Chloride ions may be present in trace amounts contributed from the process water used in manufacturing.

The foregoing is in addition to and not in substitution for our standard Conditions of Sale attached.

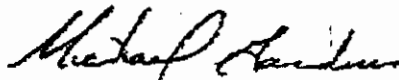

Mike Gardner
Western Region Technical Services Manager

CONDITIONS

All orders are accepted and all sales are made subject only to the provisions of the written contract between us under which the order is placed, or if no such contract exists, subject only to the terms on the face hereof and to the following provisions.

1. Delivery and Freight, Risk of Loss, Title to and all risk of loss of all goods sold hereunder shall pass to Buyer upon delivery f.o.b. W. R. Grace & Co. s (Grace) plant to an agent of the Buyer including a common carrier, notwithstanding and pre-emption or allowance of freight by Grace. If Grace pays freight Grace shall have the right to select the carrier, routing and means of transportation; provided that Buyer may make an alternate selection and pay Grace s additional costs, if any.

2. Freight, Weights and Orders.

(a) Whenever Grace is to pay freight Grace shall have the right initially to designate routing and means of transportation. If Buyer requires a more expensive routing and/or means of transportation Buyer shall reimburse Grace for any extra cost involved. **GRACE SHALL NOT BE LIABLE FOR ANY DELAY IN TRANSPORTATION HOWEVER OCCASIONED.**

(b) Grace s invoice weights, volumes, sizes, and taxes shall be treated as prima facie correct except that in case of bulk shipments by railroad, tank car or otherwise carriers weights shall be accepted as conclusive.

(c) Buyer s orders are not binding upon Grace until accepted in writing by an authorized employee at Grace s offices.

3. Examination, Suitability and Claims.

Buyer shall examine and test each shipment of goods promptly upon delivery to Buyer and before any part of the goods has been changed from its original condition and Buyer hereby waives all claims (for any cause) after any part of the goods has been treated, processed or changed in any manner (except for reasonable test quantities). Buyer assumes sole responsibility for determining whether the goods are suitable for their contemplated use (whether or not such use is known to Grace). Buyer waives all claims of which Grace is not notified in writing within thirty (30) days after delivery of the goods or in respect of goods disposed of or returned without Grace s consent.

4. Warranties, Remedies and Limitations.

(a) Grace warrants to Buyer that at the time of delivery the goods sold hereunder will conform substantially to the description on the face hereof. Grace s liability and Buyer s remedy under this warranty are limited in Grace s discretion to replacement of goods returned to Grace which are shown to Grace s reasonable satisfaction to have been nonconforming or to refund of the purchase price, or, if not paid, to a credit in the amount of the purchase price. Transportation charges for the return of nonconforming goods to Grace and the risk of loss thereof will be borne by Grace only if returned in accordance with written instructions from Grace.

(b) Grace warrants that the goods will not in and of themselves infringe any patent of the United States or Canada. Grace s liability under this warranty is conditioned upon Buyer s giving prompt written notice of any claim of patent infringement made against Buyer. All information available to Buyer in respect of the claim, and Buyer s granting Grace exclusive control of its settlement and/or litigation. Grace may discontinue without liability delivery of the goods if in Grace s opinion their manufacture, sale or use would constitute patent infringement. If the use or resale of the goods is finally enjoined Grace shall at Grace s option (i) procure for Buyer the right to use or resell the goods previously delivered, (ii) replace such goods with equivalent noninfringing goods, (iii) modify them so they become noninfringing but equivalent, or (iv) refund the purchase price (less a reasonable allowance for use, damage and obsolescence). Grace makes no warranty against patent infringement resulting from the manufacture, use or sale of the goods if made to Buyer s specifications or from use of the goods in combination with other matter or in the operation of any process, and if a claim, suit or action is based thereon Buyer shall defend, indemnify and save harmless Grace therefrom.

(c) Grace warrants to Buyer that it will convey goods sold hereunder. Grace s liability and Buyer s remedy under this warranty are limited to the removal of any title defect or, at the election of Grace, to the replacement of the goods or any part thereof which are defective in title; provided, however, that the rights and remedies of the parties with respect to patent infringement shall be limited to the provisions of paragraph (b) above.

THE FOREGOING WARRANTIES ARE EXCLUSIVE AND ARE GIVEN AND ACCEPTED IN LIEU OF ANY AND ALL OTHER WARRANTIES, EXPRESS OR IMPLIED, INCLUDING, WITHOUT LIMITATION, THE IMPLIED WARRANTY OF MERCHANTABILITY AND THE IMPLIED WARRANTY OF FITNESS FOR A PARTICULAR PURPOSE. THE REMEDIES OF BUYER FOR ANY BREACH OF WARRANTY SHALL BE LIMITED TO THOSE PROVIDED HEREIN AND FOR DELAY OR NONDELIVERY WHICH IS NOT EXCUSABLE TO THE PURCHASE PRICE OF THE GOODS IN RESPECT OF WHICH THE DELAY OR NONDELIVERY IS CLAIMED TO THE EXCLUSION OF ANY AND ALL OTHER REMEDIES INCLUDING, WITHOUT LIMITATION, INCIDENTAL OR CONSEQUENTIAL DAMAGES. NO AGREEMENT VARYING OR EXTENDING THE FOREGOING WARRANTIES, REMEDIES OR THIS LIMITATION WILL BE BINDING UPON GRACE UNLESS IN WRITING, SIGNED BY DULY AUTHORIZED OFFICER OF GRACE.

5. Prices, Credit and Payment.

(a) Buyer shall pay for goods, according to the terms of payment as specified on the face hereof or these terms specifically quoted to Buyer in writing. Pro rata payments shall become due as deliveries are made. Prices are subject to change without notice; however, on orders accepted for shipment within thirty (30) days, prices in effect at the time of acceptance will apply unless shipment is delayed beyond thirty (30) days, in which event prices in effect at the time of shipment will apply.

(b) If Buyer shall fail to fulfill the terms of payment, or if Grace at any time shall have any doubt as to Buyer s financial responsibility, Grace without liability to Buyer may decline to make further shipments except against cash or satisfactory security.

(c) If Grace is prevented from revising prices or from continuing any price already in effect by any action of government or by compliance with any request of government, Grace may cancel this contract or any undelivered portion thereof without liability to Buyer upon written notice of such termination to Buyer.

6. Taxes, Duties and Expenses. In the absence of satisfactory evidence in exemption supplied to Grace by Buyer, Buyer shall pay in addition to the price of the goods all taxes, duties, excises or other charges for which Grace may be responsible for collection or payment to any government (national, state, or local) upon, measure, by or relating to the importation, exportation, production, or any phase or part of the production, storage, sale, transportation and/or use of the goods identified on the face hereof.

7. Force Majeure.

(a) Buyer acknowledges that the goods called for hereunder are to be specially manufactured by Grace to fulfill this contract and delivery dates are based on the assumption that there will be no delay due to causes beyond the reasonable control of Grace.

(b) Grace shall not be charged with any liability for delay or non-delivery when due to delays of suppliers, production problems, acts of God or the public enemy compliance with any applicable foreign or domestic court order or governmental regulation or order or request whether or not it proves to be invalid, fire, riot, labor disputes, unusually severe weather, or any other cause beyond the reasonable control of Grace. During the period when deliveries are affected by the matters identified in this paragraph Grace may omit delivery during the period of continuance of such circumstances and the contract quantity shall be reduced by the quantity so omitted but this contract shall remain otherwise in effect. Grace shall endeavor to allocate any available goods among all buyers including its own divisions, departments and affiliates in such manner as it considers fair.

8. Assignment and Nonwaiver.

(a) This contract is not assignable or transferable by Buyer whether voluntary or by operation of law in whole or in part, without the prior written consent of Grace.

(b) Grace s failure to insist upon strict performance of any provision hereof shall be deemed to be a waiver of Grace s rights or remedies or a waiver by Grace of any subsequent default by Buyer in the performance of or compliance with any terms hereof.

9. Separate Contract. Each delivery shall stand as and may be recovered for as a separate and independent contract. If Buyer fails to fulfill the terms of order, purchase or payment under this or any other contract with Grace, Grace without prejudice to other lawful remedies may at its option defer further shipments hereunder until such default is made good, treat such default as a breach of this entire contract or terminate this contract.

10. Compliance with Fair Labor Standards Act. Grace hereby certifies that all goods sold hereunder which are produced or manufactured in the United States of America are produced in compliance with Sections 6, 7, or 12 of the Fair Labor Standards Act of 1938, as amended (29 U.S. Code 201-219) or of any order of the Administrator issued under Section 14 of said Act. All requirements as to the certificate contemplated in the October 26, 1944 amendment to the Fair Labor Standards Act of 1938 shall be considered as satisfied by this certification.

11. Royalties, Miscellaneous. The purchase of equipment from Grace confers no license, express or implied, under any patent. When goods identified on the face hereof include goods suitable for use according to Grace s patents, a royalty amount obtainable upon request is included in the purchase price. Goods identified on the face hereof may vary according to Grace s established limits, sizes and tolerances or effect at the time of delivery in respect of such goods. **ANY ADVICE FURNISHED BUYER CONCERNING THE USE OF THE GOODS SHALL REPRESENT GRACE S BEST JUDGEMENT IN THE CIRCUMSTANCES BUT IS NOT TO BE DEEMED TO BE BINDING UPON BUYER S SOLE RISK.**

12. Entire Contract and Construction.

(a) The contract between Buyer and Grace in respect of the goods identified on the face hereof consists in its entirety of the terms and conditions appearing on the face and back of this document in lieu of all others, and supercedes all previous communications, representations or agreements, either oral or written, between the parties hereto with respect to the subject matter hereof. No modification shall be effected by the acknowledgement or acceptance of Buyer s purchase order forms or other documents containing terms or conditions different from or in addition to those contained herein.

(b) Acceptance or use by Buyer of any goods delivered hereunder shall be an acceptance of these as the only terms and conditions applying to the purchase and sale of said goods unless other terms and conditions are agreed to in writing signed by both parties specifically referring to this contract.

(c) This contract shall be interpreted in accordance with and the construction thereof shall be governed by the laws of the Commonwealth of Massachusetts. Captions as used in these terms and conditions are for convenience of reference only and shall not be deemed or construed as in any way limiting or extending the languages of the provisions to which such captions may refer.

ARCHITECTURAL FACADES

The Ornamental PreCast ▲ Stone Company



ADMIXTURE

www.architecturalfacades.com

600 East Luchessa Avenue, Gilroy, California 95020-7068 • PH 800-346-0826 • FX 408-846-8944

Grace Construction Products

W.R. Grace & Co. - Conn.
293 Wright Brothers Avenue
Livermore, CA 94550

T 925-443-9700
www.grc.construction.com

11/4/2008

Nelly Kaleva
Architectural Facades
600e. Luchessa Ave.
Gilroy, California 95020

Project Name: General
Product Selected: ADVA® Cast 500

GRACE

This is to certify that the ADVA Cast 500, a High Range Water Reducer, as manufactured and supplied by Grace Construction Products, W.R. Grace & Co. - Conn., is formulated to comply with the Specifications for Chemical Admixtures for Concrete, ASTM: C494, Type F, AASHTO: M194, Type F.

ADVA Cast 500 does not contain calcium chloride or chloride containing compounds as a functional ingredient. Chloride ions may be present in trace amounts contributed from the process water used in manufacturing.

The foregoing is in addition to and not in substitution for our standard Conditions of Sale attached.



Mike Gardner
Western Region Technical Services Manager

CONDITIONS

All orders are accepted and all sales are made subject only to the provisions of the written contract between us under which the order is placed, or if no such contract exists, subject only to the terms on the face hereof and to the following provisions.

1. Delivery and Freight: Risk of Loss. Title to and all risk of loss of all goods sold hereunder shall pass to Buyer upon delivery to W. R. Grace & Co. (Grace) to an agent of the Buyer including a common carrier, notwithstanding and payment or allowance of freight by Grace. If Grace pays freight Grace shall have the right to select the carrier, routing and means of transportation, provided that Buyer may make an alternate selection and pay Grace's additional costs, if any.

2. Freight, Weights and Orders.

(a) Whenever Grace is to pay freight Grace shall have the right initially to designate routing and means of transportation. If Buyer requires a more expensive routing and/or means of transportation Buyer shall reimburse Grace for any extra cost involved. **GRACE SHALL NOT BE LIABLE FOR ANY DELAY IN TRANSPORTATION HOWEVER OCCASIONED.**

(b) Grace's invoice weights, volumes, sizes, and tares shall be treated as prima facie correct except that in case of bulk shipments by carload, tank car or otherwise carriers' weights shall be accepted as conclusive.

(c) Buyer's orders are not binding upon Grace until accepted in writing by an authorized employee at Grace's office.

3. Examination, Suitability and Claims. Buyer shall examine and test each shipment of goods promptly upon delivery to Buyer and before any part of the goods has been changed from its original condition and Buyer hereby waives all claims for any cause after any part of the goods has been treated, processed or changed in any manner (except for reasonable test quantities). Buyer assumes sole responsibility for determining whether the goods are suitable for their contemplated use (whether or not such use is known to Grace). Buyer waives all claims of which Grace is not notified in writing within thirty (30) days after delivery of the goods or in respect of goods disposed of or returned without Grace's consent.

4. Warranties, Remedies and Limitations.

(a) Grace warrants to Buyer that at the time of delivery the goods sold hereunder will conform substantially to the description on the face hereof. Grace's liability and Buyer's remedy under this warranty are limited in Grace's discretion to replacement of goods returned to Grace which are shown to Grace's reasonable satisfaction to have been nonconforming or to refund of the purchase price, or, if not paid, to a credit in the amount of the purchase price. Transportation charges for the return of nonconforming goods to Grace and the risk of loss thereof will be borne by Grace only if returned in accordance with written instructions from Grace.

(b) Grace warrants that the goods will not in and of themselves infringe any patent of the United States or Canada. Grace's liability under this warranty is conditioned upon Buyer's giving prompt written notice of any claim of patent infringement made against Buyer, all information available to Buyer in respect of the claim, and Buyer's granting Grace exclusive control of its settlement and/or litigation. Grace may discontinue without liability delivery of the goods if in Grace's opinion their manufacture, sale or use would constitute patent infringement. If the use or resale of the goods is finally enjoined Grace shall at Grace's option (i) procure for Buyer the right to use or resell the goods previously delivered, (ii) replace such goods with equivalent noninfringing goods, (iii) modify them so they become noninfringing but equivalent, or (iv) refund the purchase price (less a reasonable allowance for use, damage and obsolescence). Grace makes no warranty against patent infringement resulting from the manufacture, use or sale of the goods if made to Buyer's specifications or from use of the goods in combination with other matter or in the operation of any process, and if a claim, suit or action is based thereon Buyer shall defend, indemnify and save harmless Grace therefrom.

(c) Grace warrants to Buyer that it will convey goods sold hereunder. Grace's liability and Buyer's remedy under this warranty are limited to the removal of any title defect or, at the election of Grace, to the replacement of the goods or any part thereof which are defective in title; provided, however, that the rights and remedies of the parties with respect to patent infringement shall be limited to the provisions of paragraph (b) above.

THE FOREGOING WARRANTIES ARE EXCLUSIVE AND ARE GIVEN AND ACCEPTED IN LIEU OF ANY AND ALL OTHER WARRANTIES, EXPRESS OR IMPLIED, INCLUDING, WITHOUT LIMITATION, THE IMPLIED WARRANTY OF MERCHANTABILITY AND THE IMPLIED WARRANTY OF FITNESS FOR A PARTICULAR PURPOSE. THE REMEDIES OF BUYER FOR ANY BREACH OF WARRANTY SHALL BE LIMITED TO THOSE PROVIDED HEREIN AND FOR DELAY OR NONDELIVERY WHICH IS NOT EXCUSABLE TO THE PURCHASE PRICE OF THE GOODS IN RESPECT OF WHICH THE DELAY OR NONDELIVERY IS CLAIMED TO THE EXCLUSION OF ANY AND ALL OTHER REMEDIES INCLUDING, WITHOUT LIMITATION, INCIDENTAL OR CONSEQUENTIAL DAMAGES, NO AGREEMENT VARYING OR EXTENDING THE FOREGOING WARRANTIES, REMEDIES OR THIS LIMITATION WILL BE BINDING UPON GRACE UNLESS IN WRITING, SIGNED BY DULY AUTHORIZED OFFICER OF GRACE.

5. Prices, Credit and Payment.

(a) Buyer shall pay for goods, according to the terms of payment as specified on the face hereof or those terms specifically quoted to Buyer in writing. Pro rata payments shall become due as deliveries are made. Prices are subject to change without notice; however, on orders accepted for shipment within thirty (30) days, prices in effect at the time of acceptance will apply unless shipment is delayed beyond thirty (30) days, in which event prices in effect at the time of shipment will apply.

(b) If Buyer shall fail to fulfill the terms of payment, or if Grace at any time shall have any doubt as to Buyer's financial responsibility, Grace without liability to Buyer may decline to make further shipments except against cash or satisfactory security.

(c) If Grace is prevented from revising prices or from continuing any prices already in effect by any action of government or by compliance with any request of government, Grace may cancel this contract or any undelivered portion thereof without liability to Buyer upon written notice of such termination to Buyer.

6. Taxes, Duties and Excises. In the absence of satisfactory evidence of exemption supplied to Grace by Buyer, Buyer shall pay in addition to the price of the goods all taxes, duties, excises or other charges for which Grace may be responsible for collection or payment to any government (national, state, or local) upon measures by or relating to the importation, exportation, production, or any phase or part of the production, storage, sale, transportation and/or use of the goods identified on the face hereof.

7. Force Majeure.

(a) Buyer acknowledges that the goods called for hereunder are to be specifically manufactured by Grace in fulfillment of this contract and delivery dates are based on the assumption that there will be no delay due to causes beyond the reasonable control of Grace.

(b) Grace shall not be charged with any liability for delay or nondelivery when due to delays of suppliers, production problems, acts of God or the public enemy, compliance with any applicable foreign or domestic court order or governmental regulation, order or request whether or not it proves to be invalid, fires, riots, labor disputes, unusually severe weather, or any other cause beyond the reasonable control of Grace. During the period when deliveries are affected by the matters mentioned in this paragraph, Grace may omit delivery during the period of continuance of such circumstances and the contract quantity shall be reduced by the quantity so omitted, but this contract shall remain otherwise in effect. Grace shall endeavor to locate any available goods among all buyers including its own divisions, departments and affiliates in such manner as it considers fair.

8. Assignment and Nonwaiver.

(a) This contract is not assignable or transferable by Buyer whether voluntary or by operation of law in whole or in part, without the prior written consent of Grace.

(b) Grace's failure to insist upon strict performance of any provision hereof shall be deemed to be a waiver of Grace's rights or remedies or a waiver by Grace of any subsequent default by Buyer in the performance of or compliance with any terms hereof.

9. Separate Contract. Each delivery shall stand and may be recovered for as a separate and independent contract. If Buyer fails to fulfill the terms of order, purchase, or payment under this or any other contract with Grace, Grace without prejudice to other lawful remedies may at its option defer further shipments hereunder until such default is made good, treat such default as a breach of this entire contract or terminate this contract.

10. Compliance with Fair Labor Standards Act. Grace hereby certifies that all goods sold hereunder which are produced or manufactured in the United States or America are produced in compliance with Sections 6, 7, or 12 of the Fair Labor Standards Act of 1938, as amended (29 U.S. Code 211-219), or of any order of the Administrator issued under Section 14 of said Act. All requirements as to the certified compliance in the October 26, 1949 amendment to the Fair Labor Standards Act of 1938 shall be considered as satisfied by this certification.

11. Royalties: Miscellaneous. The purchase of equipment from Grace confers no license, express or implied, under any patent. When goods identified on the face hereof include goods suitable for use according to Grace's patents, a royalty (amount obtainable upon request) is included in the purchase price. Goods identified on the face hereof may vary according to Grace's established limits, sizes and to enhance in effect at the time of delivery in respect of such goods. **ANY ADVICE FURNISHED BUYER CONCERNING THE USE OF THE GOODS SHALL REPRESENT GRACE'S BEST JUDGEMENT IN THE CIRCUMSTANCES BUT IS ACTED UPON AT BUYER'S SOLE RISK.**

12. Entire Contract and Construction.

(a) The contract between Buyer and Grace in respect of the goods identified on the face hereof consists in its entirety of the terms and conditions appearing on the face and back of this document in lieu of all other, and supersedes all previous communications, representations or agreements, either oral or written, between the parties hereto with respect to the subject matter hereof. No modification shall be effected by the acknowledgement or acceptance of Buyer's purchase order form or other documents containing terms or conditions different from or in addition to those contained herein.

(b) Acceptance or use by Buyer of any goods delivered hereunder shall be an acceptance of these as the only terms and conditions applying to the purchase and sale of said goods unless other terms and conditions be agreed to in writing signed by both parties specifically referring to this contract.

(c) This contract shall be interpreted in accordance with and the construction thereof shall be governed by the laws of the Commonwealth of Massachusetts. Captions as used in these terms and conditions are for convenience of reference only and shall not be deemed or construed as in any way limiting or extending the language of the provisions to which such captions may refer.

4. Contemporary design of alterations is permitted, provided that such alterations do not destroy significant exterior architectural material and that such design is compatible with the size, scale, color, material and character of the building and its surroundings;

There will be no design changes

5. The degree to which distinctive features need be retained may be less when the alteration is to exterior elements not constituting a part of a principal facade or when it is an alteration of the ground-floor frontage in order to adapt the space for ground-floor uses;

H/A

6. In the case of Significant Buildings - Category I, any additions to height of the building (including addition of mechanical equipment) shall be limited to one story above the height of the existing roof, shall be compatible with the scale and character of the building, and shall in no event cover more than 75 percent of the roof area;

H/A THIS CATEGORY I but no height addition

7. In the case of Significant Buildings - Category II, a new structure or addition, including one of greater height than the existing building, may be permitted on that portion of the lot not restricted in Appendix B even if such structure or addition will be visible when viewing the principal facades at ground level, provided that the structure or addition does not affect the appearance of the retained portion as a separate structure when so viewing the principal facades and is compatible in form and design with the retained portion. Alteration of the retained portion of the building is permitted as provided in Paragraphs (1) through (6) of this Subsection (b);

H/A. CATEGORY I

Application for Permit to Alter	
CASE NUMBER:	
<small>Please Print. Use only.</small>	

Findings of Compliance with General Preservation Standards

In reviewing applications for Permits to Alter the Historic Preservation Commission, the Historic Preservation Officer, Board of Permit Appeals, the Planning Department and the Planning Commission shall be governed by *The Secretary of the Interior's Standards for the Treatment of Historic Properties* as an additional evaluative standard in the review of applications for major alteration permits. The Standards are contained in the Preserving the Past section of the Downtown Plan, a component of the San Francisco General Plan. Please respond to each statement completely (Note: Attach continuation sheets, if necessary). Give reasons as to *how* and *why* the project meets the ten Standards rather than merely concluding that it does so. IF A GIVEN REQUIREMENT DOES NOT APPLY TO YOUR PROJECT, EXPLAIN WHY IT DOES NOT.

1. The property will be used as it was historically or be given a new use that requires minimal change to its distinctive materials, features, spaces, and spatial relationships;

Facade is only altered
 Use of this property will not change.
 It was originally commercial. Renewed so
 until recently.

2. The historic character of a property will be retained and preserved. The removal of distinctive materials or alteration of features, spaces, and spatial relationships that characterize the property will be avoided;

All materials removed will be replaced
 with exact features in GPRC

3. Each property will be recognized as a physical record of its time, place and use. Changes that create a false sense of historical development, such as adding conjectural features or elements from other historic properties, will not be undertaken;

There will be no adding of
 conjectural features

4. Changes to a property that have acquired historic significance in their own right will be retained and preserved;

There will be no change to the historic significance.

5. Distinctive materials, features, finishes, and construction techniques or examples of fine craftsmanship that characterize a property will be preserved;

Such architectural features will be replaced in GRC.

6. Deteriorated historic features will be repaired rather than replaced. Where the severity of deterioration requires replacement of a distinctive feature, the new feature will match the old in design, color, texture, and, where possible, materials. Replacement of missing features will be substantiated by documentary and physical evidence;

Replacement features will match the old in design, color, texture.
Molds are taken for original samples

7. Chemical or physical treatments, if appropriate, will be undertaken using the gentlest means possible. Treatments that cause damage to historic materials will not be used;

All features that are not removed will be cleaned with detergent and gentle scrubbing.

Application for Permit to Alter	
CASE NUMBER: <small>For Staff Use only</small>	

8. Archeological resources will be protected and preserved in place. If such resources must be disturbed, mitigation measures will be undertaken;

There are no Archeological findings at this time.

9. New additions, exterior alterations, or related new construction will not destroy historic materials, features, and spatial relationships that characterize the property. The new work shall be differentiated from the old and will be compatible with the historic materials, features, size, scale and proportion, and massing to protect the integrity of the property and its environment;

The Repair work represents an entire feature of the building. It is differentiated in that respect and is compatible with historic materials since replacement design will not be changed.

10. New additions and adjacent or related new construction will be undertaken in such a manner that, if removed in the future, the essential form and integrity of the historic property and its environment would not be impaired;

There are no new additions, adjacent or related new construction being installed here in this application.

PLEASE NOTE: For all applications pertaining to buildings located within Conservation Districts, the proposed work must comply with all applicable standards and guidelines set forth in Section 6 and 7 of the Appendix which describes the District, in addition to the applicable standards and requirements set forth in Section 1111.5. In the event of any conflict between the standards of Section 1111.5 and the standards contained within the Appendix which describes the District, the more protective shall prevail.

Estimated Construction Costs

TYPE OF APPLICATION: <u>Repair</u>	
OCCUPANCY CLASSIFICATION: <u>M-B</u>	
BUILDING TYPE: <u>MASONRY</u>	
TOTAL GROSS SQUARE FEET OF CONSTRUCTION: <u>CORNICE 18' HIGH X 120' Length</u>	BY PROPOSED USES:
ESTIMATED CONSTRUCTION COST: <u>\$ 1,000,000.00</u>	
ESTIMATE PREPARED BY: <u>Thomas A Lewis</u>	
FEE ESTABLISHED:	

Applicant's Affidavit

Under penalty of perjury the following declarations are made:

- a: The undersigned is the owner or authorized agent of the owner of this property.
- b: The information presented is true and correct to the best of my knowledge.
- c: The other information or applications may be required.

Signature:  Date: 10/21/10

Print name, and indicate whether owner, or authorized agent:

THOMAS A LEWIS AGENT
Owner / Authorized Agent (circle one)

Application for Permit to Alter	
CASE NUMBER: <small>For Staff Use only</small>	

APPLICATION FOR Permit to Alter

1. Owner/Applicant Information

PROPERTY OWNER'S NAME: 211 Sutter St. PARTNERS LLC	
PROPERTY OWNER'S ADDRESS: 211 Sutter St, 8th Floor S.F., CA. 94108	TELEPHONE: (415) 399-9995
	EMAIL: amicynth@gmail.com
PROPERTY OWNER'S NAME: Same as Above <input checked="" type="checkbox"/>	
PROPERTY OWNER'S ADDRESS:	TELEPHONE: ()
	EMAIL:
CONTACT FOR PROJECT INFORMATION: Thomas Lewis	
Same as Above <input checked="" type="checkbox"/>	
PROPERTY OWNER'S ADDRESS:	TELEPHONE: ()
	EMAIL:

2. Location and Classification

STREET ADDRESS OF PROJECT: 211 Sutter St. S.F.		ZIP CODE: 94108
CROSS STREETS: Kearny		
ASSESSORS BLOCK/LOT: 0293 01	LOT DIMENSIONS: 50x70	LOT AREA (SQ FT): 3500 [±]
ZONING DISTRICT: C-3-0	HEIGHT/BULK DISTRICT: 80-130-F	
ARTICLE 11 CLASSIFICATION: Category I	CONSERVATION DISTRICT: Kearny-Market-Mason-Sutter	

3. Project Description

Please check all that apply

New Construction Addition(s) Alterations Demolition Other

Additions to Building: Rear Front Height Side Yard

Building Permit Application No. 201003269573 Date Filed: 4/9/2010

Application for Permit to Alter

CASE NUMBER:
For Staff Use only

4. Project Summary Table

If you are not sure of the eventual size of the project, provide the maximum estimates.

GROSS SQUARE FOOTAGE (GSF)	EXISTING USES	EXISTING USES TO BE RETAINED	NET NEW CONSTRUCTION AND/OR ADDITION	PROJECT TOTALS
Residential				
Retail				
Office				
Industrial				
PDR Production, Distribution, & Repair				
Parking				
Other (Specify Use)				
Total GSF				
PROJECT FEATURES	EXISTING USES	EXISTING USES TO BE RETAINED	NET NEW CONSTRUCTION AND/OR ADDITION	PROJECT TOTALS
Dwelling Units				
Hotel Rooms				
Parking Spaces				
Loading Spaces				
Number of Buildings				
Height of Building(s)				
Number of Stories				

Please provide a narrative project description, and describe any additional project features that are not included in this table:

Remove terra cotta at 9th, 10th floors to expose water damaged structural steel. Most of terra cotta is damaged from steel corrosion. Replace damaged steel columns, beams, and c-channels. Install GFRP replicas of all terra cotta elements to match existing in form and color.

Application for Permit to Alter	
CASE NUMBER:	
<small>For Staff Use only</small>	

Permit to Alter Findings

In reviewing applications for Permits to Alter, the Historic Preservation Commission, the Historic Preservation Officer, Board of Permit Appeals, and the Planning Commission shall be governed by the following requirements set forth in Planning Code Section 1111.5. Please describe below how the project is consistent with each requirement (Note: Attach continuation sheets, if necessary). Each requirement must have a response. IF A GIVEN REQUIREMENT DOES NOT APPLY TO YOUR PROJECT, EXPLAIN WHY IT DOES NOT.

1. The distinguishing original qualities or character of the building may not be damaged or destroyed. Any distinctive architectural feature which affects the overall appearance of the building shall not be removed or altered unless it is the only feasible means to protect the public safety;

Public safety is at risk without removal of architectural features.

2. The integrity of distinctive stylistic features or examples of skilled craftsmanship that characterize a building shall be preserved.;

The integrity of distinctive features and skilled craftsmanship is being preserved by installation of exact replicas in GFRC

3. Distinctive architectural features which are to be retained pursuant to Paragraph (1) but which are deteriorated shall be repaired rather than replaced, whenever possible. In the event replacement is necessary, the new material shall match the material being replaced in composition, design, color, texture and other visual qualities. Repair or replacement of missing architectural features shall be based on accurate duplication of features, substantiated by historic, physical or pictorial evidence, if available, rather than on conjectural designs or the availability of different architectural elements from other buildings or structures. Replacement of nonvisible structural elements need not match or duplicate the material being replaced.;

The new material will match in design, color, texture and all other visual qualities. Direct molds of original elements are being used. GFRC is the composition.





























CLAY & C



Kary 1

Sutter 1

7



2





























34 1/2
35 1/2





SPAC



KEARNY SIDE

KEARNY SIDE

KEARNY SIDE

KEARNY SIDE

KEARNY SIDE

KEARNY SIDE

KEARNY SIDE

KEARNY SIDE

6371 FBI

6371 FBI





























16 Preservation Briefs

Technical Preservation Services

National Park Service
U.S. Department of the Interior

The Use of Substitute Materials on Historic Building Exteriors

Sharon C. Park, AIA

- » [Introduction](#)
- » [Historical Use of Substitute Materials](#)
- » [When to Consider Using Substitute Materials](#)
- » [Cautions and Concerns](#)
- » [Choosing an Appropriate Substitute Material](#)
- » [Pros and Cons of Various Substitute Materials](#)
- » [Summary](#)
- » [Further Reading](#)



A NOTE TO OUR USERS: The web versions of the **Preservation Briefs** differ somewhat from the printed versions. Many illustrations are new, captions are simplified, illustrations are typically in color rather than black and white, and some complex charts have been omitted.

The Secretary of the Interior's Standards for Rehabilitation require that "deteriorated architectural features be repaired rather than replaced, wherever possible. In the event that replacement is necessary, the new material should match the material being replaced in composition, design, color, texture, and other visual properties." Substitute materials should be used only on a limited basis and only when they will match the appearance and general properties of the historic material and will not damage the historic resource.

Introduction

When deteriorated, damaged, or lost features of a historic building need repair or replacement, it is almost always best to use historic materials. In limited circumstances substitute materials that imitate historic materials may be used if the appearance and properties of the historic materials can be matched closely and no damage to the remaining historic fabric will result.

Great care must be taken if substitute materials are used on the exteriors of historic buildings. Ultraviolet light, moisture penetration behind joints, and stresses caused by changing temperatures can greatly impair the performance of substitute materials over time. Only after consideration of all options, in consultation with qualified professionals, experienced fabricators and contractors, and development of carefully written specifications should this work be undertaken.



In the reconstruction of the clock tower at Independence Hall, the substitute materials used were cast stone and wood with fiberglass and polyester bronze ornamentation. Photo: NPS files.

The practice of using substitute materials in architecture is not new, yet it continues to pose practical problems and to raise philosophical questions. On the practical level the inappropriate choice or improper installation of substitute materials can cause a radical change in a building's appearance and can cause extensive physical damage over time. On the more philosophical level, the wholesale use of substitute materials can raise questions concerning the integrity of historic buildings largely comprised of new materials. In both cases the integrity of the historic resource can be destroyed.

Some preservationists advocate that substitute materials should be avoided in all but the most limited cases. The fact is, however, that substitute materials are being used more frequently than ever in preservation projects, and in many cases with positive results. They can be cost-effective, can permit the accurate visual duplication of historic materials, and last a reasonable time. Growing evidence indicates that with proper planning, careful specifications and supervision, substitute materials can be used successfully in the process of restoring the visual appearance of historic resources.

This Brief provides general guidance on the use of substitute materials on the exteriors of historic buildings. While substitute materials are frequently used on interiors, these applications are not subject to weathering and moisture penetration, and will not be discussed in this Brief. Given the general nature of this publication, specifications for substitute materials are not provided. The guidance provided should not be used in place of consultations with qualified professionals. This Brief includes a discussion of when to use substitute materials, cautions regarding their expected performance, and descriptions of several substitute materials, their advantages and disadvantages. This review of materials is by no means comprehensive, and attitudes and findings will change as technology develops.

Historical Use of Substitute Materials

The tradition of using cheaper and more common materials in imitation of more expensive and less available materials is a long one. George Washington, for example, used wood painted with sand-impregnated paint at Mount Vernon to imitate cut ashlar stone. This technique along with scoring stucco into block patterns was fairly common in colonial America to imitate stone.

Molded or cast masonry substitutes, such as dry-tamp cast stone and poured concrete, became popular in place of quarried stone during the 19th century. These masonry units were fabricated locally, avoiding expensive quarrying and shipping costs, and were versatile in representing either ornately carved blocks, plain wall stones or rough cut textured surfaces. The end result depended on the type of patterned or textured mold used and was particularly popular in conjunction with mail order houses. Later, panels of cementitious permastone or formstone and less expensive asphalt and sheet metal panels were used to imitate brick or stone.

Metal (cast, stamped, or brake-formed) was used for storefronts, canopies, railings, and other features, such as galvanized metal cornices substituting for wood or stone, stamped metal panels for Spanish clay roofing tiles, and cast-iron column capitals and even entire building fronts in imitation of building stone.

Terra-cotta, a molded fired clay product, was itself a substitute material and was very popular in the late 19th and early 20th centuries. It simulated the appearance of intricately carved stonework, which was expensive and time-consuming to produce. Terra cotta could be glazed to imitate a variety of natural stones, from brownstones to limestones, or could be colored for a polychrome effect.

Nineteenth century technology made a variety of materials readily available that not only were able to imitate more expensive materials but were also cheaper to fabricate and easier to use. Throughout the century, imitative materials continued to evolve. For example, ornamental window hoods were originally made of wood or carved stone. In an effort to find a cheaper substitute for carved stone and to speed fabrication time, cast stone, an early form of concrete, or cast-iron hoods often replaced stone. Toward the end of the century, even less expensive sheet metal hoods, imitating stone, also came into widespread use. All of these materials, stone, cast stone, cast iron, and various pressed metals were in production at the same time and were selected on the basis on the basis of the availability of materials and local craftsmanship, as well as durability and cost. The criteria for selection today are not much different.

Many of the materials used historically to imitate other materials are still available. These are often referred to as the traditional materials: wood, cast stone, concrete, terra cotta and cast metals. In the last few decades, however, and partly as a result of the historic preservation movement, new families of synthetic materials, such as fiberglass, acrylic polymers, and epoxy resins, have been developed and are being used as substitute materials in construction. In some respects these newer products (often referred to as high tech materials) show great promise; in others, they are less satisfactory, since they are often difficult to integrate physically with the porous historic materials and may be too new to have established solid performance records.



Substitute materials need to be located with care to avoid damage. The fiberglass column base has chipped, whereas the historic cast iron would have remained sound. Photo: NPS files.

When to Consider Using Substitute Materials in Preservation Projects

Because the overzealous use of substitute materials can greatly impair the historic character of a historic structure, all preservation options should be explored thoroughly before substitute materials are used. It is important to remember that the purpose of repairing damaged features and of replacing lost and irreparably damaged ones is both to match visually what was there and to cause no further deterioration. For these reasons it is not appropriate to cover up historic materials with synthetic materials that will alter the appearance, proportions and details of a historic building and that will conceal future deterioration.

Some materials have been used successfully for the repair of damaged features such as epoxies for wood infilling, cementitious patching for sandstone repairs, or plastic stone for masonry repairs. Repairs are preferable to replacement whether or not the repairs

are in kind or with a synthetic substitute material.

In general, four circumstances warrant the consideration of substitute materials: 1) the unavailability of historic materials; 2) the unavailability of skilled craftsmen; 3) inherent flaws in the original materials; and 4) code-required changes (which in many cases can be extremely destructive of historic resources).

Cost may or may not be a determining factor in considering the use of substitute materials. Depending on the area of the country, the amount of material needed, and the projected life of less durable substitute materials, it may be cheaper in the long run to use the original material, even though it may be harder to find.



The core of a deteriorated wood outrigger was first drilled out. Photos (left and right): Courtesy, Harrison Goodall.



An inert material was injected into the hollow outrigger, permitting the outer wood to be retained and preserved.

Due to many early failures of substitute materials, some preservationist are looking abroad to find materials (especially stone) that match the historic materials in an effort to restore historic buildings accurately and to avoid many of the uncertainties that come with the use of substitute materials.

1. The unavailability of the historic material.

The most common reason for considering substitute materials is the difficulty in finding a good match for the historic material (particularly a problem for masonry materials where the color and texture are derived from the material itself). This may be due to the actual unavailability of the material or to protracted delivery dates. For example, the local quarry that supplied the sandstone for a building may no longer be in operation. All efforts should be made to locate another quarry that could supply a satisfactory match. If this approach fails, substitute materials such as dry-tamp cast stone or textured precast concrete may be a suitable substitute if care is taken to ensure that the detail, color and texture of the original stone are matched. In some cases, it may be possible to use a sand-impregnated paint on wood as a replacement section, achieved using readily available traditional materials, conventional tools and work skills. Simple solutions should not be overlooked.

2. The unavailability of historic craft techniques and lack of skilled artisans.

These two reasons complicate any preservation or rehabilitation project. This is particularly true for intricate ornamental work, such as carved wood, carved stone, wrought iron, cast iron, or molded terra cotta. However, a number of stone and wood cutters now employ sophisticated carving machines, some even computerized. It is also possible to cast substitute replacement pieces using aluminum, cast stone, fiberglass, polymer concretes, glass fiber reinforced concretes and terra cotta. Mold making and

casting takes skill and craftsmen who can undertake this work are available. Efforts should always be made, prior to replacement, to seek out artisans who might be able to repair ornamental elements and thereby save the historic features in place.

3. Poor original building materials.

Some historic building materials were of inherently poor quality or their modern counterparts are inferior. In addition, some materials were naturally incompatible with other materials on the building, causing staining or galvanic corrosion. Examples of poor quality materials were the very soft sandstones which eroded quickly. An example of poor quality modern replacement material is the tin coated steel roofing which is much less durable than the historic tin or terne iron which is no longer available. In some cases, more durable natural stones or precast concrete might be available as substitutes for the soft stones and modern terne-coated stainless steel or lead-coated copper might produce a more durable yet visually compatible replacement roofing.



Cast aluminum has been used as a replacement material for cast iron. Photo: NPS files.

4. Code-related changes.

Sometimes referred to as life and safety codes, building codes often require changes to historic buildings. Many cities in earthquake zones, for example, have laws requiring that overhanging masonry parapets and cornices, or freestanding urns or finials be securely re-anchored to new structural frames or be removed completely. In some cases, it may be acceptable to replace these heavy historic elements with light replicas. In other cases, the extent of historic fabric removed may be so great as to diminish the integrity of the resource. This could affect the significance of the structure and jeopardize National Register status. In addition, removal of repairable historic materials could result in loss of Federal tax credits for rehabilitation. Department of the Interior regulations make clear that the Secretary of the Interior's Standards for Rehabilitation take precedence over other regulations and codes in determining whether a project is consistent with the historic character of the building undergoing rehabilitation.

Two secondary reasons for considering the use of substitute materials are their lighter weight and for some materials, a reduced need of maintenance. These reasons can become important if there is a need to keep dead loads to a minimum or if the feature being replaced is relatively inaccessible for routine maintenance.

Cautions and Concerns

In dealing with exterior features and materials, it must be remembered that moisture penetration, ultraviolet degradation, and differing thermal expansion and contraction rates of dissimilar materials make any repair or replacement problematic. To ensure that a repair or replacement will perform well over time, it is critical to understand fully the properties of both the original and the substitute materials, to install replacement materials correctly, to assess their impact on adjacent historic materials, and to have reasonable expectations of future performance.

Many high tech materials are too new to have been tested thoroughly. The differences in vapor permeability between some synthetic materials and the historic materials have in some cases caused unexpected further deterioration. It is therefore difficult to recommend substitute materials if the historic materials are still available. As previously mentioned, consideration should always be given first to using traditional materials and

methods of repair or replacement before accepting unproven techniques, materials or applications.

Substitute materials must meet three basic criteria before being considered: they must be compatible with the historic materials in appearance; their physical properties must be similar to those of the historic materials, or be installed in a manner that tolerates differences; and they must meet certain basic performance expectations over an extended period of time.

Matching the Appearance of the Historic Materials

In order to provide an appearance that is compatible with the historic material, the new material should match the details and craftsmanship of the original as well as the color, surface texture, surface reflectivity and finish of the original material. The closer an element is to the viewer, the more closely the material and craftsmanship must match the original.

Matching the color and surface texture of the historic material with a substitute material is normally difficult. To enhance the chances of a good match, it is advisable to clean a portion of the building where new materials are to be used. If pigments are to be added to the substitute material, a specialist should determine the formulation of the mix, the natural aggregates and the types of pigments to be used. As all exposed material is subject to ultraviolet degradation, if possible, samples of the new materials made during the early planning phases should be tested or allowed to weather over several seasons to test for color stability.

Fabricators should supply a sufficient number of samples to permit onsite comparison of color, texture, detailing, and other critical qualities. In situations where there are subtle variations in color and texture within the original materials, the substitute materials should be similarly varied so that they are not conspicuous by their uniformity.

Substitute materials, notably the masonry ones, may be more water-absorbent than the historic material. If this is visually distracting, it may be appropriate to apply a protective vapor-permeable coating on the substitute material. However, these clear coatings tend to alter the reflectivity of the material, must be reapplied periodically, and may trap salts and moisture, which can in turn produce spalling. For these reasons, they are not recommended for use on historic materials.

Matching the Physical Properties

While substitute materials can closely match the appearance of historic ones, their physical properties may differ greatly. The chemical composition of the material (i.e., presence of acids, alkalines, salts, or metals) should be evaluated to ensure that the replacement materials will be compatible with the historic resource. Special care must therefore be taken to integrate and to anchor the new materials properly. The thermal expansion and contraction coefficients of each adjacent material must be within tolerable limits. The function of joints must be understood and detailed either to eliminate moisture penetration or to allow vapor permeability. Materials that will cause galvanic corrosion or other chemical reactions must be isolated from one another.



A waterproof coating is an inappropriate substitute material to apply to adobe as it seals in moisture and may result in spalling. Photo: NPS files.

To ensure proper attachment, surface preparation is critical. Deteriorated underlying material must be cleaned out. Noncorrosive anchoring devices or fasteners that are designed to carry the new material and to withstand wind, snow and other destructive elements should be used. Properly chosen fasteners allow attached materials to expand and contract at their own rates. Caulking, flexible sealants or expansion joints between the historic material and the substitute material can absorb slight differences of movement. Since physical failures often result from poor anchorage or improper installation techniques, a structural engineer should be a member of any team undertaking major repairs.

Some of the new high tech materials such as epoxies and polymers are much stronger than historic materials and generally impermeable to moisture. These differences can cause serious problems unless the new materials are modified to match the expansion and contraction properties of adjacent historic materials more closely, or unless the new materials are isolated from the historic ones altogether. When stronger or vapor impermeable new materials are used alongside historic ones, stresses from trapped moisture or differing expansion and contraction rates generally hasten deterioration of the weaker historic material. For this reason, a conservative approach to repair or replacement is recommended, one that uses more pliant materials rather than high-strength ones. Since it is almost impossible for substitute materials to match the properties of historic materials perfectly, the new system incorporating new and historic materials should be designed so that if material failures occur, they occur within the new material rather than the historic material.

Performance Expectations

While a substitute material may appear to be acceptable at the time of installation, both its appearance and its performance may deteriorate rapidly. Some materials are so new that industry standards are not available, thus making it difficult to specify quality control in fabrication, or to predict maintenance requirements and long term performance. Where possible, projects involving substitute materials in similar circumstances should be examined. Material specifications outlining stability of color and texture; compressive or tensile strengths if appropriate; the acceptable range of thermal coefficients, and the durability of coatings and finishes should be included in the contract documents. Without these written documents, the owner may be left with little recourse if failure occurs.



The historic cornice was successfully replaced with a fiberglass cornice. Photo: NPS files.

The tight controls necessary to ensure long-term performance extend beyond having written performance standards and selecting materials that have a successful track record. It is important to select qualified fabricators and installers who know what they are doing and who can follow up if repairs are necessary. Installers and contractors unfamiliar with specific substitute materials and how they function in your local environmental conditions should be avoided.

The surfaces of substitute materials may need special care once installed. For example, chemical residues or mold release agents should be removed completely prior to installation, since they attract pollutants and cause the replacement materials to appear dirtier than the adjacent historic materials. Furthermore, substitute materials

may require more frequent cleaning, special cleaning products and protection from impact by hanging window-cleaning scaffolding. Finally, it is critical that the substitute materials be identified as part of the historical record of the building so that proper care and maintenance of all the building materials continue to ensure the life of the historic resource.

Choosing an Appropriate Substitute Material

Once all reasonable options for repair or replacement in kind have been exhausted, the choice among a wide variety of substitute materials currently on the market must be made. The charts at the end of this Brief describe a number of such materials, many of them in the family of modified concretes which are gaining greater use. The charts do not include wood, stamped metal, mineral fiber cement shingles and some other traditional imitative materials, since their properties and performance are better known. Nor do the charts include vinyls or molded urethanes which are sometimes used as cosmetic claddings or as substitutes for wooden millwork. Because millwork is still readily available, it should be replaced in kind.

The charts describe the properties and uses of several materials finding greater use in historic preservation projects, and outline advantages and disadvantages of each. It should not be read as an endorsement of any of these materials, but serves as a reminder that numerous materials must be studied carefully before selecting the appropriate treatment. Included are three predominantly masonry materials (cast stone, precast concrete, and glass fiber reinforced concrete); two predominantly resinous materials (epoxy and glass fiber reinforced polymers also known as fiberglass), and cast aluminum which has been used as a substitute for various metals and woods.

Pros and Cons of Various Substitute Materials

Cast Aluminum

Material: Cast aluminum is a molten aluminum alloy cast in permanent (metal) molds or onetime sand molds which must be adjusted for shrinkage during the curing process. Color is from paint applied to primed aluminum or from a factory finished coating. Small sections can be bolted together to achieve intricate or sculptural details. Unit castings are also available for items such as column plinth blocks.

Application: Cast aluminum can be a substitute for cast iron or other decorative elements. This would include grillwork, roof crestings, cornices, ornamental spandrels, storefront elements, columns, capitals, and column bases and plinth blocks. If not self-supporting, elements are generally screwed or bolted to a structural frame. As a result of galvanic corrosion problems with dissimilar metals, joint details are very important.

Advantages:

- light weight (1/2 of cast iron)
- corrosion-resistant, noncombustible
- intricate castings possible
- easily assembled, good delivery time
- can be prepared for a variety of colors
- long life, durable, less brittle than cast iron

Disadvantages:

- lower structural strength than cast iron
- difficult to prevent galvanic corrosion with other metals
- greater expansion and contraction than cast iron; requires
- gaskets or caulked joints
- difficult to keep paint on aluminum

Checklist:

- Can existing be repaired or replaced in kind?
- How is cast aluminum to be with other metals attached?
- Have full-size details been developed for each piece to be cast?
- How are expansion joints detailed?
- Will there be a galvanic corrosion problem?
-
- Are fabricators/installers experienced?

Cast Stone (dry tamped)

Material: Cast stone is an almost-dry cement, lime and aggregate mixture which is dry-tamped into a mold to produce a dense stone-like unit. Confusion arises in the building industry as many refer to high quality precast concrete as cast stone. In fact, while it is a form of precast concrete, the drytamp fabrication method produces an outer surface resembling a stone surface. The inner core can be either drytamped or poured full of concrete. Reinforcing bars and anchorage devices can be installed during fabrication.

Application: Cast stone is often the most visually similar material as a replacement for unveined deteriorated stone, such as brownstone or sandstone, or terra cotta in imitation of stone. It is used both for surface wall stones and for ornamental features such as window and door surrounds, voussoirs, brackets and hoods. Rubberlike molds can be taken of good stones on site or made up at the factory from shop drawings.

Advantages:

- replicates stone texture with good molds (which can come from extant stone) and fabrication
- expansion/contraction similar to stone
- minimal shrinkage of material
- anchors and reinforcing bars can be built in
- material is fire-rated
- range of color available
- vapor permeable

Disadvantages:

- heavy units may require additional anchorage
- color can fade in sunlight
- may be more absorbent than natural stone
- replacement stones are obvious if too few models and molds are made

Checklist:

- Are the original or similar materials available?
- How are units to be installed and anchored?

- Have performance standards been developed to ensure color stability?
- Have large samples been delivered to site for color, finish and absorption testing?
- Has mortar been matched to adjacent historic mortar to achieve a good color/tooling match?
- Are fabricators/installers experienced?

Glass Fiber Reinforced Concretes (GFRC)

Material: Glass fiber reinforced concretes are lightweight concrete compounds modified with additives and reinforced with glass fibers. They are generally fabricated as thin shelled panels and applied to a separate structural frame or anchorage system. The GFRC is most commonly sprayed into forms although it can be poured. The glass must be alkaline resistant to avoid deteriorating effects caused by the cement mix. The color is derived from the natural aggregates and if necessary a small percentage of added pigments.

Application: Glass fiber reinforced concretes are used in place of features originally made of stone, terra cotta, metal or wood, such as cornices, projecting window and door trims, brackets, finials, or wall murals. As a molded product it can be produced in long sections of repetitive designs or as sculptural elements. Because of its low shrinkage, it can be produced from molds taken directly from the building. It is installed with a separate noncorrosive anchorage system. As a predominantly cementitious material, it is vapor permeable.

Advantages:

- lightweight, easily installed
- good molding ability, crisp detail possible
- weather resistant
- can be left uncoated or else painted
- little shrinkage during fabrication
- molds made directly from historic features
- cements generally breathable
- material is fire-rated

Disadvantages:

- non-loadbearing use only
- generally requires separate anchorage system
- large panels must be reinforced
- color additives may fade with sunlight
- joints must be properly detailed
- may have different absorption rate than adjacent historic material

Checklist:

- Are the original materials and craftsmanship still available?
- Have samples been inspected on the site to ensure detail/texture match?
- Has anchorage system been properly designed?
- Have performance standards been developed?
- Are fabricators/installers experienced?

Precast Concrete

Material: Precast concrete is a wet mix of cement and aggregate poured into molds to create masonry units. Molds can be made from existing good surfaces on the building.

Color is generally integral to the mix as a natural coloration of the sand or aggregate, or as a small percentage of pigment. To avoid unsightly air bubbles that result from the natural curing process, great care must be taken in the initial and longterm vibration of the mix. Because of its weight it is generally used to reproduce individual units of masonry and not thin shell panels.

Application: Precast concrete is generally used in place of masonry materials such as stone or terra cotta. It is used both for flat wall surfaces and for textured or ornamental elements. This includes wall stones, window and door surrounds, stair treads, paving pieces, parapets, urns, balusters and other decorative elements. It differs from cast stone in that the surface is more dependent on the textured mold than the hand tamping method of fabrication.

Advantages:

- easily fabricated, takes shape well
- rubber molds can be made from building stones
- minimal shrinkage of material
- can be load bearing or anchorage can be cast in
- expansion/contraction similar to stone
- material is fire-rated
- range of color and aggregate available
- vapor permeable

Disadvantages:

- may be more moisture absorbent than stone although coatings may be applied
- color fades in sunlight
- small air bubbles may disfigure units
- replacement stones are conspicuous if too few models and molds are made

Checklist:

- Is the historic material still available?
- What are the structural/anchorage requirements?
- Have samples been matched for color/texture/absorption? Have shop drawings been made for each shape?
- Are there performance standards?
- Has mortar been matched to adjacent historic mortar to achieve good color/tooling match?
- Are fabricators/installers experienced?

Fiber Reinforced Polymers (FRP, Fiberglass)

Material: Fiberglass is the most well known of the FRP products generally produced as a thin rigid laminate shell formed by pouring a polyester or epoxy resin gelcoat into a mold. When tack-free, layers of chopped glass or glass fabric are added along with additional resins. Reinforcing rods and struts can be added if necessary; the gel coat can be pigmented or painted.

Application: Fiberglass, a non load-bearing material attached to a separate structural frame, is frequently used as a replacement where a lightweight element is needed or an inaccessible location makes frequent maintenance of historic materials difficult. Its good molding ability and versatility to represent stone, wood, metal and terra cotta make it an alternative to ornate or carved building elements such as column capitals, bases, spandrel panels, beltcourses, balustrades, window hoods or parapets. Its ability to

reproduce bright colors is a great advantage.

Advantages:

- lightweight, long spans available with a separate structural frame
- high ratio of strength to weight
- good molding ability
- integral color with exposed high quality pigmented gel-coat or takes paint well
- easily installed, can be cut, patched, sanded
- non-corrosive, rot-resistant

Disadvantages:

- requires separate anchorage system
- combustible (fire retardants can be added); fragile to impact.
- high coefficient of expansion and contraction requires frequently placed expansion joints
- ultraviolet sensitive unless surface is coated or pigments are in gelcoat
- vapor impermeability may require ventilation detail

Checklist:

- Can original materials be saved/used?
- Have expansion joints been designed to avoid unsightly appearance?
- Are there standards for color stability/durability?
- Have shop drawings been made for each piece?
- Have samples been matched for color and texture?
- Are fabricators/installers experienced?
- Do codes restrict use of FRP?

Epoxies (Epoxy Concretes, Polymer Concretes)

Material: Epoxy is a resinous two-part thermosetting material used as a consolidant, an adhesive, a patching compound, and as a molding resin. It can repair damaged material or recreate lost features. The resins which are poured into molds are usually mixed with fillers such as sand, or glass spheres, to lighten the mix and modify their expansion/contraction properties. When mixed with aggregates, such as sand or stone chips, they are often called epoxy concrete or polymer concrete, which is a misnomer as there are no cementitious materials contained within the mix. Epoxies are vapor impermeable, which makes detailing of the new elements extremely important so as to avoid trapping moisture behind the replacement material. It can be used with wood, stone, terra cotta, and various metals.

Application: Epoxy is one of the most versatile of the new materials. It can be used to bind together broken fragments of terra cotta; to build up or infill missing sections of ornamental metal; or to cast missing elements of wooden ornaments. Small cast elements can be attached to existing materials or entire new features can be cast. The resins are poured into molds and due to the rapid setting of the material and the need to avoid cracking, the molded units are generally small or hollow inside. Multiple molds can be combined for larger elements. With special rods, the epoxies can be structurally reinforced. Examples of epoxy replacement pieces include: finials, sculptural details, small column capitals, and medallions.

Advantages:

- can be used for repair/replacement
- lightweight, easily installed

- good casting ability; molds can be taken from building material can be sanded and carved.
- color and ultraviolet screening can be added; takes paint well
- durable, rot and fungus resistant

Disadvantages:

- materials are flammable and generate heat as they cure and may be toxic when burned
- toxic materials require special protection for operator and adequate ventilation while curing
- material may be subject to ultraviolet deterioration unless coated or filters added
- rigidity of material
- often must be modified with fillers to match expansion coefficients
- vapor impermeable

Checklist:

- Are historic materials available for molds, or for splicing-in as a repair option?
- Has the epoxy resin been formulated within the expansion/contraction coefficients of adjacent materials?
- Have samples been matched for color/finish?
- Are fabricators/installers experienced?
- Is there a sound substrate of material to avoid deterioration behind new material?
- Are there performance standards?

Summary

Substitute materials--those products used to imitate historic materials--should be used only after all other options for repair and replacement in kind have been ruled out. Because there are so many unknowns regarding the longterm performance of substitute materials, their use should not be considered without a thorough investigation into the proposed materials, the fabricator, the installer, the availability of specifications, and the use of that material in a similar situation in a similar environment.

Substitute materials are normally used when the historic materials or craftsmanship are no longer available, if the original materials are of a poor quality or are causing damage to adjacent materials, or if there are specific code requirements that preclude the use of historic materials. Use of these materials should be limited, since replacement of historic materials on a large scale may jeopardize the integrity of a historic resource. Every means of repairing deteriorating historic materials or replacing them with identical materials should be examined before turning to substitute materials.

The importance of matching the appearance and physical properties of historic materials and, thus, of finding a successful longterm solution cannot be overstated. The successful solutions illustrated in this Brief were from historic preservation projects involving professional teams of architects, engineers, fabricators, and other specialists. Cost was not necessarily a factor, and all agreed that whenever possible, the historic materials should be used. When substitute materials were selected, the solutions were often expensive and were reached only after careful consideration of all options, and with the assistance of expert professionals.

Further Reading

Berryman, Nancy D.; Susan M. Tindal, Terra-Cotta; Preservation of an Historic Material. Chicago: Landmarks Preservation Council of Illinois, 1984.

Brookes, A.J., Cladding of Buildings. New York: Longman Inc., 1983.

Fisher, Thomas, "The Sincerest Form of Flattery," Progressive Architecture (Nov. 1985).

Gayle Margot; David W. Look, AIA; John G. Waite, *Metals in America's Historic Buildings: Uses and Preservation Treatments*. Washington, D.C.: Preservation Assistance Division, National Park Service, U.S. Department of the Interior, 1980.

Historic Building Facades. New York: New York Landmarks Conservancy, 1986.

Hornbostel, Caleb, *Construction Materials: Types, Uses and Applications*, New York: John Wiley and Sons, Inc., 1978.

Lynch, Michael F; William J. Higgins, *The Maintenance and Repair of Architectural Sandstone*, New York Landmarks Conservancy, 1982.

National Park Service, Rocky Mountain Regional Office, *Preservation Briefs 12: The Preservation of Historic Pigmented Structural Glass*. Washington, D.C.: Preservation Assistance Division, National Park Service, U.S. Department of the Interior, 1984.

Phillips, Morgan and Judith Selwyn, *Epoxies for Wood Repairs in Historic Buildings*. Washington, D.C.: Preservation Assistance Division, National Park Service, U.S. Department of the Interior, 1978.

Phillips, Morgan W., *The Morse-Libby Mansion: A Report on Restoration Work*. Washington, D.C.: Preservation Assistance Division, National Park Service, U.S. Department of the Interior, 1977.

Tiller, deTeel Patterson, *Preservation Briefs 7: The Preservation of Historic Glazed Architectural Terra-Cotta*. Washington, D.C.: Preservation Assistance Division, National Park Service, U.S. Department of the Interior, 1979.

Acknowledgements

The author gratefully acknowledges the invaluable assistance of coworker Michael Auer in editing this manuscript. The following individuals are to be thanked for their technical assistance: Mary Oehrlein A.I.A., Washington, D.C.; John G. Waite, Albany, NY; Hyman Myers, R.A., Philadelphia, PA, Thomas Fisher, Stamford, CT; Harrison Goodall, Kinnelon, NJ. In addition, the staff of Preservation Assistance Division, the cultural resources staff of the National Park Service Regional Offices, and Stan Graves, on behalf of the National Conference of State Historic Preservation Officers, provided useful comments that were incorporated into the manuscript.

Washington, D.C. September, 1988.

Home page logo: Cast aluminum used as a replacement for cast iron. Photo: NPS files.

This publication has been prepared pursuant to the National Historic Preservation Act of 1966, as amended, which directs the Secretary of the Interior to develop and make available information concerning historic properties. Technical Preservation Services (TPS), Heritage Preservation Services Division, National Park Service prepares standards, guidelines, and other educational materials on responsible historic preservation treatments for a broad public.

7 Preservation Briefs

Technical Preservation Services

National Park Service
U.S. Department of the Interior

The Preservation of Historic Glazed Architectural Terra-Cotta

de Teel Patterson Tiller

» [What is Terra-Cotta](#)

» [Types of Terra-Cotta](#)

» [Characteristics of Glazed Architectural Terra-Cotta](#)

» [Common Deterioration Problems](#)

» [Deterioration Inspection and Analysis](#)

» [Maintenance, Repair and Replacement](#)

» [Summary](#)

» [Further Reading](#)



A NOTE TO OUR USERS: The web versions of the **Preservation Briefs** differ somewhat from the printed versions. Many illustrations are new, captions are simplified, illustrations are typically in color rather than black and white, and some complex charts have been omitted.

Glazed architectural terra-cotta was significant in the development of important architectural idioms in this country--specifically, the "Chicago School," the High Rise and the Historic or Beaux Arts styles. In fact, glazed architectural terra-cotta is one of the most prevalent masonry building materials found in the urban environment today. Popular between the late 19th century and the 1930s, glazed architectural terra-cotta offered a modular, varied and relatively inexpensive approach to wall and floor construction. It was particularly adaptable to vigorous and rich ornamental detailing. However, with changing vogues in materials and architectural styles and rising production costs, glazed architectural terra-cotta fell into disfavor and disuse by the mid 20th century.

Today, information on the maintenance, rehabilitation and replacement of glazed architectural terra-cotta is limited, as are sources of new glazed architectural terra-cotta. This report, then, will discuss some of the major deterioration problems that commonly occur in historic glazed architectural terra-cotta, methods of determining the extent of that deterioration and recommendations for the maintenance, repair and replacement of the deteriorated historic material.

What is Terra-Cotta?

Generically, the broadest definition of terra-cotta refers to a high grade of weathered or aged clay which, when mixed with sand or with pulverized fired clay, can be molded and fired at high temperatures to a hardness and compactness not obtainable with brick. Simply put, terra-cotta is an enriched molded clay brick or block. The word terra-cotta is derived from the Latin word terra-cotta--literally, "cooked earth." terra-cotta clays vary widely in color according to geography and types, ranging from red and brown to white.

Terra-cotta was usually hollow cast in blocks which were open to the back, like boxes,

with internal compartment-like stiffeners called webbing. Webbing substantially strengthened the load-bearing capacity of the hollow terra-cotta block without greatly increasing its weight.

Terra-cotta blocks were often finished with a glaze; that is, a slip glaze (clay wash) or an aqueous solution of metal salts was brushed or sprayed on the air-dried block before firing. Glazing changed the color, imitated different finishes, and produced a relatively impervious surface on the weather face of the final product. The glaze on the terra-cotta unit possessed excellent weathering properties when properly maintained. It had rich color and provided a hard surface that was not easily chipped off. Glazing offered unlimited and fade-resistant colors to the designer. Even today, few building materials can match the glazes on terra-cotta for the range and, most importantly, the durability of colors.

Types of Terra-cotta

Historically there are four types or categories of terra-cotta which have enjoyed wide use in the history of the American building arts: 1) brownstone, 2) fireproof construction, 3) ceramic veneer, and 4) glazed architectural.

Brownstone terra-cotta is the variety of this masonry material used earliest in American buildings (mid to late 19th century). The brownstone type is a dark red or brown block either glazed (usually a slip glaze) or unglazed. It was hollow cast and was generally used in conjunction with other masonry in imitation of sandstone, brick or real brownstone. It is often found in the architecture of Richard Upjohn, James Renwick, H. H. Richardson and is associated with the Gothic and Romanesque Revival movements through such ornamental detailing as moldings, finials and capitals.

Fireproof construction terra-cotta was extensively developed as a direct result of the growth of the High Rise building in America. Inexpensive, lightweight and fireproof, these rough-finished hollow building blocks were ideally suited to span the I-beam members in floor, wall and ceiling construction. Certain varieties are still in production today, although fireproof construction terra-cotta is no longer widely employed in the building industry.

Ceramic veneer was developed during the 1930s and is still used extensively in building construction today. Unlike traditional architectural terra-cotta, ceramic veneer is not hollow cast, but is as its name implies: a veneer of glazed ceramic tile which is ribbed on the back in much the same fashion as bathroom tile. Ceramic veneer is frequently attached to a grid of metal ties which has been anchored to the building.



Glazed architectural terra-cotta was a practical and highly decorative building material. Photo: NPS files.

Glazed architectural terra-cotta was the most complex development of terra-cotta as a masonry building material in this country. The hollow units were hand cast in molds or carved in clay and heavily glazed (often in imitation of stone) and fired. Sometimes called "architectural ceramics," glazed architectural terra-cotta was developed and refined throughout the first third of the 20th century and has been closely associated with the architecture of Cass Gilbert, Louis Sullivan, and Daniel H. Burnham, among others. Significant examples in this country include the Woolworth Building (1913) in New York City and the Wrigley Building (1921) in Chicago.

Late 19th and early 20th century advertising promoted the durable, impervious and adaptable nature of glazed architectural terra-cotta. It provided for crisp, vigorous modeling of architectural details as the molds were cast directly from clay prototypes without loss of refinement. Glazed architectural terra-cotta could accommodate subtle nuances of modeling, texture and color. Compared to stone, it was easier to handle, quickly set and more affordable to use. Thought to be fireproof and waterproof, it was readily adaptable to structures of almost any height. The cost of molding the clay, glazing and firing the blocks, when compared to carving stone, represented a considerable savings, especially when casts were used in a modular fashion--that is, repeated over and over again. Maintenance of the fired and glazed surface was easy; it never needed paint and periodic washings restored its original appearance.

With the passage of time, many of the phenomenal claims of the early proponents of glazed architectural terra-cotta have proven true. There are many examples throughout this country that attest to the durability and permanence of this material. Yet present-day deterioration of other significant glazed architectural terra-cotta resources ultimately belie those claims. Why? Historically, the lack of foresight or understanding about the nature and limitations of the material has, in many instances, allowed serious deterioration problems to occur that are only now becoming apparent.

Characteristics of Glazed Architectural Terra-cotta as a Building Material

Glazed architectural terra-cotta has many material properties similar to brick or stone. It also has many material properties radically different from those traditional masonry materials. It is those differences which must be considered for a better understanding of some of the material characteristics of glazed architectural terra-cotta when it is used as a building material.

Difficult to identify: Glazed architectural terra-cotta probably comprises one of the largest if not the largest constituent material in some of our urban environments today. However, the infinite varieties of glazing have hidden this fact from the casual observer. One of the attractive features of glazed architectural terra-cotta in its time was that it could be finished (glazed) in exact imitation of stone. In fact, many building owners and architects alike are often surprised to discover that what they presumed to be a granite or limestone building is glazed architectural terra-cotta instead.

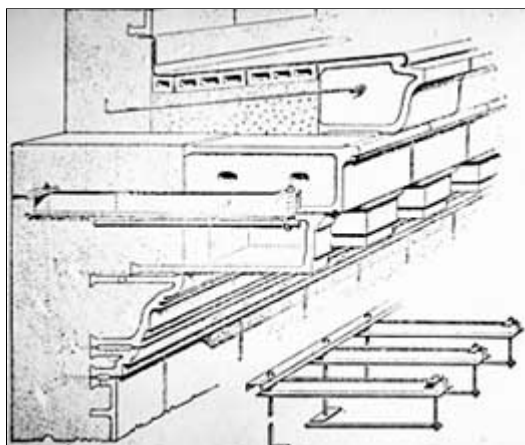

Typical construction detail of glazed architectural terra-cotta ornament. Drawing: Detail, Architectural Terra Cotta, Charles E. White, Jr., 1920.

Two separate systems: Historically, glazed architectural terra-cotta has been used in association with two specific and very different types of building systems: as part of a traditional load-bearing masonry wall in buildings of modest height, and as a cladding material in High Rise construction. As cladding, glazed architectural terra-cotta often utilized an extensive metal anchoring system to attach it or to "hang it" onto a wall framing system or superstructure. In the first instance the anchoring was limited; in the second, the anchoring was often extensive and complex. Likewise, in the first instance, deterioration has generally been limited. However, where glazed architectural terra-cotta was used as cladding, particularly in high rise construction, present-day deterioration and failure are often

severe.

Complexity of deterioration: Deterioration is, by nature of the design, infinitely complex--particularly when glazed architectural terra-cotta has been used as a cladding material.

Deterioration creates a "domino"-like breakdown of the whole system: glazed units, mortar, metal anchors, and masonry backfill. In no other masonry system is material failure potentially so complicated.

Poor original design: The root of deterioration in glazed architectural terra-cotta systems often lies in a misapplication of the material. Historically, glazed architectural terra-cotta was viewed as a highly waterproof system needing neither flashing, weep holes nor drips. This supposition, however, has proved to be untrue, as serious water-related failure was evident early in the life of many glazed architectural terra-cotta clad or detailed buildings.

Common Deterioration Problems

No one case of deterioration in glazed architectural terra-cotta is ever identical to another owing to the infinite number of variations with the material: original manufacture, original installation inconsistencies, number of component parts, ongoing repairs or the various types and sources of deterioration. However, certain general statements may be made on the nature of glazed architectural terra-cotta deterioration.

Material failure can most commonly be attributed to water-related problems. However, less frequent though no less severe causes may include: faulty original craftsmanship, which is often cited but hard to determine; stress-related deterioration; damage caused by later alterations and additions; or inappropriate repairs.

Water-related deterioration: As with most building conservation and rehabilitation problems, water is a principal source of deterioration in glazed architectural terra-cotta. Terra-cotta systems are highly susceptible to such complex water-related deterioration problems as glaze crazing, glaze spalling and material loss, missing masonry units and deteriorated metal anchoring, among others.

Crazing, or the formation of small random cracks in the glaze, is a common form of water-related deterioration in glazed architectural terra-cotta. When the new terra-cotta unit first comes from the kiln after firing, it has shrunk (dried) to its smallest possible size. With the passage of time, however, it expands as it absorbs moisture from the air, a process which may continue for many years. The glaze then goes into tension because it has a lesser capacity for expansion than the porous tile body; it no longer "fits" the expanding unit onto which it was originally fired. If the strength of the glaze is exceeded, it will crack (craze). Crazing is a process not unlike the random hairline cracking on the surface of an old oil painting. Both may occur as a normal process in the aging of the material. Unless the cracks visibly extend into the porous tile body beneath the glaze, crazing should not be regarded as highly serious material failure. It does, however, tend to increase the water absorption capability of the glazed architectural terra-cotta unit.

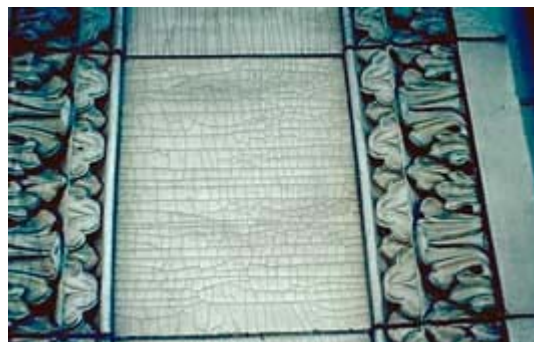

Water and air-borne moisture entering the glazed architectural terra-cotta causes expansion of the porous clay body, increasing its volume. This upsets the "fit" of the glaze and makes its surface shatter, which is commonly called "crazing." Photo: NPS files.

Spalling, the partial loss of the masonry material itself, is, like crazing, caused by water and is usually a result not only of airborne water but more commonly of water trapped

within the masonry system itself. Trapped water is often caused by poor water detailing in the original design, insufficient maintenance, rising damp or a leaking roof. In most cases, trapped water tends to migrate outward through masonry walls where it eventually evaporates. In glazed architectural terra-cotta, the water is impeded in its journey by the relatively impervious glaze on the surface of the unit which acts as a water barrier. The water is stopped at the glaze until it builds up sufficient pressure (particularly in the presence of widely fluctuating temperatures) to pop off sections of the glaze (glaze spalling) or to cause the wholesale destruction of portions of the glazed architectural terra-cotta unit itself (material spalling).



Blistering of the glaze, like crazing, is the result of the increase in water in the porous clay body and the subsequent destruction of the glaze as a result of water migration and pressure. Glaze spalling may also be caused by deterioration of metal anchors behind the terra-cotta unit. Photo: NPS files.

Glaze spalling (left) may appear as small coin-size blisters where the glaze has ruptured and exposed the porous tile body beneath. This may occur as several spots on the surface or, in more advanced cases of deterioration, it may result in the wholesale disappearance of the glaze. Spalling of the glaze may also be symptomatic of deterioration (rusting) of the internal metal anchoring system which holds the terra-cotta units together and to the larger building structure. The increase in volume of the metal created by rusting creates increased internal pressures in the terra-cotta unit which, in turn, may spall the glaze, or in more extreme cases, cause material spalling.

Material spalling is a particularly severe situation. Not only is the visual integrity of the detailing impaired, but a large area of the porous underbody, webbing and metal anchoring is exposed to the destructive effects of further water entry and deterioration. Both glaze and material spalling must be dealt with as soon as possible.

Missing units is a serious situation which particularly plagues architectural terra-cotta systems. Unlike brick or stone, damaged glazed architectural terra-cotta is exceedingly difficult to replace. New production is extremely limited. Missing units create gaps which increase the structural load on the remaining pieces and also permit water to enter the system. Exposed or freestanding glazed architectural terra-cotta detailing (balusters, urns, parapet walls, etc.) are particularly susceptible to extensive loss of material.

These elements face the most severe vicissitudes of water and temperature-related deterioration in direct proportion to the extent of their exposure. The replacement of missing units should be a high priority work item in the rehabilitation of glazed architectural terra-cotta.

Deterioration of metal anchoring: Deteriorated anchoring systems are perhaps the most difficult form of glazed architectural terra-cotta deterioration to locate or diagnose. Often, the damage must be severe and irreparable before it is noticed on even the most intense "prima facie" examination. Water which enters the glazed architectural terra-cotta system can rust the anchoring system and substantially weaken or completely disintegrate those elements. Where water has been permitted to enter the system, some deterioration has more than likely taken place. Partial deterioration results in staining and material spalling. Total deterioration and the lack of any anchoring system may result in the loosening of the units themselves, threatening the architectural or structural integrity of the building. Recently, falling glazed architectural terra-cotta units have become a serious safety concern to many building owners and municipal governments. Early detection of failing anchoring systems is exceedingly difficult.

Deterioration of mortar and other adjacent materials: Deteriorated mortar has always been a key to the survival or failure of any masonry system. This is particularly true with glazed architectural terra-cotta. In recognition of the fragile nature of the system, the need for insuring a relatively dry internal system is important. Sound mortar is the "first line" of defense in terra-cotta systems. It is a maintenance "must." Deteriorated mortar joints are a singularly culpable source of water and, therefore, of deterioration. Mortar deterioration may result from improper original craftsmanship or air--and waterborne--pollution. More often, however, lack of ongoing maintenance is mainly responsible. Deteriorated mortar should not be overlooked as a major source of glazed architectural terra-cotta failure.

The deterioration of materials adjoining the glazed architectural terra-cotta (flashing, capping, roofing, caulking around windows and doors) bears significant responsibility in its deterioration. When these adjoining materials fail, largely as a result of lack of maintenance, water-related deterioration results. For instance, it is not uncommon to find wholesale terra-cotta spalling in close proximity to a window or doorway where the caulking has deteriorated.



The damage shown here is the result of direct live load on a mid-rise building. The steel frame has settled and shifted the weight onto the exterior terra-cotta cladding, resulting in rupturing of the material. Photo: NPS files.

Stress-related deterioration: Stress-related deterioration of glazed architectural terra-cotta frequently occurs in high rise buildings. The evolution of stress relieving details (flexible joints, shelf angles, etc.) occurred late in the development of American building construction. Consequently, most early continuously clad High Rise buildings (c.1900-1920s) had little or no provisions for normal material and building movement in their original design.

The development of large stress-related cracks or wholesale material deterioration is often caused by unaccommodated building-frame shortening under load, thermal expansion and contraction of the facade and moisture expansion of the glazed architectural terra-cotta units themselves. Cracks running through many units or stories or large areas of material deterioration often indicate stress-related problems. This sort of deterioration, in turn, permits significant water entry into the terra-cotta system.

Inappropriate repairs: Inappropriate repairs result because using new terra-cotta for replacement of deteriorated or missing glazed architectural terra-cotta has generally been impractical. Repairs, therefore, have traditionally been made in brick or cementitious build ups of numerous materials such as stucco or fiberglass. Some materials are appropriate temporary or permanent replacements, while others are not. (These issues are discussed at a later point in this report.) However, improper anchoring or bonding of the repair work or visual incompatibility of repairs have themselves, with the passage of time, become rehabilitation problems: replacement brick that is pulling free, cement stucco that is cracking and spalling, or a cement or bituminous repairs that are not visually compatible with the original material.

Alteration damage: Alteration damage has occurred as a result of the installation of such building additions as signs, screens, marquees or bird proofing. These installations often necessitated the boring of holes or cutting of the glazed architectural terra-cotta to anchor these additions to the building frame beneath. As the anchoring or caulking deteriorated, or as these elements were removed in subsequent renovation work, these holes have become significant sources of water-related damage to the glazed architectural terra-cotta system.

Deterioration Inspection and Analysis

Certain deterioration in glazed architectural terra-cotta may be on the building surface and patently obvious to the casual observer--crazing, spalling, deterioration of mortar joints. Other deterioration may be internal or within the masonry system and hard to determine--deterioration of anchoring, deterioration behind the glaze, crumbling of internal webbing. *Prima facie*, "first inspection," examination may indicate surface deterioration problems while not revealing others. This demonstrates one of the most frustrating aspects of dealing with deteriorated glazed architectural terra-cotta: that there are two systems or levels of deterioration, one which is visible and the other which is not.

Material failure in glazed architectural terra-cotta is necessarily complex. For this reason, it is generally advised that the examination and repair of this material should be the responsibility of an experienced professional. Few restorationists have experience in the inspection, repair and replacement of glazed architectural terra-cotta. This is certainly never the province of the amateur or the most well-intentioned but inexperienced architect or engineer.

There are some methods of internal and external inspection and analysis which are relatively simple to the trained professional. Other methods, however, are expensive, time consuming, and only in the experimental stage at this writing. These all generally preclude the use of anyone but an experienced professional.



Material spalling is the result of excessive expansion of the porous tile body caused by water and freezing temperatures. This is a serious condition, often difficult to repair. Photo: NPS files.

Preliminary cleaning: Before a terra-cotta building is analyzed for deterioration, it is often advisable, but not always necessary, to clean the surface of the material. This is particularly true when the material has been exposed to the vicissitudes of heavy urban pollution. While most building materials are cleaned for "cosmetic" purposes, the cleaning of glazed architectural terra-cotta for the purpose of inspection and analysis may be advised. Dirt on glazed architectural terra-cotta often hides a multitude of problems. It is only with cleaning that these problems become obvious. Recommended cleaning procedures are covered later in the report.

Methods of inspection: *Prima facie analysis* is the unit by unit, firsthand, external inspection of the glazed architectural terra-cotta building surface. Special note of all visible surface deterioration (staining, crazing, spalling, cracking, etc.) should be made on elevation drawings. Binoculars are often used where cost, height, or inaccessibility prevent easy inspection. However, much deterioration may go unnoticed unless scaffolding or window-washing apparatus is used in a true "hands on" inspection of each unit of the facade.

Tapping, a somewhat inexact method of detection of internal deterioration is, nevertheless, the most reliable inspection procedure presently available. Quite simply, tapping is the striking of each unit with a wooden mallet. When struck, an undamaged glazed architectural terra-cotta unit gives a pronounced ring, indicating its sound internal condition. Conversely, deteriorated units (i.e., units which are failing internally) produce a flat, hollow sound. Metal hammers are never to be used, as they may damage the glazed surface of the unit. Extensive experience is the best teacher with this inspection method.

Infrared scanning is only in the experimental stage at this time, but its use seems to hold great promise in locating deteriorated internal material in terra-cotta. All materials emit heat--heat which can be measured in terms of infrared light. While infrared light cannot be seen by the human eye, it can be measured by infrared scanning. Infrared photography, a kind of infrared scanning, has been of particular use in detecting sources of heat loss in buildings in recent years. Broken or loose internal terra-cotta pieces have a less firm attachment to the surrounding firm or attached pieces and, therefore, have different thermal properties, i.e., temperatures. These temperature differences become evident on the infrared scan and may serve as a fair indication of internal material deterioration in terra-cotta.

Sonic testing has been successfully used for some time to detect internal cracking of concrete members. In the hands of an experienced operator, there are conditions where it can detect internal failure in glazed architectural terra-cotta. Sonic testing registers the internal configuration of materials by penetrating the material with sound waves and reading the patterns that "bounce back" from the originating source of the sound. Readings at variance with those from undeteriorated material might indicate collapsed webbing or pools of water in the interior of the terra-cotta unit.

Metal detection is a non-destructive and generally useful way of locating the position of internal metal anchoring. Metal detectors indicate the presence of metals by electromagnetic impulses. These impulses are transmitted onto an oscilloscope where they may be seen or they are converted to sound patterns which may be heard by the operator. Original drawings are eminently useful in predicting where internal metal anchoring should be. Metal detectors can confirm that indeed they are still there. Without original drawings, the contractor or architect can still locate the metal anchoring, however. No reading where an anchor would be expected could indicate a missing anchor or one that has seriously deteriorated. The information produced by metal detection is, at best, only rough. However, it is the most viable way of locating the internal metal anchoring without physically removing, thus irreparably damaging, the glazed architectural terra-cotta units themselves.

Laboratory analysis may be carried out on samples of removed original material to find glaze absorption, permeability or glaze adhesion, or to evaluate material for porosity. These tests are useful in determining the present material characteristics of the historic glazed architectural terra-cotta and how they may be expected to perform in the future.

Maintenance, Repair and Replacement

Deterioration in glazed architectural terra-cotta is, by definition, insidious in that the outward signs of decay do not always indicate the more serious problems within. It is, therefore, of paramount importance that the repair and replacement of deteriorated glazed architectural terra-cotta not be undertaken unless the causes of that deterioration have been determined and repaired. As mentioned before, one of the primary agents of deterioration in glazed architectural terra-cotta is water. Therefore, water-related damage can be repaired only when the sources of that water have been eliminated. Repointing, caulking and replacement of missing masonry pieces are also of primary concern. Where detailing to conduct water in the original design has been insufficient, the installation of new flashing or weep holes might be considered.



Exposed or freestanding terra-cotta detailing (parapets, urns, balusters, etc.) have traditionally been subjected to the most severe vicissitudes of deterioration as a result of freezing temperatures and water. Photo: NPS files.

Where stress-related or structural problems have caused the deterioration of glazed architectural terra-cotta, the services of a structural engineer should be sought to mitigate these problems. This may include the installation of relieving joints, shelf angles or flexible joints. In any case, stress-related and structural deterioration, like water-related deterioration, must be stopped before effective consolidation or replacement efforts may begin.

Cleaning: The successful cleaning of glazed architectural terra-cotta removes excessive soil from the glazed surface without damaging the masonry unit itself. Of the many cleaning materials available, the most widely recommended are water, detergent, and a natural or nylon bristle brush. More stubborn pollution or fire-related dirt or bird droppings can be cleaned with steam or weak solutions of muriatic or oxalic acid.

A note of caution: Any acids, when used in strong enough solutions, may themselves deteriorate mortar and "liberate" salts within the masonry system, producing a situation called efflorescence.

Commercial cleaning solutions may be appropriate but probably are not necessary when water and detergent will suffice. There are, however, certain cleaning techniques for glazed terra-cotta which are definitely not recommended and which would damage the surface of the material. These include: all abrasive cleaning measures (especially sandblasting), the use of strong acids, (particularly fluoride-based acids), high-pressure water cleaning and the use of metal bristle brushes. All of these techniques will irreparably harm the glaze in one fashion or another and subsequently expose the porous tile body to the damaging effects of water.

It is important to remember that glazed architectural terra-cotta was designed to be cleaned cheaply and easily. This, in fact, was one of its major assets and was much advertised in the selling of the material early in this century.

Waterproofing: The covering of crazed glazing with waterproof coatings is the subject of an ongoing controversy today. The question involves whether or not the micro-cracks conduct substantial amounts of water into the porous tile body. Tests indicate that the glaze on new unexposed terra-cotta is itself not completely waterproof. Some testing also indicates that most crazing on historic glazed terra-cotta does not substantially increase the flow of moisture into the porous tile body when compared to new material. Excessive and serious crazing is, however, an exception and the coating of those areas on a limited scale may be wholly appropriate.

In an effort to stem water-related deterioration, architects and building owners often erroneously attribute water-related damage to glaze crazing when the source of the deterioration is, in fact, elsewhere: deteriorated caulking, flashing, etc. The waterproof coating of glazed architectural terra-cotta walls may cause problems on its own. Outward migration of water vapor normally occurs through the mortar joints in these systems. The inadvertent sealing of these joints in the wholesale coating of the wall may exacerbate an already serious situation. Spalling of the glaze, mortar, or porous body will, more than likely, result.



A worker cleans out mortar joints in preparation for repointing the architectural terra-cotta. Photo: NPS files.

Repointing: Repointing of mortar which is severely deteriorated or improperly or infrequently maintained is one of the most useful preservation activities that can be performed on historic glazed architectural terra-cotta buildings. Ongoing and cyclical repointing guarantees the long life of this material. Repointing should always be carried out with a mortar which has a compressive strength (measured in p.s.i.) *lower* than the adjacent masonry unit. Hard (Portland cement) or coarsely screened mortars may cause point loading and/or prevent the outward migration of the water through the mortar joints, both of which ultimately damage the terra-cotta unit. Repointing with waterproof caulking compounds or similar waterproof materials should never be undertaken because, like waterproof coatings, they impede the normal outward migration of moisture through the masonry joints. Moisture then may build sufficient pressure behind the waterproof caulk and the glaze on the terra-cotta to cause damage to the unit itself.

Repair of glaze spalling: Glaze spalling is also a highly culpable source of water-related deterioration in glazed architectural terra-cotta. It is important to coat or seal these blistered areas and to prevent further entry of water into the system by this route. All loose or friable material should be removed. This may be done easily by hand; chisels or similar small tools are most effective. The exposed material is then painted over. At this time, no permanently effective reglazing materials are available. However, there are several acrylic-based proprietary products and masonry paints which can be used effectively to protect these exposed areas, thus preventing the entry of water. These materials are effective for 5 to 7 years and can be reapplied. They also can be tinted to approximate closely the original glaze color.

Repair of minor material spalling: Minor material spalling, where visual or cosmetic considerations are negligible, should be treated in a manner similar to glaze spalling damage. That is, areas where small portions of the body and glaze have spalled and which are far removed from close scrutiny (i.e., detailing on entablatures, upper story windows, etc.) are best remedied by painting with a masonry paint or an acrylic-based proprietary product. Units on which material spalling is easily observed (on the street level, door surrounds, etc.), and on which visual integrity is a consideration, may be better replaced. Patching is not appropriate. Stucco-like or cementitious buildups are difficult to form satisfactorily, safely and compatibly *in situ* to replace missing pieces of glazed architectural terra-cotta. Cementitious repairs never satisfactorily bond to the original material. The differential expansion coefficients of the two materials (the repair and the original) preclude a safe, effective and long-term attachment.

Repair of major spalling: Glazed architectural terra-cotta units, which have spalled severely thereby losing much of their material and structural integrity in the wall, should be replaced. Partial in situ repair will not be long lasting and may, in fact, cause complicated restoration problems at a later date. Appropriate methods of replacement are discussed at a later point in this report.

Temporary stabilization: Stabilization measures are necessary when deterioration is so severe as to create a situation where pieces of glazed architectural terra-cotta may fall from the building. This is a particular concern with greatly exposed detailing: cornices, balconies, balustrades, urns, columns, buttresses, etc. Restoration work on these pieces is expensive and often must be carried on over a period of time. Unstable terra-cotta pieces are often removed or destroyed in lieu of such measures. This is particularly true in areas of heavy traffic-related vibrations or in earthquake zones. There are, however, less severe measures which may be employed on a temporary basis. Substantial success has been achieved in securing unstable glazed architectural

terra-cotta pieces with metal strapping and nylon net. While these measures should not be seen as permanent preservation solutions, they do offer temporary alternatives to the wanton destruction of significant glazed architectural terra-cotta detailing in the name of public safety and local code compliance.

Repair of addition and structural

damage: Holes, sign anchors, slots for channel steel, or structural cracking in the surface of glazed architectural terra-cotta cladding should be permanently sealed with a material that will expand with the normal dynamics of the surrounding material, yet effectively keep water out of the system. Any one of a number of commercially available waterproof caulking compounds would be appropriate for this work. Holes and static (non-moving) cracks may be caulked with butyl sealants or acrylic latex caulks. For dynamic (moving or active) cracks, the polysulfide caulks are most often used, although others may be safely employed. It is, however, important to remember that these waterproof caulking compounds are not viable repointing materials and should not be used as such.



This crack is being measured. Structural cracking, whether static (nonmoving) or dynamic (moving) should be caulked to prevent water entry into the glazed architectural terra-cotta system. Photo: NPS files.

Temporary replacement: Temporary replacement measures should be implemented when missing units are scheduled to be replaced but work cannot be undertaken immediately. Lengthy delivery time, prorating of work or seasonal considerations may postpone replacement work. Severe deterioration should at least be ameliorated until work can begin. Temporary repointing, removal and saving of undamaged units to be reset later, or the temporary installation of brick infill to retard further deterioration might be considered.

Removing earlier repairs: Removing earlier repairs may be necessary when the work has either deteriorated or has become visually incompatible. Cementitious stucco, caulking with black bituminous compounds or brick repair work may become structurally or visually unstable or incompatible and should be removed and properly rehabilitated.

Replacement of glazed architectural terra-cotta: Replacement of severely spalled, damaged, or missing glazed architectural terra-cotta elements is always difficult. Certainly, in-kind replacement is advisable, but it has a number of drawbacks. Stone, fiberglass, and precast concrete are also viable choices, but like in-kind replacement, also have their inherent problems.

Several notes on replacement: When replacing glazed architectural terra-cotta, all of the original deteriorated material should be completely removed. Half bricks or similar cosmetic replacement techniques are not advised.

-- When possible and where applicable, replacement units should be anchored in a manner similar to the original. Both structural and visual compatibility are major considerations when choosing replacement materials.

-- Removing and re-anchoring damaged glazed architectural terra-cotta is an extremely difficult if not impossible task. The complexity of the interlocking system of masonry units, backfill, and metal anchoring system precludes the removal of the glazed architectural terra-cotta unit without destroying it.

-- Re-anchoring deteriorated units is likewise impossible. Therefore, if the terra-cotta in

question is loose, severely deteriorated, or its structural integrity in serious question, it is best removed and replaced.

In-kind replacement is possible today, but only on a limited basis. Most new glazed architectural terra-cotta is machine made, not hand made as the original. Thus, the porous tile body of the new material tends to be more uniform but less dense and often not as durable. The glaze on the new glazed architectural terra-cotta tends to be thinner than that on the older material and subsequently more brittle. Machine processing has also produced a glaze that is uniform in color as opposed to historic glazes which were slightly mottled and, therefore, richer. Visual compatibility is an important consideration when replacing in-kind.

Only a fairly limited inventory of in-kind pieces is presently available for replacement such as plain ashlar blocks and the simpler details such as cappings and sills. When deterioration severely damages the more ornate pieces (urns, cartouche work, balusters, etc.) either expensive hand casting or alternative materials must be sought. There is a tendency today to replace damaged ornamental work with simpler, cheaper and more readily available units. This decision cannot, however, be supported, as the removal of this work inevitably diminishes the character and integrity of the building. Another major consideration in choosing in-kind replacement is the question of delivery time, which is often quite lengthy. If new glazed architectural terra-cotta is chosen as a replacement material, the architect or building owner should plan far in advance.

Stone may be a suitable replacement material for damaged glazed architectural terra-cotta. Its durability makes it highly appropriate, although the increase in weight over the original hollow units may be of some concern. The fact that historic glazed architectural terra-cotta was glazed in imitation of stone, however, may make the choice of stone as a replacement material a fortuitous one. Metal anchoring may be accommodated easily in the carving. Cost, however, is the major drawback in stone replacement, particularly where rich detailing must be carved to match the original.

Fiberglass replacement is a viable alternative, particularly when rich and elaborate ornamentation has to be duplicated. Casting from original intact pieces can produce numerous sharp copies of entablatures, moldings, balusters, voussoirs, etc. Anchoring is easily included in casting.

Significant drawbacks in using fiberglass replacement are color compatibility, fire code violations, and poor weathering and aging processes. The appropriate coloring of fiberglass is exceedingly difficult in many instances. Painting is often unsatisfactory, as it discolors at a rate different than that of the historic glazed original. While fiberglass casting is lighter than the original units and, therefore, of great interest in the rehabilitation of buildings in areas of high seismic activity, many fire code requirements cannot be met with the use of this material.

Precast concrete units show great promise in replacing glazed architectural terra-cotta at this writing. Precast concrete units can, like fiberglass, replicate nuances of detail in a modular fashion: they can also be cast hollow, use lightweight aggregate and be made to accommodate metal anchoring when necessary. Concrete can be colored or tinted to match the original material with excellent results. It is cost effective and once production is in process, precast concrete can be produced quickly and easily.

Experience shows that it is advisable to use a clear masonry coating on the weather face of the precast concrete units to guarantee the visual compatibility of the new unit, to prevent moisture absorption, to obtain the proper reflectivity in imitation of the original glaze and to prevent weathering of the unit itself. Precast concrete replacement units are presently enjoying great use in replicating historic glazed architectural terra-cotta and show promise for future rehabilitation programs.

Once the replacement material is selected (new glazed architectural terra-cotta, stone,

precast concrete, or fiberglass), it must be reanchored into the masonry system. Original metal anchoring came in numerous designs, materials and coatings ranging from bituminous-coated iron to bronze. While most of these anchors are no longer available, they may be easily replicated in large quantities either in the original material when appropriate or out of more durable and available metals such as stainless steel.

Since the masonry backfill is already in place in the historic building, the new replacement unit with anchoring may simply be fitted into the existing backfill by boring a hole or slot for anchor and bedding the anchor and the unit itself in mortar. When replacing historic glazed architectural terra-cotta which originally employed metal anchoring, it is important to replace that anchoring when replacing the unit. Serious problems may result if anchoring is omitted in restoration, when it was used originally. It is erroneous to assume that mortar alone will be sufficient to hold these replacement pieces in place.

Summary

Today, many of this country's buildings are constructed of glazed architectural terra-cotta. However, many of these are in a state of serious deterioration and decay. Glazed architectural terra-cotta was, in many ways, the "wonder" material of the American building industry in the late 19th century and during the first decades of the 20th century. New technology and methods of rehabilitation now hold promise for the restoration and rehabilitation of these invaluable and significant resources. Restoration/rehabilitation work on glazed architectural terra-cotta is demanding and will not tolerate halfway measures. Today's preservation work should equal the spirit, attention to detail, pride in workmanship and care which characterized the craftsmanship associated with this widely used, historic masonry material.

Suggested Further Readings

"Recipes for Baked Earth." *Progressive Architecture* (November, 1977).

McIntyre, W.A. *Investigations into the Durability of Architectural Terra Cotta*. Special Report 12. London: Department of Scientific and Industrial Research, Building Research Station, 1929.

Prudon, Theodore H.M. "Architectural Terra-cotta: Analyzing the Deterioration Problems and Restoration Approaches." *Technology and Conservation*, Vol. 3 (Fall, 1978), pp. 30-38.

Prudon, Theodore H.M. *Terra Cotta as a Building Material*. A Bibliography. Ottawa, Ontario: Association for Preservation Technology, 1976.

Acknowledgements

This Preservation Brief was written by de Teel Patterson Tiller, Architectural Historian, Technical Preservation Services Division. Information for this publication was based in part upon interviews and consultation with Theodore H.M. Prudon, The Ehrenkrantz Group, P.C., New York, New York. Additional comments and information were provided by Si A. Bortz, Illinois Institute of Technology Research Institute, Chicago, Illinois, and Jerry G. Stockbridge, Wiss, Janney, Elstner, and Associates, Northbrook, Illinois.

Washington, D.C. June, 1979

Home page logo: Terra-cotta detail on the Adams Hotel, Tulsa, Oklahoma. Photo: NPS files.

This publication has been prepared pursuant to the National Historic Preservation Act of 1966, as amended, which directs the Secretary of the Interior to develop and make



AQUATHANE UA-210

Waterborne Polyurethane Coatings



PHOTO, ABOVE: Dozens of custom Aquathane UA210 NCL colors were used to restore decorative terra cotta elements at this Florida museum.



Specialty Coatings for Special Applications:

- ✓ **ARCHITECTURAL**
- ✓ **ANTI-GRAFFITI**
- ✓ **TERRA COTTA RESTORATION**
- ✓ **INDUSTRIAL**
- ✓ **ANTI-CORROSION**

PHOTO: Three custom colors of Aquathane UA210 E were used on extensive terra cotta glaze repairs at this Historic Register site.

AQUATHANE UA210-Series

DESCRIPTION:

AQUATHANE UA-210 series products are high-performance waterborne polyurethane-based coatings. They are breathing, low in odor, VOC-Compliant and fast drying. The series includes products which cure to tough, flexible films of varying degrees of hardness for different applications.

APPLICATIONS:

AQUATHANE UA-210 applications include:

- ✓ Anti-Graffiti Coatings - Interior and Exterior
- ✓ Terra Cotta and Brick Glaze Replication
- ✓ UV-Stable, Chemical Resistant Seal Coats for Epoxy Flooring
- ✓ Wood, Stone and Concrete Sealers
- ✓ Stain Resistant Wall & Floor Coatings
- ✓ Many Previously Coated Surfaces

COLORS & FINISHES:

AQUATHANE UA210-Series products are available in Clear and 900 standard colors. Custom color matching is also available.

AQUATHANE UA-210 tint bases allow Edison Coatings Dealers to perform immediate in-house tinting.

Gloss, Satin and Flat Finishes are offered.

AQUATHANE UA-210 Products

TYPE H

Severe Service
Type H is a reactive polyurethane emulsion designed for use in the most challenging applications. This self-crosslinking aliphatic urethane resists abrasion and intermittent exposure to water and many chemicals. It is used in interior and exterior concrete floor and deck coating, maintenance coating and many other specialty applications. Clear **Type H** is USDA-accepted for use on incidental food contact surfaces in federally inspected meat and poultry packing plants.

TYPE A/G

Anti-Graffiti
Similar in composition and appearance to **Type H**, the **A/G** formulation incorporates fluoropolymer stain-release agents to facilitate removal of spray paints, inks, crayons, markers and other coatings. **AQUATHANE UA-210 TYPE A/G** does not darken or discolor most surfaces. Low odor application permits easy use and touch-up in interior applications such as school buildings, residential hallways, underground parking structures, elevators and many institutional settings. Product resists hydrocarbon solvents typically incorporated in paints, markers and other coatings, allowing removal by use of similar solvents or proprietary cleaners.

TYPE NCL

Heavy Duty
Closely related in composition to **Type H**, **Type NCL** omits the self-crosslinking feature to produce more flexible films. Long service life and excellent appearance retention make **Type NCL** the preferred grade for wood finishing and other heavy-duty applications.

TYPE E

Architectural/Elastomeric
This highly flexibilized grade is designed for use on a wide variety of substrates. It may be used directly over porous substrates or in conjunction with **Type G Bonding Additive** or **#240 Primer** over glazed brick, terra cotta, polished stone and other substrates. It may be used over **Elastowall 351 and Elasto-Deck 350** breathable coatings, to provide luster and abrasion resistance without compromising crack-bridging performance. It has also been used as a seal coat over thermally sprayed zinc protection systems for steel structures, where the product's excellent resistance to weather and water extend the service life of the protective zinc treatment.

TYPE EE

Elastomeric
This highly elastomeric grade may be used wherever higher elongations and deflection are required. Sports floors, exterior decks and balconies are typical uses.

TYPE F

Floor Sealer
Type F provides a tough, traffic resistant film for sealing and dust-proofing concrete floors and providing resistance to intermittent exposure to a variety of chemicals.



ADDITIVES & PRIMERS

Special additives are available to aid in the achievement of particular objectives.

TYPE G ADDITIVE:

Glass, Ceramic, Non-Porous Surfaces
For applications on glass, glazed masonry, hard stone, smooth/dense concrete and other non-porous substrates, **Type G Additive** is used to chemically bond **AQUATHANE UA-210** coatings to the substrate. The additive reacts with limestone, sandstone, concrete, marble, granite, stucco, iron, aluminum, lime and masonry mortars, resulting in durable adhesion. NOTE: Use of **Type G Additive** is not a replacement for proper cleaning, and surfaces cleaned with acidic cleaners must be neutralized with an alkaline detergent after-wash and thoroughly rinsed with clean water.

TYPE A/G ADDITIVE

Stain Release
This fluoropolymer additive may be added to any grade of **AQUATHANE UA-210** to improve resistance to staining, paints and markers.

#240 PRIMER

Dense Surfaces
This one-component waterborne primer develops high bond strength to a wide variety of surfaces, including glazed brick, terra cotta, hard-finished concrete and polished stone.

AQUAPRIME 211Z

Metal Primer
Corrosion-resistant zinc/acrylic primer for steel, galvanized steel and aluminum.

PROPERTIES	
PROPERTY	DESCRIPTION
Chemical Resistance* (After 7-day air dry)	Resists solvents, paints, markers, fuels, oils & water Toluene, 24 hr. Imm. No Effect Gasoline, 24 hr. Imm. No Effect Sodium Hydroxide, 1N, 1-hour spot test No Effect Methanol, 24 hr. Imm. Softens, Recovers Isopropanol, 24 hr. Imm. Softens, Recovers Water, 90-day immers. Swells, Recovers M. E. K. Rub Resistance 150+ Passed
Corrosion Resistance*, Humidity (100°F, 100% RH, 1000 hrs.)	Rusting (ASTM D-610) No effect Blistering (ASTM D-714) No effect Loss in Gloss No effect
UV Stability, ASTM G53, 6000 hrs.	Stable, dE<5; Premium, UV-Stable aliphatic urethane composition provides long service life for typical architectural and industrial applications
60° Gloss, Gardner	91 (Clear Gloss Formula)
Fast Drying (70°F, 50% RH)	Dry to touch: 30-60 minutes; Through dry: 60-120 minutes
Rapid Hardness Development (% of ultimate)	4 hours 25% 8 hours 35% 24 hours 60% 7 days 100% Force Cure 20 mins. @ 180°F
Sward Hardness	48
Abrasion Resistance, Taber Abraser, CS-17 Wheel, 1000 cycles, 1000g load	6 mg loss
Impact Resistance (Dir/Rev)	160/160 lb Pass
Composition	Aliphatic polyurethane emulsion with additives, catalysts, surfactants, pigments, resins and modifiers
Compatibility	May be applied over a wide variety of substrates and previous coatings (Confirm through testing prior to application.) Typical substrates include concrete, masonry, glazed brick and terra cotta, stone, wood, steel, aluminum and many latex, oil and epoxy-based coatings. Bonding Additive or Primer required for some substrates and exposures.
Colors, Finishes	Clear, White, Custom Colors Tint Bases may be tinted in-house by Edison Dealers to match 880-Color fan deck system. Gloss, Satin and Flat Finishes

* Values shown are for clear *UA-210H*

VARIOUS GRADES - TYPICAL PROPERTIES		
TYPE	Elongation	Tensile Strength
H	50-70%	7000 psi
A/G	50-70%	6000 psi
NCL	100-150%	6000 psi
E	300-400%	4500 psi
EE	400-600%	3500 psi
F	10-25%	2500 psi

SAFETY:

AQUATHANE products are low in odor, non-flammable, low VOC, and non-hazardous when used with adequate ventilation and when care is taken to avoid eye and prolonged skin contact.

LIMITATIONS:

AQUATHANE products are not intended for use in continuous submersion or continuous high humidity exposures. For continuous immersion/high humidity services, we recommend using *AQUEPOXY 250* immersion-grade waterborne epoxy coating system.

AQUATHANE products must not be applied at temperatures below 50°F(10°C), as improper or damaged films may result.



APPLICATION

1. Preparation: *AQUATHANE UA-210* is supplied ready to use, and is generally not thinned. Flatted formulas may be thinned by addition of 5-10% clean potable water, if necessary. Pigmented formulas should be thoroughly stirred before each use. Applications involving use of *Type G bonding additive* require addition of the additive as a second component just prior to application. Mixtures with *Type G* should be used within one day.

Surfaces should be dust free and clean. Remove all grease, oil and other contaminants and roughen previous coatings to the extent required to get good wetting of the substrate. Prior to large-scale application, particularly over plastics, questionable surfaces or previous coatings, apply an inconspicuous test area to confirm adhesion and compatibility. If adhesion is inadequate, consult

Edison Coatings, Inc. regarding use of an adhesion-promoting primer.

2. Application: Apply *AQUATHANE UA-210* at 200 - 400 sq. ft./gallon by brush, pad, roller or low pressure airless spray. Apply evenly and moderately, avoiding rundown or ponding. Avoid excessive agitation or pressure, and avoid whipping air into the product as this may generate foam. A second coat may be applied, if needed, at any time following through-drying of the first coat. Do not apply at temperatures below 50°F (10°C) or when temperatures may fall below 50°F before through-drying. **NOTE:** Lo-Temp Aquathane UA210E or EE may be applied at 40°F.

NOTE: Temperature, humidity and air movement all effect drying and curing times. When working at marginal conditions, allow sufficient extra dry and cure times to compensate.

On porous surfaces, *UA-210* generally will require 2 or more coats. Gloss may be increased by applying additional coatings as required for particular job conditions.

In anti-graffiti applications, sufficient material must be applied to build a continuous surface film. Generally two coats will be adequate, but deeply textured or highly porous surfaces may require additional coatings. Multiple coatings (three or more) may limit capacity of the coating to “breathe”, or transmit vapor.

On wood surfaces, *AQUATHANE UA-210* may exhibit slight grain-raising tendencies. For smoothest finish, sand lightly between first and second coats. On hardwood floors, cedar siding or other natural wood surfaces, staining may be desired prior to *AQUATHANE UA-210* application. While the product is compatible with many oil and waterborne stains following overnight drying, compatibility testing in an inconspicuous area is always recommended. Some highly porous or moisture-sensitive fiberboards or simulated wood products may require the use of a sealer/primer before application of *AQUATHANE UA-210*.

On steel, galvanized steel and aluminum surfaces, abrasive cleaning is required to remove rust, loose scale or other corrosion products. This is followed by application of corrosion-inhibiting, adhesion-promoting primer *AQUAPRIME 211*.

Over *350-Series* coatings and *#240 Primer*, base coats must be thoroughly dry before application.

3. Curing: *AQUATHANE UA-210* requires curing time before developing full traffic and chemical resistance. *Type A/G* Graffiti resistance roughly parallels strength development, indicated above. Protection of surfaces from vandalism for at least 24-48 hours following application is recommended when possible. Cure may

be accelerated by heating to 180°F for 20 minutes, following drying. Do not subject uncured films to heavy moisture or standing water.

4. Graffiti Maintenance: *AQUATHANE UA-210 Type A/G* is intended to withstand repeated cleanings before reapplication is required. Most markers and spray enamels can be removed using Xylene without damage to the *AQUATHANE* coating. If stronger removal is required, methyl ethyl ketone may be used. Proprietary cleaners should be tested before use. Some highly durable stains may require the use of a heavy duty paste paint remover. When using strong removal agents, some loss of gloss in the *AQUATHANE* film may occur. This may be restored by light reapplication in the affected areas. After repeated cleanings, if the film appears rough or uneven, it is time for application of an additional *AQUATHANE UA-210 Type A/G* seal coat.

CAUTION!: Many solvents and cleaners commonly used for removing graffiti are hazardous chemicals requiring special care in storage and handling. Refer to manufacturers’ Material Safety Data Sheets before using any chemical product.

5. Storage and Handling: KEEP FROM FREEZING. Keep container closed when not in use. Use with adequate ventilation. Avoid splashing into eyes or prolonged skin contact. Wash thoroughly after use. Clean tools and applicators immediately after use with warm water. Avoid depositing on shrubbery, windows, cars and other surfaces or property. In case of eye contact, flush with clean water for at least 15 minutes and consult physician. In case of ingestion, give water, do not induce vomiting. Keep out of reach of children. Observe all safety and handling guidelines as detailed in the Material Safety Data Sheets supplied with this product.

FOR COMMERCIAL AND INDUSTRIAL USE.



3 Northwest Drive, Plainville, CT 06062

Phone: (860) 747-2220 or (800) 697-8055

E-mail: edison@edisoncoatings.com

Fax: (860) 747-2280 or (800) 697-8044

Internet: www.edisoncoatings.com

Edison Coatings products are for commercial use only. In case of defect in manufacture or packaging, materials will be replaced at no cost. No other warranty, except for such replacement, express or implied, is in effect. Any implied warranty of merchantability or fitness for a particular purpose is expressly disclaimed. Although information and advice supplied in this publication are believed to be reliable, they do not represent performance specifications and no obligation or liability is assumed for advice given or results obtained. Product formulations and performance characteristics are subject to change without notice. Other conditions and limitations may be imposed at time of sale.

Silicone Sealants

Dow Corning[®] 790 Silicone Building Sealant

FEATURES

- Excellent performance even in building joints that experience extreme movement
- Suitable for new and remedial construction
- Extension/compression capability of +100/-50 percent

BENEFITS

- Excellent weathering properties and resistance to sunlight, rain, snow, and temperature extremes
- Excellent unprimed adhesion to masonry, concrete substrates
- Easy application over a wide temperature range

COMPOSITION

- Ultra-low-modulus, one-part, neutral-cure silicone sealant

Ultra-low-modulus sealant for new and remedial construction joint sealing applications

APPLICATIONS

Dow Corning[®] 790 Silicone Building Sealant offers outstanding unprimed adhesion to masonry and is particularly effective for sealing expansion and control joints, precast concrete panel joints, Exterior Insulation and Finish Systems (EIFS) joints, curtainwall joints, mullion joints, stone pavers, and many other construction joints. When used in accordance with Dow Corning application and testing recommendations, the sealant forms a durable, flexible, watertight bond with many common building materials, including combinations of stone, concrete, masonry, granite, marble, aluminum, painted substrates, and glass.

TYPICAL PROPERTIES

Specification Writers: Please contact your local Dow Corning Sales Application Engineer or Dow Corning Customer Service before writing specifications on this product.

Method	Test	Unit	Result
As Supplied			
ASTM C 679	Tack-Free Time, 50% RH	hours	1
	Curing Time, 50% RH, at 25°C (77°F), 3/8" depth	days	7-14
	Full Adhesion, cured joint	days	14-21
ASTM D 2202	Flow, Sag, or Slump		None
CTM ¹ 98 B	Working Time	minutes	10-20
EPA Method 24	VOC Content ² , maximum	g/L	43
As Cured – After 7 days at 25°C (77°F) and 50% RH			
ASTM C 661	Durometer Hardness, Shore A	points	15
ASTM D 412	Tensile Strength, maximum	psi (kg/mm ²)	100 (0.070)
ASTM C 794	Peel Strength	lb/in (kg/cm)	25 (4.46)
ASTM C 1135	Tensile, at 25% extension	psi (kg/mm ²)	15 (0.010)
	at 50% extension	psi (kg/mm ²)	20 (1.015)
ASTM C 719	Joint Movement Capabilities Extension/Compression	percent	+100/-50
ASTM C 1248	Staining, various substrates		None

¹CTMs (Corporate Test Methods) correspond to standard ASTM tests in most instances. Copies of CTMs are available upon request.

²Based on South Coast Air Quality Management District of California. Maximum VOC is listed both inclusive and exclusive of water and exempt compounds. For a VOC data sheet for a specific sealant color, please send your request to product.inquiry@dowcorning.com.

DESCRIPTION

Suitable for new construction or remedial applications, *Dow Corning* 790 Silicone Building Sealant provides excellent performance, even in building joints that experience extreme movement. It places a low stress on the sealant/substrate bond line to minimize failures in moving joints.

Dow Corning 790 Silicone Building Sealant is available in 11 colors: black, precast white, gray, natural stone, bronze, adobe tan, blue spruce, rustic brick, sandstone, charcoal, and dusty rose. Custom colors are available upon request.

APPROVALS/ SPECIFICATIONS

This sealant meets or exceeds the requirements of:

- ASTM Specification C 920, Type S, Grade NS, Class 100/50, Use T, NT, M, G, A, and O
- Many UL wall/floor fire designs, some without a protective cover plate (see www.ul.com for current listing)
- Fire Tests of Building Construction and Materials, UL 263 (ASTM E 119)

Data from an independent test lab and Sealant, Waterproofing and Restoration Institute validation are available from Dow Corning and the SWR Institute. A complete product specification sheet for this product is available upon request.

HOW TO USE

Consult the current version of the *Dow Corning Americas Technical Manual*, Form No. 62-1112, (available from www.dowcorning.com/construction) for detailed information on application methods, joint design, field testing, and warranty requirements when using *Dow Corning*[®] brand sealants. Please contact your local Dow Corning Sales Application Engineer for specific advice.

HANDLING PRECAUTIONS

PRODUCT SAFETY INFORMATION REQUIRED FOR SAFE USE IS NOT INCLUDED IN THIS DOCUMENT. BEFORE HANDLING, READ PRODUCT AND MATERIAL SAFETY

DATA SHEETS AND CONTAINER LABELS FOR SAFE USE, PHYSICAL AND HEALTH HAZARD INFORMATION. THE MATERIAL SAFETY DATA SHEET IS AVAILABLE ON THE DOW CORNING WEBSITE AT WWW.DOWCORNING.COM, OR FROM YOUR DOW CORNING SALES APPLICATION ENGINEER, OR DISTRIBUTOR, OR BY CALLING DOW CORNING CUSTOMER SERVICE.

USABLE LIFE AND STORAGE

When stored at or below 32°C (90°F), *Dow Corning* 790 Silicone Building Sealant has a shelf life of 12 months from date of manufacture. Refer to product packaging for "Use By" date.

PACKAGING

Dow Corning 790 Silicone Building Sealant is packaged in 10.3-fl oz (305-mL) disposable cartridges that fit ordinary caulking guns, 20-fl oz (590-mL) E-Z Pak foil sausages that fit caulking guns, and also in 2.0- and 4.5-gal (7.5- and 17-L) bulk pails. It can be dispensed by many air-operated guns and most types of bulk dispensing equipment.

LIMITATIONS

Dow Corning 790 Silicone Building Sealant should not be applied:

- In structural applications.
- Below grade or to materials that outgas, which can cause bubbling in curing sealant.
- On brass or copper or other similar material that can be corroded.
- To surfaces that are continuously immersed in water.
- For use as an interior penetration firestop sealing system.
- To building materials that bleed oils, plasticizers, or solvents – materials such as impregnated wood, oil-based caulks, green or partially vulcanized rubber gaskets, or tapes or bituminous below-grade waterproofing and asphalt-impregnated fiberboard.
- In totally confined spaces because the sealant requires atmospheric

moisture for cure.

- To surfaces that will be painted after application. The paint film will not stretch with the extension of the sealant and may crack and peel and most likely will not adhere to the sealant.
- To surfaces in direct or indirect contact with food.
- To wet or frost-laden surfaces.
- In applications where solvents or primers are not fully dried prior to sealant application. Uncured sealant is very sensitive to many solvents, primers, and cleaning agents; these may cause the sealant to remain uncured or tacky.

This product is neither tested nor represented as suitable for medical or pharmaceutical uses.

HEALTH AND ENVIRONMENTAL INFORMATION

To support customers in their product safety needs, Dow Corning has an extensive Product Stewardship organization and a team of Product Safety and Regulatory Compliance (PS&RC) specialists available in each area.

For further information, please see our website, www.dowcorning.com, or consult your local Dow Corning Sales Application Engineer.

LIMITED WARRANTY INFORMATION – PLEASE READ CAREFULLY

The information contained herein is offered in good faith and is believed to be accurate. However, because conditions and methods of use of our products are beyond our control, this information should not be used in substitution for customer's tests to ensure that Dow Corning's products are safe, effective, and fully satisfactory for the intended end use. Suggestions of use shall not be taken as inducements to infringe any patent.

Dow Corning's sole warranty is that the product will meet the Dow Corning sales specifications in effect at the time of shipment.



**SEALANT • WATERPROOFING
& RESTORATION INSTITUTE**

Issued to: **Dow Corning Corp.**
Product: **790 Silicone Building Sealant**

C719: Pass Ext:+100% Comp:-50%

Substrate: Mortar, Aluminum, Glass
[Dow Corning 1200 Primer used on aluminum substrates]

C661: Rating 15

Validation Date: 10/09/06 - 10/08/11

No. 1006-7901011 Copyright © 2006

SEALANT VALIDATION
www.swrionline.org

Your exclusive remedy for breach of such warranty is limited to refund of purchase price or replacement of any product shown to be other than as warranted.

**DOW CORNING SPECIFICALLY
DISCLAIMS ANY OTHER EXPRESS
OR IMPLIED WARRANTY OF FIT-
NESS FOR A PARTICULAR PUR-
POSE OR MERCHANTABILITY.**

**DOW CORNING DISCLAIMS LIA-
BILITY FOR ANY INCIDENTAL
OR CONSEQUENTIAL
DAMAGES.**

A 20-year Weatherseal Limited
Warranty is available. Some testing
may be required. Consult your
Dow Corning Sales Application
Engineer for details.

 Edison Coatings, Inc.

Custom SYSTEM 45

**Composite Repair Compounds for
Stone, Masonry & Concrete**



The Palladium Building, New Haven, CT, Listed, National Register of Historic Places, shown here 22 years after application of more than 16,000 lbs. of repair mortar, remains an ongoing testimonial to the exceptional durability, compatibility and aesthetics provided by Custom System 45.

Custom SYSTEM 45

Edison *Custom SYSTEM 45* products are two-component, latex-modified, cementitious compounds used to produce highly durable and compatible aesthetic repairs to masonry and concrete. They may also be used as stone-like finishes on a variety of other substrates.

Over the course of three decades of successful application on historic restoration projects, *Custom SYSTEM 45* masonry repair mortars have been matched to over three thousand different types and colors of natural stone, concrete and clay masonry. Ten distinct base formulas are used:

TYPE	SUBSTRATE
BL	BLUESTONE
BR	BRICK
CN	ARCHITECTURAL CONCRETE
GR	GRANITE
LC	LIMESTONE & CALCAREOUS CAST STONE
MR	MARBLE
SD	SILICEOUS SANDSTONE & BROWNSTONE
SL	SLATE
ST	PORTLAND CEMENT STUCCO
TC	TERRA COTTA & BRICK

For custom masonry repointing mortars, refer to the product data for *SPEC-JOINT 46*. For complete cement plaster replacement systems, refer to the product data sheet for *CEM-PLAST 54*. For natural cement systems, see *Rosendale Natural Cement Products*®.

In each case a mechanically compatible formulation is prepared, based on suitable aggregates of similar composition, color and gradation to the material being repaired. Final color adjustment is achieved, where required, using low levels of highly stable inorganic pigments and fillers.

Custom SYSTEM 45 has provided durable, inconspicuous repairs on a wide variety of structures, including churches, schools, monuments, post offices, courthouses, university buildings, hospitals, libraries, railroad stations, apartment buildings, hotels, office buildings and private residences.

RL-SERIES RESTORATION LATEXES

RL-1	STANDARD, TROWEL GRADE
RL-2	CASTING & COATING GRADE
RL-3	MARINE & IMMERSION GRADE
RL-4	HIGH PERMEABILITY GRADE
RL-5	HOT WEATHER GRADE
RL-6	COLD WEATHER GRADE

FEATURES:

Custom SYSTEM 45 has been formulated to provide an optimum balance of the most important performance properties. These include:

High Adhesive Bond Strength

High Dimensional Stability

Substrate-Specific Coefficient of Thermal Expansion

Low Modulus of Elasticity

Compatible Liquid and Moisture Vapor Permeability

Natural Appearance

Excellent Workability

All of these properties influence the long-term performance and compatibility of the repair with the substrate.

High Tensile Bond Strength (Adhesion)

Tenacious adhesion to all types of properly prepared concrete and masonry surfaces is a primary performance requirement for any repair material. High tensile bond strength is of primary importance, because the other performance properties are irrelevant if the product is no longer bonded to the substrate.

Custom SYSTEM 45 latex-modified cement-based mortars achieve higher direct tensile bond than the competitive unmodified mortars. Performance exceeds recommended minimum levels indicated in ICRI Guideline 03733, *Guide to Selecting and Specifying Concrete Repair Materials*.

Low Modulus of Elasticity ("Stiffness")

Of critical importance to the durability of masonry repair materials is the elimination of stress between the repair mortar and the host substrate. Materials which are low in modulus of elasticity (low in "stiffness") deform to relieve stress, as opposed to more rigid, higher modulus materials which may distress adjacent low strength substrates.

Custom SYSTEM 45 latex-modified mortars are able to achieve compressive strengths similar to the substrate being repaired while maintaining lower modulus than the host material. This assures that the repair mortar always behaves as the softer material,

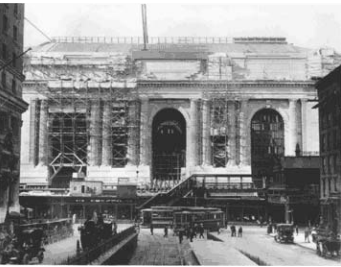

relieving stress and preventing damage or premature failure.

Appearance: Excellent aesthetic results are achieved, because color and texture are closely matched to the existing masonry. Repairs can be virtually indistinguishable from original work, and both accelerated weathering (ASTM G-53) and natural exposure testing assure long-term color retention. Formulations are UV-stable and non-yellowing.

Dimensional Stability: Practical field experience indicates that materials exhibiting high drying shrinkage are likely to crack and fail prematurely. *ICRI Guide #03733* encourages the use of materials with **low** shrinkage, which is defined as less than 0.05% drying shrinkage. **Custom SYSTEM 45** meets this requirement, without the use of expansive components or formation of ettringite to compensate for shrinkage. The result is low stress cure and crack free, durable repairs.

Consistency: **Custom SYSTEM 45** is more reliable and consistent in appearance and performance than competitive non-latex mortars or simple field-mixed mortars. Color, composition and quality are rigidly controlled in the manufacturing process, and critical ingredients are single-sourced to eliminate variations, even on projects extending over months or years and requiring many production batches. The two components are simply mixed together and applied, eliminating any influence by variations in local aggregate, cement or water compositions. Under most normal application conditions, proper curing and strength are achieved without special procedures or prolonged wet curing.

Permeability: **Custom SYSTEM 45's** latex-cement comatrix retains excellent **moisture vapor** permeability (>20 perms at 1/2" depth), avoiding moisture entrapment at the patch/substrate bond line. **Liquid moisture** permeability is comparable with substrate permeability, allowing repairs to meet the dual objectives of restoring building envelope integrity against moisture infiltration, while allowing internal moisture to escape harmlessly.

Thermal Expansion: Coefficient of thermal expansion for each grade of **Custom SYSTEM 45** is matched to expansion coefficients of the substrate, allowing long-term durability in exterior

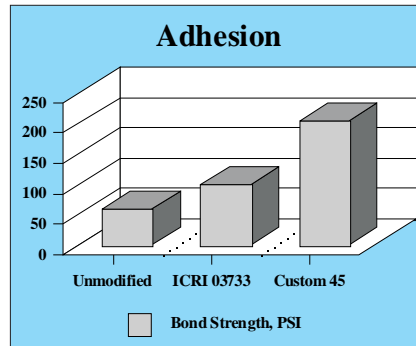

TYPICAL PERFORMANCE PROPERTIES		
Adhesion	Direct Tensile Bond	205 psi
	ASTM C1042	1320 psi
Modulus of Elasticity	ASTM C580	<1 x 10 ⁶ psi
Moisture Vapor Permeance	ASTM E96	12-23 perms @ 1/2" depth
Freeze Thaw Resistance	10 Years, Natural Exposure	No Scaling or Delamination
Drying Shrinkage	ASTM C157	<0.05% Low

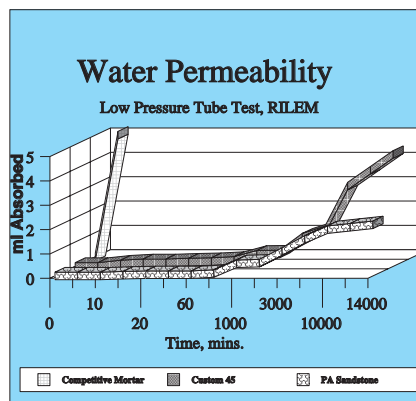
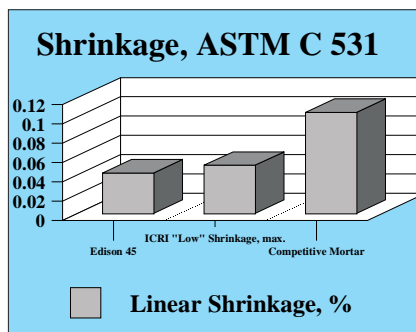

LINEAR COEFFICIENT OF THERMAL EXPANSION, IN./IN./°F x 10 ⁻⁶			
Substrate	45 Grade	Substrate Coefficient	Custom 45 Coefficient
Limestone/Calcareous	LC	2.5 - 6.7	5.1
Sandstone/Siliceous	SD	4.5 - 6.7	6.0
Terra Cotta, Brick	TC	~3	4.1
Marble	MR	3 - 5	4.7
Granite	GR	3 - 6	5.0
Concrete	CN	6 - 8	7.0

exposures which are subject to wide temperature variations.

Composition: Part "A" (Restoration Latex **RL-1**) is a unique, proprietary self-crosslinking acrylic emulsion. Part "B" is a cement-based blend of select graded aggregates, additives, fillers and pigments, with performance and workability-enhancing admixtures. No chlorides, added gypsum or corrosive or deleterious additives are used.

Workability: Products are formulated for excellent workability under a wide range of repair situations. Product is **not** formulated for fast set or rapid hardening, permitting fine tooling, carving, shaving, grooving or sculpting in the period following initial set. Standard non-sag consistency allows unsupported build-up of up to 2" on vertical surfaces without sagging, up to 1 inch on overhead applications. Optional **RL-2** superplasticized grade liquid allows material to be cast in forms without changing strength or color.

Constructability: **Custom SYSTEM 45** is "user-friendly". The product allows some adjustment in working consistency and supports a wide range of acceptable application and finishing methods. In most cases special curing is not required, assuring that satisfactory results are obtained under a wide variety of conditions.

Worker Training: Edison Coatings conducts "hands-on" training workshops on a regular basis. This **optional** course helps workers achieve optimum results with maximum efficiency. "On-Site" training is also available, to help entire crews achieve high-quality, cost-effective repairs and to address job-specific challenges. Current workshop schedules can be found on our web site "Calendar" page and additional information on "in-house" and "on-site" programs can be found on the "Training" page at www.edisoncoatings.com.

Safety: Products are non-corrosive, non-flammable, non-combustible and contain no toxic solvents, monomers or diluents. Low odor allows interior as well as exterior application. Powder components are formulated and graded to exclude toxic crystalline silica.

THE COLOR & GRADE SELECTION PROCESS

Custom SYSTEM 45 is available in 10 standard grades and over 3000 colors. Test kits and custom color matching services are available at nominal costs. For best results, send cleaned samples of

the substrate to be repaired to Edison Coatings, Inc. for free evaluation.

Edison Coatings regional dealers often stock the formulations most commonly used in their area. Call for the nearest stocking dealer location.

The following are key elements in successful color selection:

1. **Choose representative samples for matching.** Choose color on the basis of the actual range of colors on the building. Samples should be cleaned in the same manner, using the same cleaning agents that will be used for general building cleaning. Indicate the portion of the sample to be matched by circling the appropriate area, or by placing an "X" in a corner of the side to be matched.

2. **Use multiple colors.** Stone and masonry are often variable in color, and better overall match is often achieved through use of more than one color of *Custom SYSTEM 45*. Intermediate shades can be produced by blending light and dark shades of *Custom SYSTEM 45* in any proportion.

3. **Install test patches.** The most accurate way to evaluate visual compatibility is through in situ test patching. Allow adequate cure time before final evaluation. Initial color should be *darker* than the substrate.

APPLICATION:

1. **Surface Preparation:** Durable, effective repairs require clean, sound substrates. Remove all contaminants, coatings, efflorescence, unsound masonry and inappropriate previous repair mortars. If large or deep repairs will be otherwise unsupported, mechanical keying or anchoring is recommended. The decision to anchor should be based on structural requirements, the condition of the substrate, patch dimensions and weight, and the extent to which patch integrity will otherwise rely on adhesion alone. Such decisions and details concerning spacing and configuration are frequently best made in consultation with a qualified professional. Good restoration practice should always be observed.

2. **Application:** *Custom SYSTEM 45* may be applied by trowel, spray, casting-in-place or other commonly used repair techniques. **Note: Sponge floating is not recommended, as it introduces extra water and affects color.**

Standard latex component *RL-1* provides good hand workability under a variety of application methods and conditions. *RL-2* superplasticized liquid produces highly fluid consistencies, facilitating casting and coating without introducing extra liquid or changing color and strength. *RL-3* provides superior adhesion and durability for repairs subject to prolonged wet exposure or immersion. *RL-4* provides higher permeability for repairs subject to high humidity differentials or intermittent negative side moist exposures. *RL-5* is a hot weather grade, providing extended working life at temperatures above 85F. *RL-6* is a cold weather formulation, designed to accelerate initial set, to prevent disruption by freezing. Custom combinations of special properties (e.g. *RL2/6* superplasticized/cold weather) are also available.

a. **Priming:** For best adhesion, do not apply product to dry surfaces. Slurry coating is the preferred method of priming, using a thin brush coating of 1 part *Custom 45* liquid and 3 parts powder. For best results, apply patching mortar immediately after priming. Do not allow slurry coat to dry out before patching mortar placement.

b. **Mixing:** Best results are obtained when Part A and B are mixed together at consistent proportions. Determine the powder to liquid proportion which works and handles best for your particular application and *Custom SYSTEM 45* formulation, and then measure the same proportions for each mix. Mix ratios are generally between 5:1 and 7:1 by weight, or between 3 qts. (3 liters) and 5 quarts (5 liters) per 45-pound (20 kg) pail. Good results can also be obtained by thorough hand mixing. Do not mix more material than can be applied in about 15 minutes. Product will adhere and "hang" most efficiently if not mixed too wet.

c. **Cold Weather:** Minimum temperature for optimum color control is 50°F (10°C). While good mechanical results are obtained at temperatures above 40°F (4°C), color development tends to be lighter at low temperatures. For optimum color control, temperature must be above minimum at time of application, and must be maintained until product has dried thoroughly. Drying time may vary from an hour or two (thin patches, warm and dry weather) to overnight (deep



patches, cool and damp conditions). At temperatures below 50F (10 C), use of *RL-6* winter grade latex is recommended to accelerate curing.

Store *SYSTEM 45* components in a heated area until just before use. *Do not patch frozen surfaces.* Hot water rinsing of surfaces can help achieve minimum temperatures under marginal conditions. If auxiliary heating is used, do not direct hot exhaust gases at patches. Moderate temperatures and

air flows work best, and heated air is preferable to burner exhausts, which are high in CO and CO₂.

d. **Hot Weather:** Store materials in a cool place, out of direct sun. Dampen surfaces thoroughly with cold water prior to application to reduce suction and slow product drying. Do not thin excessively or retemper with additional liquid or water. To improve hot weather workability, shade work areas from direct sun, and use *Restoration Latex RL-5* to extend working time. Lightly mist surfaces or drape dampened burlap to allow a minimum of 2 hours' moisture after application. Over-thinned or rapidly-dried surfaces may develop plastic cracking shortly after application. Remove and replace any such cracked patches.

e. **Interruption:** If work will be interrupted due to drop width or other limitations, always try to work to an inconspicuous "break", such as a column line or ledge.

f. **Color Blending:** On masonry exhibiting unit-to-unit color variations, more than one custom color may be needed to achieve inconspicuous repairs. Generally, varied blends of patch colors are less conspicuous than a single, uniform repair color. Alternatively, an intermediate shade should be selected, and color shading can later be achieved using *EXPO 43* cement-based coating or *EverKote 300* mineral stain, which may be applied to all or part of the units which are repaired. To blend fresh patch appearance with weathered adjacent original materials, use *LiquidDirt 94*.

g. **Finishing & Carving:** Product set is not accelerated. Build material steadily, using a light sweeping stroke, and allowing material to "fatten" for several minutes between applications. Finishing times may be varied to suit the mechanic, and while some prefer to tool and finish immediately, while product remains in a plastic state, others prefer to wait until initial set, typically an hour or so after application. Product is easily shaved in this stage of hardening, but may be carved at any time after application. Some additional finishing is also possible the following day. **For very deep repairs,** consider forming and pouring full-depth in a single application using *Custom System 45* mixed with *RL-2 Restoration Latex*.

h. **Curing:** Product should be allowed to dry cure after a brief initial moist period. Do not steam clean or pressure wash patches which have not fully cured. Application in direct sun will produce temporarily robust colors, which will tone down to the "normal" color after a brief period of natural exposure. Color adjustment can also be achieved during cure by application of *SYSTEM 90-W-Color* or *EverKote 300*. *SYSTEM 90-W-Color* is also available in several translucent shades which simulate the patina of aging, to give repairs a more "weathered" appearance. For best long-term durability, *SYSTEM 90-W* can be applied to all masonry and patch surfaces.

3. **Storage & Handling:** Proper care should be taken when handling cement-based materials, to avoid skin and eye contact and avoid breathing dust. Some formulations contain free silica, and proper NIOSH-approved silica dust filters should be used. Products should be stored in a dry place, off the ground or floor, at moderate temperatures. KEEP FROM FREEZING. For complete safety and handling information, refer to Material Safety Data Sheets furnished with this product. Shelf life for properly stored material is minimum of 1 year from date of production.

FOR COMMERCIAL & INDUSTRIAL USE

Rev. 1/2010



3 Northwest Drive, Plainville, CT 06062

Phone: (860) 747-2220 or (800) 341-6621

E-mail: edison@edisoncoatings.com

Fax: (860) 747-2280 or (866) 658-1189

Internet: www.edisoncoatings.com

Edison Coatings products are for commercial use only. In case of defect in manufacture or packaging, materials will be replaced at no cost. No other warranty, except for such replacement, express or implied, is in effect. Any implied warranty of merchantability or fitness for a particular purpose is expressly disclaimed. Although information and advice supplied in this publication are believed to be reliable, they do not represent performance specifications and no obligation or liability is assumed for advice given or results obtained. Product formulations and performance characteristics are subject to change without notice. Other conditions and limitations may be imposed at time of sale.

THIN-FILL 55

THIN SECTION REPROFILING MORTAR

DESCRIPTION:

THIN-FILL 55 is a latex-modified reprofiling mortar for vertical and non-traffic bearing horizontal masonry and concrete surfaces. **THIN-FILL 55** allows application of thin-section patches of 1/32 to 1/8 inch depth while maintaining excellent adhesion, strength, breathability and resistance to cracking.

THIN-FILL 55 provides smooth finishes which can also be further polished to repair glazed terra cotta or polished stone profiles. Optional subsequent application of **Aquathane UA210 NCL** glaze replacement coating allows close duplication of existing terra cotta and stone finishes.

FEATURES:

- Ultra Fine texture for smooth finishing and thin-section repair
- Can be further polished with 400 Grit sandpaper to achieve near-glaze texture
- Tough, Durable, Breathable, Low Modulus
- Available in Standard Grey, White and Custom Colors
- Non-Silica fine aggregates used to avoid respirable toxic silica handling

APPLICATION:

1. Surface Preparation: Surfaces must be clean, rough, damp or dry, and free of form oil, curing compounds, grease, oil, dirt, efflorescence, coatings, or other materials which may hinder adhesion. Dampen surfaces with clean water or prime with a slightly thinned brush coat of THIN-FILL 55 before patching, but do not apply over standing or seeping water.

2. Mixing: While mixing, add latex **THIN-FILL 55**, and mix to a stiff pasty consistency. Mix approximately 1 gallon of liquid per 1/2-cubic foot bag. Mix for 4 minutes using low speed (250 rpm) drill mixer.



Where's the Repair? Glazed terra cotta spall, upper left corner, filled and smoothed using Thin-Fill 55 prior to glazing and speckling with Aquathane UA210 coatings, matched to original glaze colors. Project is an Historic school restoration in Charleston, SC.

TECHNICAL PROPERTIES:

Property	Standard	Result
Weather Resistance	ASTM G53	No Change, 500 hours
Bond Strength	Direct Tensile	150 psi min.
Drying Shrinkage	ASTM C157	<0.08%
Modulus of Elasticity	ASTM C580	<1.5 x 10 ⁶

3. Application: Mix only what will be applied within 20-40 minutes. Mixes should not be retempered by repeated latex or water addition. Apply using standard plastering tools, and work into surface profile to assure complete filling and bond. For patches over 1/4 inch depth use **Custom SYSTEM 45**.

Depending on weather and working conditions, material reaches initial set in 1-4 hours. Keep patches damp by misting with clean water after initial set, when working in hot, dry, windy conditions. Do **not** wet cure for more than 8 hours. Do not subject to water immersion. Finish after material reaches “thumbprint” hardness. Material may be sanded or polished after set.

MINIMUM APPLICATION TEMPERATURE: 45⁰ F (6⁰ C). Consider air, product, and surface temperatures when working near minimum temperatures.

Safety & Handling: CAUTION!! May contain free silica. Avoid breathing dust. Use NIOSH-approved toxic dust mask rated for silica. **Contains Portland cement-Alkaline material;** Avoid skin and eye contact. In case of eye contact flush with clean water for 15 minutes and consult physician. **Read and observe all safety and handling guidelines as detailed in the Material Safety Data Sheet supplied with this product.** Store in dry area, off floor.

FOR COMMERCIAL AND INDUSTRIAL USE ONLY



3 Northwest Drive, Plainville, CT 06062

Phone: (860) 747-2220 or (800) 697-8055

Fax: (860) 747-2280 or (800) 697-8044

E-mail: edison@edisoncoatings.com

Internet: www.edisoncoatings.com

Edison Coatings products are for commercial use only. In case of defect in manufacture or packaging, materials will be replaced at no cost. No other warranty, except for such replacement, express or implied, is in effect. Any implied warranty of merchantability or fitness for a particular purpose is expressly disclaimed. Although information and advice supplied in this publication are believed to be reliable, they do not represent performance specifications and no obligation or liability is assumed for advice given or results obtained. Product formulations and performance characteristics are subject to change without notice. Other conditions and limitations may be imposed at time of sale.