



SAN FRANCISCO PLANNING DEPARTMENT

Certificate of Appropriateness Case Report

HEARING DATE: APRIL 16, 2014

1650 Mission St.
Suite 400
San Francisco,
CA 94103-2479

Reception:
415.558.6378

Fax:
415.558.6409

Planning
Information:
415.558.6377

Filing Date: August 29, 2013
Case No.: **2013.1211A**
Project Address: **101 TOWNSEND STREET**
Historic Landmark: South End Landmark District
Zoning: MUO (Mixed-Use Office) Zoning District
105-F Height and Bulk District
Block/Lot: 3794/015
Applicant: Karl Danielson, Dahlin Group
5865 Owens Drive
Pleasanton, CA 94588
Staff Contact Richard Sucre - (415) 575-9108
richard.sucre@sfgov.org
Reviewed By Timothy Frye – (415) 575-6822
tim.frye@sfgov.org

PROPERTY DESCRIPTION

101 TOWNSEND STREET is a three-story, reinforced concrete former warehouse located on a rectangular lot (measuring approximately 90 ft x 141 ft) at the southwest corner of Townsend and 2nd Streets. Constructed in 1913 by engineer A. E. Hornlein, the existing building features a painted stucco and concrete exterior, steel-sash windows, a flat roof, and defined cornice.

PROJECT DESCRIPTION

The proposed project consists of exterior alterations including:

- **Ground Floor Storefront Alterations:** The project would replace an existing roll-up door and infilled storefront opening on 2nd Street with new glazed roll-up doors. In addition, the project would construct new steel canopies over the door openings on the Townsend and 2nd Street facades. Within the upper portion of these two door openings, the project would replace the existing non-historic glazing with new aluminum storefront windows. Along the Alley (south) façade, the project would replace the existing roll-up doors and windows with new aluminum-sash windows, louvers or glazed roll-up doors. Along the Alley façade, new work is contained within the existing window and door openings.
- **Window Replacement:** On the second and third floors, the project would replace the existing steel-sash windows (portions of which have been altered over time) with new compatible substitute aluminum-sash windows (Custom Windows Series 8300), which match the lite pattern and approximate profile of the original historic windows.

- **Removal of Non-Historic Elements:** The project would remove non-historic elements (former tenant signage, fire escapes, ducts and pipes) from the exterior facades, and would patch and repair the stucco/concrete exterior to match.
- **Repaint Exterior Façade:** The project would repaint the painted stucco and concrete exterior. The new proposed paint color includes brown tones and dark gray
- **Construction of a New Roof Deck & Rooftop Penthouses:** The project would construct a new roof deck (approximately 3,300 sq ft), which would feature two rooftop stair penthouses and a new elevator penthouse. The new stair penthouses would be setback more than 22-ft from the 2nd Street façade, and more than 15-ft from the Townsend Street façade. The new penthouses would be clad in corrugated metal and feature shed roofs.
- **New Mechanical Equipment:** The project would install new rooftop mechanical equipment towards the southwest corner of the existing roof. This new equipment would feature a low profile, and would consist of new HVAC condensers and other miscellaneous equipment.

The majority of the proposed work conforms to the scopes of work delegated to Department Staff for Administrative Certificate of Appropriateness review in HPC Motion No. 0181. However, the proposed rooftop penthouse does not fully conform to the scope of work delegated to Department Staff; thus, the proposed project requires a public hearing in front of the Historic Preservation Commission.

OTHER ACTIONS REQUIRED

Proposed work requires a Building Permit from the Department of Building Inspection (DBI).

COMPLIANCE WITH THE PLANNING CODE PROVISIONS

The proposed project is in compliance with all other provisions of the Planning Code.

APPLICABLE PRESERVATION STANDARDS

ARTICLE 10

Pursuant to Section 1006.2 of the Planning Code, unless exempt from the Certificate of Appropriateness requirements or delegated to Planning Department Preservation staff through the Administrative Certificate Appropriateness process, the Historic Preservation Commission is required to review any applications for the construction, alteration, removal, or demolition of any designated Landmark for which a City permit is required. Section 1006.6 states that in evaluating a request for a Certificate of Appropriateness for an individual landmark or a contributing building within a landmark district, the Historic Preservation Commission must find that the proposed work is in compliance with the *Secretary of the Interior's Standards for the Treatment of Historic Properties*, as well as the designating Ordinance and any applicable guidelines, local interpretations, bulletins, related appendices, or other policies.

THE SECRETARY OF THE INTERIOR'S STANDARDS FOR REHABILITATION

Rehabilitation is the act or process of making possible a compatible use for a property through repair, alterations, and additions while preserving those portions or features that convey its historical, cultural, or architectural values. The Rehabilitation Standards provide, in relevant part(s):

Standard 1: A property shall be used for its historic purpose or be placed in a new use that requires minimal change to the defining characteristics of the building and its site and environment.

The proposed project does not include a change in use. Therefore, the proposed project complies with Rehabilitation Standard 1.

Standard 2: The historic character of a property shall be retained and preserved. The removal of historic materials or alteration of features and spaces that characterize a property shall be avoided.

The proposed project maintains the historic character of the subject property, as defined by its character-defining features, including, but not limited to, the overall mass and form, windows, and stucco/concrete exterior. The project assists in reinforcing the building's historic character by removing non-historic features from the exterior facades, including former tenant signage, a fire escape, ducts and pipes. Overall, the project reinforces the district's industrial character by introducing new elements, which are compatible with the district's industrial aesthetic. The proposed project does not call for the removal of historic materials or features. The proposed window replacement program introduces a new compatible substitute window material that is consistent with the industrial character of the surrounding landmark district, while also matching the existing design and profile of the existing historic windows. Further, the window replacement program assists in rectifying incompatible alterations to the windows, which have occurred over time, thus providing for a more consistent view of the exterior windows. On the exterior façade, the new elements, such as the glazed roll-up door and new steel canopy, are compatible in style, yet differentiated, and do not disrupt the building's historic character. Finally, the new rooftop elements are minimally visible from public rights-of-way, thus do not interfere with a reading of the building's historic elements. Therefore, the proposed project complies with Rehabilitation Standard 2.

Standard 3: Each property will be recognized as a physical record of its time, place and use. Changes that create a false sense of historical development, such as adding conjectural features or architectural elements from other buildings, shall not be undertaken.

The proposed project does not include the addition of conjectural elements or architectural features from other buildings. New work is contemporary and compatible in style, as evidenced by the steel canopies and glazed roll-up doors. The new work would not create a false sense of historical development and would be compatible with the surrounding district. Therefore, the proposed project complies with Rehabilitation Standard 3.

Standard 4: Most properties change over time; those changes that have acquired historic significance in their own right shall be retained and preserved.

The proposed project does not involve alterations to the subject building, which have acquired significance in their own right. The existing non-historic elements on the exterior (signage, fire escape, ducts and pipes) are not historic features, nor character-defining features of the landmark district. Therefore, the proposed project complies with Rehabilitation Standard 4.

Standard 5: Distinctive features, finishes, and construction techniques or examples of fine craftsmanship that characterize a property will be preserved.

The proposed project maintains and preserves the subject property's distinctive finishes and character-defining features, including the overall mass and form, windows, and stucco/concrete exterior. The project provides a compatible substitute window replacement program for the historic steel-sash windows, which are deteriorated. This new work would match the design, dimension and profile of the existing historic windows, while introducing energy-efficient and a new compatible material, thus preserving the design and style of the windows. Therefore, the proposed project complies with Rehabilitation Standard 5.

Standard 6: Deteriorated historic features will be repaired rather than replaced. Where the severity of deterioration requires replacements of a distinctive feature, the new feature will match the old in design, color, texture and other visual qualities and, where possible, materials. Replacement of missing features shall be substantiated by documentary, physical, or pictorial evidence.

The proposed project calls for the replacement of the steel-sash windows on the second and third floors with a new compatible, aluminum-frame, insulated glass window system (Custom Windows Series 8300) that will closely match the original in pane configuration, muntin profile, and general proportions.

Based upon a site visit and review of the existing windows documented by the Project Architect, Department staff concur that the majority of existing windows are beyond repair and exhibit steel corrosion, broken window panes, and warping of the steel frames, as well as incompatible alterations, whereby portions of the steel-sash windows have been replaced with new plate glass windows, new aluminum casement windows or air conditioning units. Where character-defining features are deteriorated beyond repair, the Secretary of the Interior's Standards for Rehabilitation (Secretary's Standards) allow for replacement in-kind or with a compatible substitute material.

The proposed replacement window system appears to constitute a compatible substitute in conformance with the Secretary's Standards. This system matches the historic windows in design, color and visual quality. The project sponsor has submitted appropriate documentation to record the condition of these windows, and has provided detailed information on the new window system, its profiles, and overall design. Therefore, the proposed project complies with Rehabilitation Standard 6.

Standard 7: Chemical or physical treatments, such as sandblasting, that cause damage to historic materials shall not be used. The surface cleaning of structures, if appropriate, shall be undertaken using the gentlest means possible.

The proposed project does not involve chemical or physical treatments. The project would repaint the existing painted stucco and concrete exterior. The proposed brown and gray colors would be consistent with the surrounding landmark district. Therefore, the proposed project complies with Rehabilitation Standard 7.

Standard 8: Significant archaeological resources affected by a project shall be protected and preserved. If such resources must be disturbed, mitigation measures will be undertaken.

The proposed project includes limited excavation. Appropriate mitigation measures will be undertaken to ensure that any uncovered archaeological resources are protected and preserved. Therefore, the proposed project complies with Rehabilitation Standard 8.

Standard 9: New additions, exterior alterations, or related new construction will not destroy historic materials, features, and spatial relationships that characterize the property. The new work will be differentiated from the old and will be compatible with the historic materials, features, size, scale and proportion, and massing to protect the integrity of the property and its environment.

The proposed project includes exterior alterations to the subject property, including ground floor storefront alterations, construction of new canopies over the ground floor entrances, replacement of the existing windows on the second and third floors, and construction of a new roof deck and rooftop stair/elevator penthouses.

On the ground floor, the project would introduce new glazed roll-up doors within the existing loading dock openings and within an infilled storefront along 2nd Street. The project would retain character-defining aspects of the loading dock openings, including the corner guards and bumpers. The new glazed roll-up doors are consistent and compatible, yet differentiated, with the typical metal roll-up doors within the surrounding landmark district, since the design is similar to these doors, while introducing a glazed element within the garage door. In addition to these doors, the project also includes construction of new steel canopies over the entryways on 2nd and Townsend Streets. In general, this new work is sufficiently differentiated from the historic building via its design, but is compatible in size, scale, material with the surrounding landmark district, since the new steel canopies evoke an industrial aesthetic, which is compatible with the area's industrial history.

On the upper floors, the project's window replacement program calls for a compatible substitute window system, which mirrors the design and profile of the historic multi-light steel-sash windows in a substitute material (aluminum). Overall, the window replacement program reinforces the building's historic character by re-introducing the historic multi-lite window

pattern in a consistent manner on the upper floors. The new windows would feature a similar sash profile, as the existing historic windows.

The new roof deck does not impact the historic character of the subject property, since it would not be visible from the public rights-of-way due to its setback from the building edge and the height of the building's parapet, which would obscure the roof deck and guardrail from public view. The new roof deck features a metal guardrail, which is consistent with the industrial aesthetic of the former industrial building.

Similarly, the new rooftop stair and elevator penthouses would be minimally visible from the public rights-of-way. The new penthouses are setback from the building edges and feature a sloped roof, so as to minimize its visibility. The new penthouses would not conflict with the existing building's form and massing, since it would be minimally visible and would not impact any significant historic characteristics of the subject property. The corrugated metal cladding of the new rooftop penthouse evokes with the industrial aesthetic found within the surrounding district, thus is compatible with the district's overall material palette.

Overall, the proposed project maintains the historic integrity of the subject property and provides new additions and features, which are compatible, yet differentiated from the landmark district. Therefore, the proposed project complies with Rehabilitation Standard 9.

Standard 10: New additions and adjacent or related new construction shall be undertaken in such a manner that if removed in the future, the essential form and integrity of the historic property and its environment would be unimpaired.

The proposed project includes construction of a roof deck and rooftop stair penthouse. These features may be removed in the future without impacting the essential form and integrity of the landmark. Further, these features do not impact any character-defining features of the subject property. Therefore, the proposed project complies with Rehabilitation Standard 10.

Summary: The Department finds that the overall project is consistent with the *Secretary of the Interior Standards for Rehabilitation*.

PUBLIC/NEIGHBORHOOD INPUT

As of April 9, 2014, the Department has received two public inquiries into the proposed project; however, these inquiries have expressed neither support nor opposition to the proposed. These inquiries have primarily focused on understanding the proposed project.

STAFF ANALYSIS

Included as an exhibit are architectural drawings of the existing building and the proposed project. Based on the requirements of Article 10 and the *Secretary of Interior's Standards*, Department staff has determined the following:

Appendix I to Article 10 – South End Landmark District: Appendix I of Article 10 of the San Francisco Planning Code identifies existing features and standards for review for alterations within the South End Landmark District. In particular, Section 6 of Appendix I identifies existing features, including:

1. *Overall Form and Continuity.* Building height is generally within a six-story range, and many of the oldest structures are one or two stories in height.
2. *Scale and Proportion.* The buildings are of typical warehouse design, large in bulk, often with large arches and openings originally designed for easy vehicular access. There is a regularity of overall form. The earlier brick structures blend easily with the scaled-down Beaux Arts forms of the turn of the century and the plain reinforced concrete structures characteristic of twentieth-century industrial architecture.
3. *Fenestration.* The earliest structures have few windows, expressing their warehouse function. They are varied in size, rhythmically spaced, deeply recessed, produce a strong shadow line, and relate in shape and proportion to those in nearby buildings. Larger industrial sash windows began to be incorporated in structures built from the 1920s and onward. Door openings are often massive to facilitate easy access of bulk materials.
4. *Materials.* Standard brick masonry is predominant for the oldest buildings in the district, with reinforced concrete introduced after the 1906 fire, although its widespread use did not occur until the 1920s. Brick and stone paving treatments on Federal and First and De Boom Streets respectively are extant as well as Beltline Railroad Tracks which run throughout the District.
5. *Color.* Red brick is typical, with some yellow and painted brick. Muted earth tones predominate in shades of red, brown, green, gray and blue.
6. *Texture.* Typical facing materials give a rough textured appearance. The overall texture of the facades is rough grained.
7. *Detail.* Arches are common at the ground floor, and are frequently repeated on upper floors. Flattened arches for window treatment are typical. Cornices are simple and generally tend to be abstract versions of the more elaborate cornices found in downtown commercial structures from the nineteenth century. Most of the surfaces of the later buildings are plain and simple reflecting their function. Some of the earlier brick work contains suggestions of pilasters, again highly abstracted. Where detail occurs, it is often found surrounding entryways.

Department staff has reviewed the proposed alterations for compatibility with these existing features, and finds that these alterations are consistent and compatible with the South End Landmark District, and the *Secretary of the Interior's Standards for Rehabilitation* (see above). The proposed project does not impact the overall form, continuity, scale or proportion of the existing building. The project maintains the building's fenestration pattern by reintroducing the historic multi-lite industrial sash pattern within all of the window openings on the second and third floors. The project maintains the texture of the stucco and concrete exterior, and would repaint the exterior in a muted earth (brown and gray). Finally, the project would maintain important exterior details, including the simple cornice and belt courses.

Ground Floor Alterations: The proposed project includes installation of new glazed roll-up doors on the ground floor and construction of new steel canopies over the entryways located along 2nd and Townsend Streets. Overall, these alterations introduce new elements on the ground floor, which serve to reinforce the building's overall historic character by providing for compatible, yet contemporary features, as evidenced by the glazing in the roll-up door and the design of the projecting steel canopies. These ground floor alterations would comply with the Secretary of the Interior's Standards for Rehabilitation and the requirements of Article 10 of the San Francisco Planning Code, since these alterations would introduce compatible, yet differentiated, exterior elements, which evoke the district's industrial aesthetic in a contemporary manner.

Exterior Painting & Removal of Non-Historic Elements: The project would repaint the painted stucco and concrete exterior and remove non-historic elements from the exterior facades, including former tenant signage, a fire escape, ducts and pipes. The project calls for repair and patching of any damaged stucco or concrete. This aspect of the project reinforces the building's contribution to the surrounding historic district by removing incompatible alterations (such as the exterior ducts) and repainting the building to better fit within the district's color palette. Currently, the exterior already features a painted finish over the stucco and concrete. This aspect of the project would comply with the Secretary of the Interior's Standards for Rehabilitation and the requirements of Article 10 of the San Francisco Planning Code

Window Replacement: The proposed project includes replacement of the existing multi-lite, steel-sash windows on the second and third floors with new multi-lite industrial-sash aluminum windows. As previously noted, the new aluminum-sash window system is considered an acceptable and compatible substitute window system, since the new windows would match the design, profile, and shape of the existing historic steel-sash windows. These alterations would comply with the Secretary of the Interior's Standards for Rehabilitation and the requirements of Article 10 of the San Francisco Planning Code, since the new aluminum window system is considered a compatible substitute material, would maintain and restore the exterior window pattern, and the new work would be compatible the surrounding landmark district. To ensure that the window profile is consistent with existing historic windows, the Department has included a condition of approval specifying a "T"-profile for the aluminum-sash cap.

Roof Deck, Rooftop Penthouse & Rooftop Mechanical Equipment: The proposed project would construct a new roof deck, new stair and elevator penthouses, and install new rooftop mechanical equipment. The new stair and elevator penthouses would be setback more than 22-ft from the 2nd Street façade, and more than 15-ft from the Townsend Street façade. These new features would not impact any of the existing character-defining features of the subject property and would be additive in nature. These new features would occur on the roof of the subject property and would be minimally visible from any public rights-of-way. The new features are setback from the building edge and are relatively small in scale. The location and sloped roof of the stair penthouse reduces its visibility, so that it is barely perceptible from the public rights-of-way. The new penthouse is clad in corrugated, which is a material commonly found on penthouses within the landmark district. Therefore, the new roof deck, stair penthouses, and mechanical equipment would comply with the Secretary of the Interior's Standards for Rehabilitation and the requirements of Article 10 of the San Francisco Planning Code, since this new work would be compatible with the historic building. To ensure that the cladding of the penthouse is

consistent with overall landmark, the Department has included a condition of approval to review the proposed materials and finish of the penthouse.

Summary: Department staff finds that proposed work will be in conformance with the Secretary's Standards and requirements of Article 10, as the proposed work shall not adversely affect the special character or special historical, architectural, or aesthetic interest or value of the landmark and its site.

ENVIRONMENTAL REVIEW STATUS

The Project is exempt from the California Environmental Quality Act ("CEQA") as a Class 1 and Class 31 Categorical Exemption (CEQA Guideline Section 15301 and 15331) because the project involves exterior and interior alterations to an existing building and meets the *Secretary of the Interior's Standards for Rehabilitation*.

PLANNING DEPARTMENT RECOMMENDATION

Planning Department staff recommends APPROVAL WITH CONDITIONS of the proposed project as it appears to meet the *Secretary of the Interior Standards for Rehabilitation* and requirements of Article 10.

CONDITIONS OF APPROVAL

To ensure that the proposed work is undertaken in conformance with this Certificate of Appropriateness, staff recommends the following conditions:

1. Prior to approval of the Site Permit, the Project Sponsor shall provide material samples, including examples of the corrugated metal (for the rooftop penthouses) and aluminum-sash multi-lite windows, to ensure compatibility with the surrounding landmark district. These material samples shall demonstrate the range of color, texture and finish for the identified materials. Generally, the materials should feature a matte or painted finish, and be consistent with the building's overall historic character.
2. Prior to approval of the Site Permit, the Project Sponsor shall specify a "T"-Profile for the aluminum-sash cap facing the exterior. The "T"-Profile matches the profile of the existing industrial steel-sash windows, and would be the most historically-accurate sash profile.

ATTACHMENTS

Draft Motion

Exhibits, including Parcel Map, Sanborn Map, Zoning Map, Aerial Photos, and Site Photos

Architectural Drawings

RS: G:\Documents\Certificate of Appropriateness\2013.1211A 101 Townsend St\CofA Case Report_101 Townsend St.doc



SAN FRANCISCO PLANNING DEPARTMENT

Historic Preservation Commission Motion No. XXXX

HEARING DATE: APRIL 16, 2014

1650 Mission St.
Suite 400
San Francisco,
CA 94103-2479

Reception:
415.558.6378

Fax:
415.558.6409

Planning
Information:
415.558.6377

Filing Date: August 29, 2013
Case No.: **2013.1211A**
Project Address: **101 TOWNSEND STREET**
Historic Landmark: South End Landmark District
Zoning: MUO (Mixed-Use Office) Zoning District
105-F Height and Bulk District
Block/Lot: 3794/015
Applicant: Karl Danielson, Dahlin Group
5865 Owens Drive
Pleasanton, CA 94588
Staff Contact Richard Sucre - (415) 575-9108
richard.sucre@sfgov.org
Reviewed By Timothy Frye - (415) 575-6822
tim.frye@sfgov.org

ADOPTING FINDINGS FOR A CERTIFICATE OF APPROPRIATENESS FOR PROPOSED WORK DETERMINED TO BE APPROPRIATE FOR AND CONSISTENT WITH THE PURPOSES OF ARTICLE 10, TO MEET THE STANDARDS OF ARTICLE 10 AND TO MEET THE SECRETARY OF INTERIOR'S STANDARDS FOR REHABILITATION, FOR THE PROPERTY LOCATED ON LOT 036A IN ASSESSOR'S BLOCK 3607, WITHIN THE LIBERTY-HILL LANDMARK DISTRICT, RH-3 (RESIDENTIAL, HOUSE, THREE-FAMILY) ZONING DISTRICT AND 40-X HEIGHT AND BULK DISTRICT.

PREAMBLE

WHEREAS, on August 29, 2013, Karl Danielson of the Dahlin Group (Project Sponsor) on behalf of Civitas Equity Fund I, LLC (Property Owners), filed an application with the San Francisco Planning Department (Department) for a Certificate of Appropriateness for exterior alterations and a new roof deck to the subject property located on Lot 015 in Assessor's Block 3794.

WHEREAS, the Project received an exemption from the California Environmental Quality Act ("CEQA") as a Class 1 and Class 32 Categorical Exemption (CEQA Guideline Sections 15301 and 15332) on April 9, 2014.

WHEREAS, on April 16, 2014, the Commission conducted a duly noticed public hearing on the current project, Case No. 2013.1211A (Project) for its appropriateness.

WHEREAS, in reviewing the Application, the Commission has had available for its review and consideration case reports, plans, and other materials pertaining to the Project contained in the

Department's case files, has reviewed and heard testimony and received materials from interested parties during the public hearing on the Project.

MOVED, that the Commission hereby grants with conditions a Certificate of Appropriateness, in conformance with the project information dated February 13, 2014 and labeled Exhibit A on file in the docket for Case No. 2013.1211A based on the following findings:

CONDITIONS OF APPROVAL

To ensure that the proposed work is undertaken in conformance with this Certificate of Appropriateness, staff recommends the following conditions:

1. Prior to approval of the Site Permit, the Project Sponsor shall provide material samples, including examples of the corrugated metal (for the rooftop penthouses) and aluminum-sash multi-lite windows, to ensure compatibility with the surrounding landmark district. These material samples shall demonstrate the range of color, texture and finish for the identified materials. Generally, the materials should feature a matte or painted finish, and be consistent with the building's overall historic character.
2. Prior to approval of the Site Permit, the Project Sponsor shall specify a "T"-Profile for the aluminum-sash cap facing the exterior. The "T"-Profile matches the profile of the existing industrial steel-sash windows, and would be the most historically-accurate sash profile.

FINDINGS

Having reviewed all the materials identified in the recitals above and having heard oral testimony and arguments, this Commission finds, concludes, and determines as follows:

1. The above recitals are accurate and also constitute findings of the Commission.
2. Findings pursuant to Article 10:

The Historic Preservation Commission has determined that the proposed work is compatible with the character of the South End Landmark District as described in Appendix I of Article 10 of the Planning Code.

- That the proposed project features façade alterations and additions, which are compatible with the South Landmark District, since these alterations and additions maintain the historic mass and form of the existing building, do not destroy historic materials, and provide for new construction, which is compatible, yet differentiated.
- That the proposed project maintains the historic character of the subject property, as defined by its character-defining features, including, but not limited to, its overall mass and form, windows, and cornice, as well as, other elements identified in the designating ordinance for South End Landmark District.

- That the proposed window replacement program identifies a compatible substitute material, which maintains the historic design, form, and sash profile of the historic windows.
- That the essential form and integrity of the landmark and its environment would be unimpaired if the alterations were removed at a future date.
- That the proposal respects the character-defining features of South End Landmark District.
- The proposed project meets the requirements of Article 10.
- The proposed project meets the *Secretary of the Interior's Standards for Rehabilitation*, including:

Standard 2.

The historic character of a property shall be retained and preserved. The removal of historic materials or alteration of features and spaces that characterize a property shall be avoided.

Standard 6.

Deteriorated historic features will be repaired rather than replaced. Where the severity of deterioration requires replacements of a distinctive feature, the new feature will match the old in design, color, texture and other visual qualities and, where possible, materials. Replacement of missing features shall be substantiated by documentary, physical, or pictorial evidence.

Standard 9.

New additions, exterior alterations, or related new construction will not destroy historic materials, features, and spatial relationships that characterize the property. The new work will be differentiated from the old and will be compatible with the historic materials, features, size, scale and proportion, and massing to protect the integrity of the property and its environment.

Standard 10:

New additions and adjacent or related new construction shall be undertaken in such a manner that if removed in the future, the essential form and integrity of the historic property and its environment would be unimpaired.

3. **General Plan Compliance.** The proposed Certificate of Appropriateness is, on balance, consistent with the following Objectives and Policies of the General Plan:

I. URBAN DESIGN ELEMENT

THE URBAN DESIGN ELEMENT CONCERNS THE PHYSICAL CHARACTER AND ORDER OF THE CITY, AND THE RELATIONSHIP BETWEEN PEOPLE AND THEIR ENVIRONMENT.

GOALS

The Urban Design Element is concerned both with development and with preservation. It is a concerted effort to recognize the positive attributes of the city, to enhance and conserve those attributes, and to improve the living environment where it is less than satisfactory. The Plan is a definition of quality, a definition based upon human needs.

OBJECTIVE 1

EMPHASIS OF THE CHARACTERISTIC PATTERN WHICH GIVES TO THE CITY AND ITS NEIGHBORHOODS AN IMAGE, A SENSE OF PURPOSE, AND A MEANS OF ORIENTATION.

POLICY 1.3

Recognize that buildings, when seen together, produce a total effect that characterizes the city and its districts.

OBJECTIVE 2

CONSERVATION OF RESOURCES WHICH PROVIDE A SENSE OF NATURE, CONTINUITY WITH THE PAST, AND FREEDOM FROM OVERCROWDING.

POLICY 2.4

Preserve notable landmarks and areas of historic, architectural or aesthetic value, and promote the preservation of other buildings and features that provide continuity with past development.

POLICY 2.5

Use care in remodeling of older buildings, in order to enhance rather than weaken the original character of such buildings.

POLICY 2.7

Recognize and protect outstanding and unique areas that contribute in an extraordinary degree to San Francisco's visual form and character.

The goal of a Certificate of Appropriateness is to provide additional oversight for buildings and districts that are architecturally or culturally significant to the City in order to protect the qualities that are associated with that significance.

The proposed project qualifies for a Certificate of Appropriateness and therefore furthers these policies and objectives by maintaining and preserving the character-defining features of the South End Landmark District for the future enjoyment and education of San Francisco residents and visitors.

4. The proposed project is generally consistent with the eight General Plan priority policies set forth in Section 101.1 in that:

- A) The existing neighborhood-serving retail uses will be preserved and enhanced and future opportunities for resident employment in and ownership of such businesses will be enhanced:

The project will not have any impact on any existing neighborhood serving retail uses, since there are no retail uses located on the project site.

- B) The existing housing and neighborhood character will be conserved and protected in order to preserve the cultural and economic diversity of our neighborhoods:

The proposed project would not impact any existing housing, and will strengthen neighborhood character by respecting the character-defining features of South-End Landmark District in conformance with the Secretary of the Interior's Standards for Rehabilitation.

- C) The City's supply of affordable housing will be preserved and enhanced:

The project will have no impact upon affordable housing, since there are no identified affordable housing units on the project site.

- D) The commuter traffic will not impede MUNI transit service or overburden our streets or neighborhood parking:

The proposed project will not result in commuter traffic impeding MUNI transit service or overburdening the streets or neighborhood parking. The proposed project is located within a transit-rich neighborhood with walkable access to bus, light rail and train lines.

- E) A diverse economic base will be maintained by protecting our industrial and service sectors from displacement due to commercial office development. And future opportunities for resident employment and ownership in these sectors will be enhanced:

The proposed will not have any impact on industrial and service sector jobs, since there is no active commercial uses on the project site.

- F) The City will achieve the greatest possible preparedness to protect against injury and loss of life in an earthquake.

Preparedness against injury and loss of life in an earthquake is unaffected by the proposed work. Any construction or alteration associated with the project will be executed in compliance with all applicable construction and safety measures.

- G) That landmark and historic buildings will be preserved:

The project as proposed is in conformance with Article 10 of the Planning Code and the Secretary of the Interior's Standards for Rehabilitation.

- H) Parks and open space and their access to sunlight and vistas will be protected from development:

The proposed project will not impact the access to sunlight or vistas for parks and open space.

5. For these reasons, the proposal overall, is appropriate for and consistent with the purposes of Article 10, meets the standards of Article 10, and the *Secretary of Interior's Standards for Rehabilitation*, General Plan and Prop M findings of the Planning Code.

DECISION

That based upon the Record, the submissions by the Applicant, the staff of the Department and other interested parties, the oral testimony presented to this Commission at the public hearings, and all other written materials submitted by all parties, the Commission hereby **GRANTS WITH CONDITIONS a Certificate of Appropriateness** for the property located at Lot 015 in Assessor's Block 3794 for proposed work in conformance with the project information dated February 13, 2014, labeled Exhibit A on file in the docket for Case No. 2013.1211A.

APPEAL AND EFFECTIVE DATE OF MOTION: The Commission's decision on a Certificate of Appropriateness shall be final unless appealed within thirty (30) days. Any appeal shall be made to the Board of Appeals, unless the proposed project requires Board of Supervisors approval or is appealed to the Board of Supervisors, such as a conditional use, in which case any appeal shall be made to the Board of Supervisors (see Charter Section 4.135).

Duration of this Certificate of Appropriateness: This Certificate of Appropriateness is issued pursuant to Article 10 of the Planning Code and is valid for a period of three (3) years from the effective date of approval by the Historic Preservation Commission. The authorization and right vested by virtue of this action shall be deemed void and canceled if, within 3 years of the date of this Motion, a site permit or building permit for the Project has not been secured by Project Sponsor.

THIS IS NOT A PERMIT TO COMMENCE ANY WORK OR CHANGE OF OCCUPANCY UNLESS NO BUILDING PERMIT IS REQUIRED. PERMITS FROM THE DEPARTMENT OF BUILDING INSPECTION (and any other appropriate agencies) MUST BE SECURED BEFORE WORK IS STARTED OR OCCUPANCY IS CHANGED.

I hereby certify that the Historic Preservation Commission ADOPTED the foregoing Motion on April 16, 2014.

Jonas P. Ionin
Commission Secretary

AYES:

NAYS:

ABSENT:

ADOPTED: April 16, 2014

Parcel Map

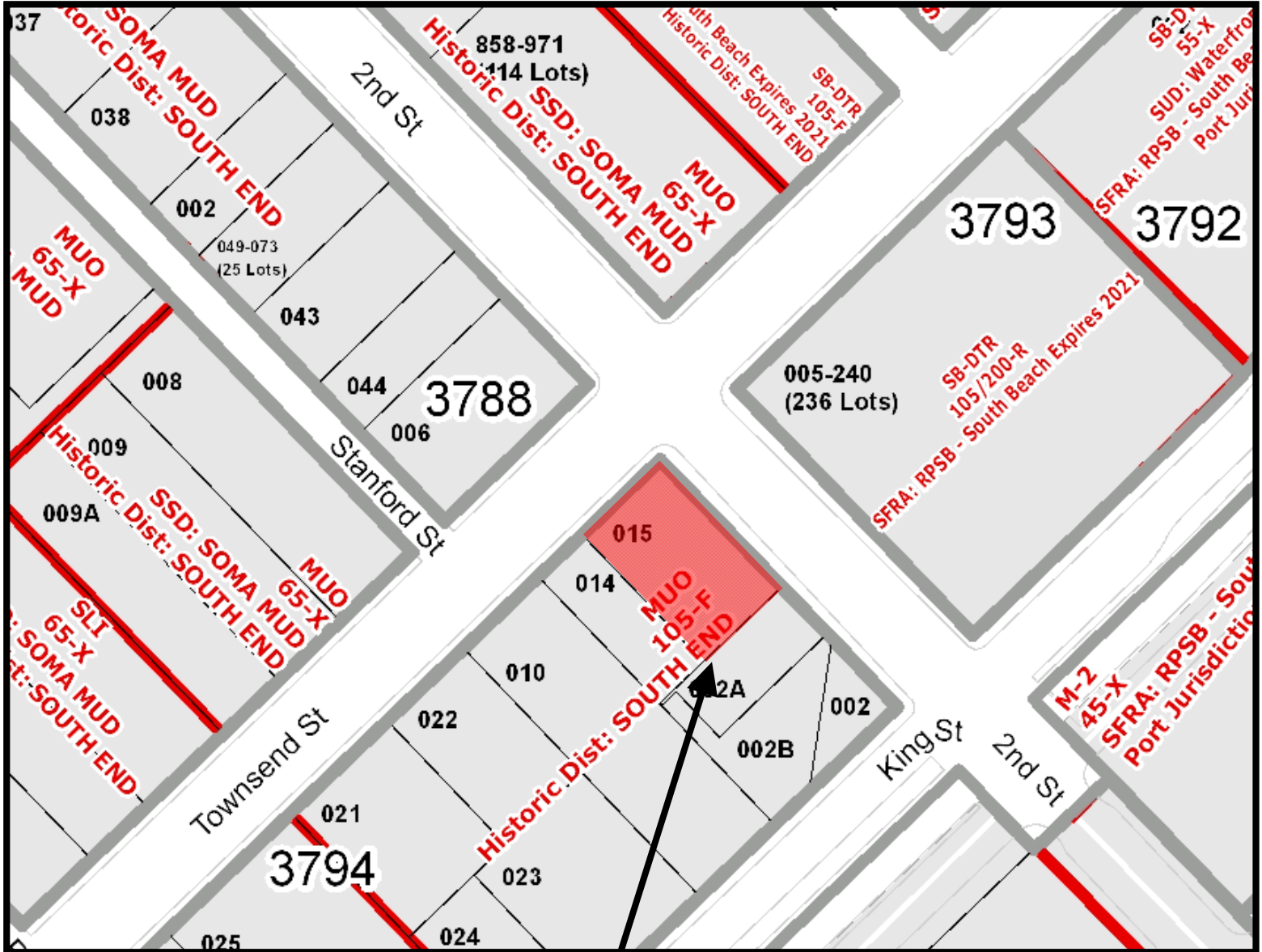

SUBJECT PROPERTY



Certificate of Appropriateness Hearing
Case Number 2013.1211A
101 Townsend Street

Sanborn Map*

SUBJECT PROPERTY

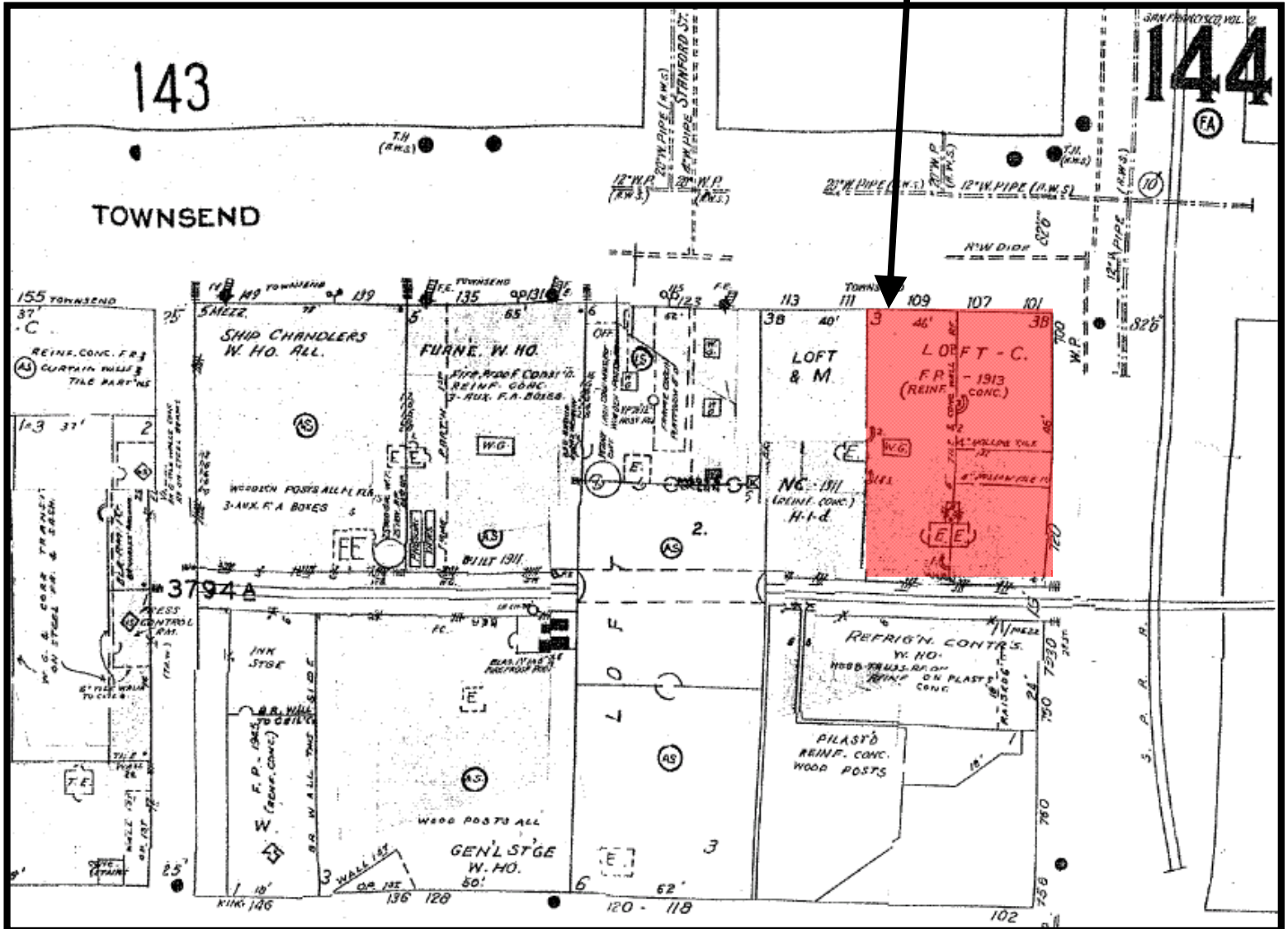

*The Sanborn Maps in San Francisco have not been updated since 1998, and this map may not accurately reflect existing conditions.



Certificate of Appropriateness Hearing
 Case Number 2013.1211A
 101 Townsend Street

Zoning Map

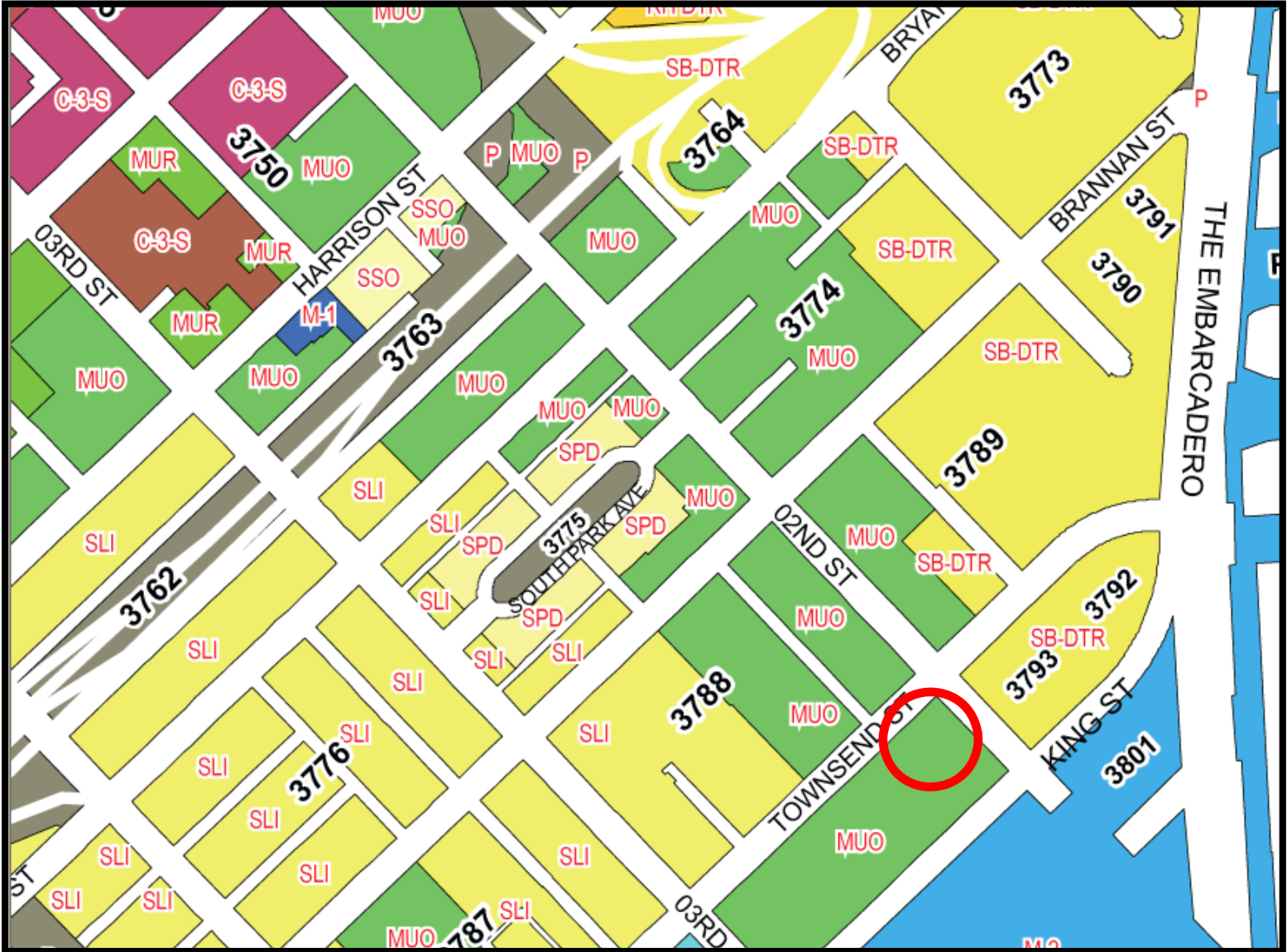

Certificate of Appropriateness Hearing
Case Number 2013.1211A
101 Townsend Street

Aerial Photo



SUBJECT PROPERTY



Certificate of Appropriateness Hearing
Case Number 2013.1211A
101 Townsend Street

Site Photo



101 Townsend Street (Source: SF Planning Dept)

Certificate of Appropriateness Hearing
Case Number 2013.1211A
101 Townsend Street

SITE PLAN

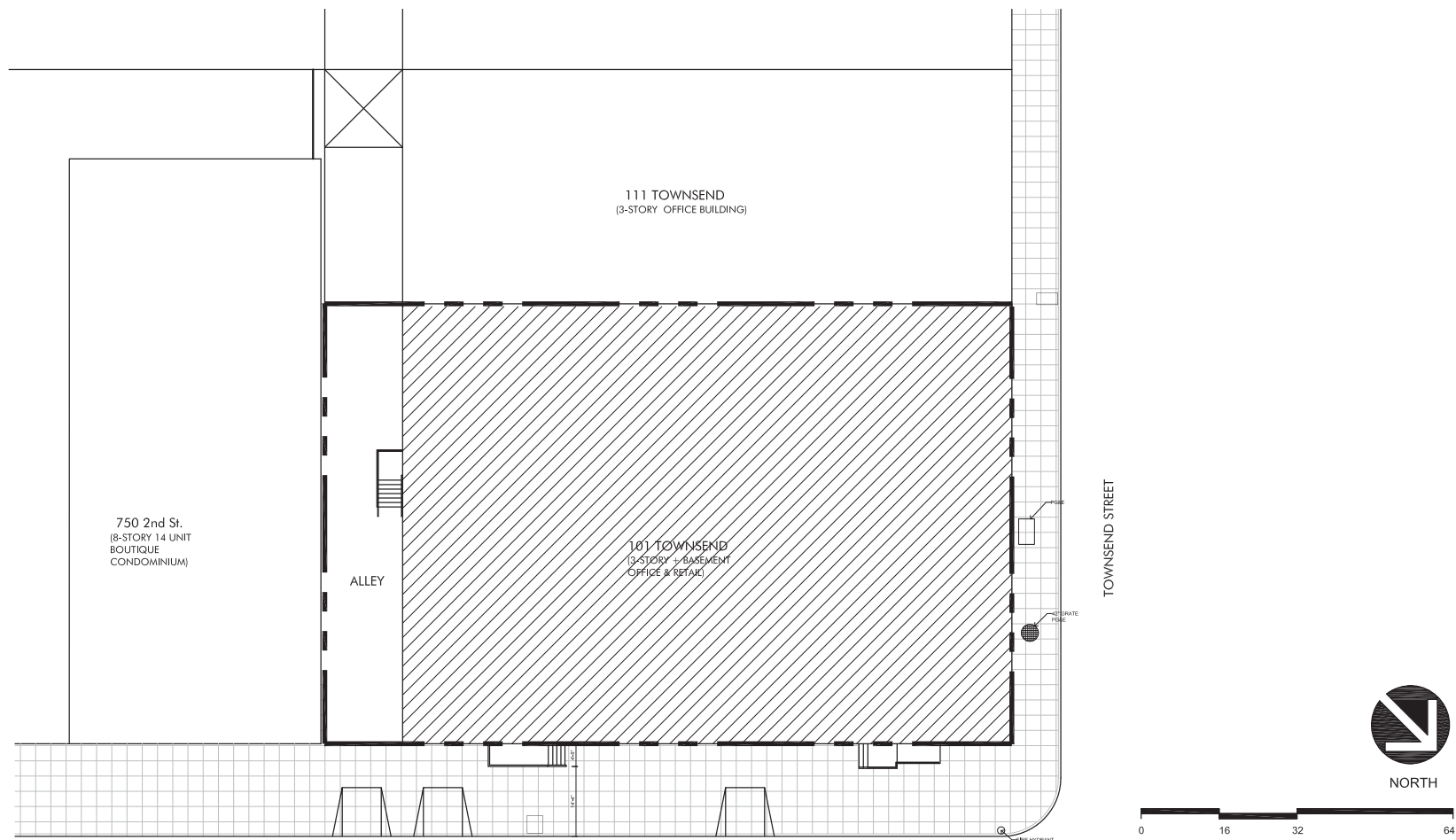

PROJECT DIRECTORY

PROJECT ADDRESS

101 TOWNSEND
SAN FRANCISCO, CA 94107

CLIENT

CIMITAS EQUITY FUND I, LLC
5865 OWENS DRIVE
PLEASANTON, CA 94588
(925) 251-7200
FAX: (925) 251-7201

ARCHITECT

DAHLIN GROUP, INC.
5865 OWENS DRIVE
PLEASANTON, CA 94588
(925) 251-7200
FAX: (925) 251-7201



5865 Owens Drive
Pleasanton, CA 94588
925-251-7200

**101 TOWNSEND
SAN FRANCISCO
CALIFORNIA**

**CERTIFICATE
OF
APPROPRIATENESS
APPLICATION**

REVISED: 02.13.2014

DRAWING INDEX

- A1 TITLE SHEET
- A2 PHOTOS OF THE EXISTING BUILDING
- A2.1 COLOR AND MATERIALS
- A3 EXISTING FLOOR PLANS
- A4 NEW FLOOR PLANS
- A5 ENLARGED FIRST FLOOR PLAN
- A6 ENLARGED ROOF PLAN WITH PENTHOUSE ELEVATIONS
- A7 EXISTING ELEVATIONS
- A7.1 WINDOW ASSESSMENT
- A8 NEW ELEVATIONS
- A9 DIAGRAM OF 150' VIEW STUDY METHOD
- A10 150' VIEW STUDIES

RADIUS MAP - 300'

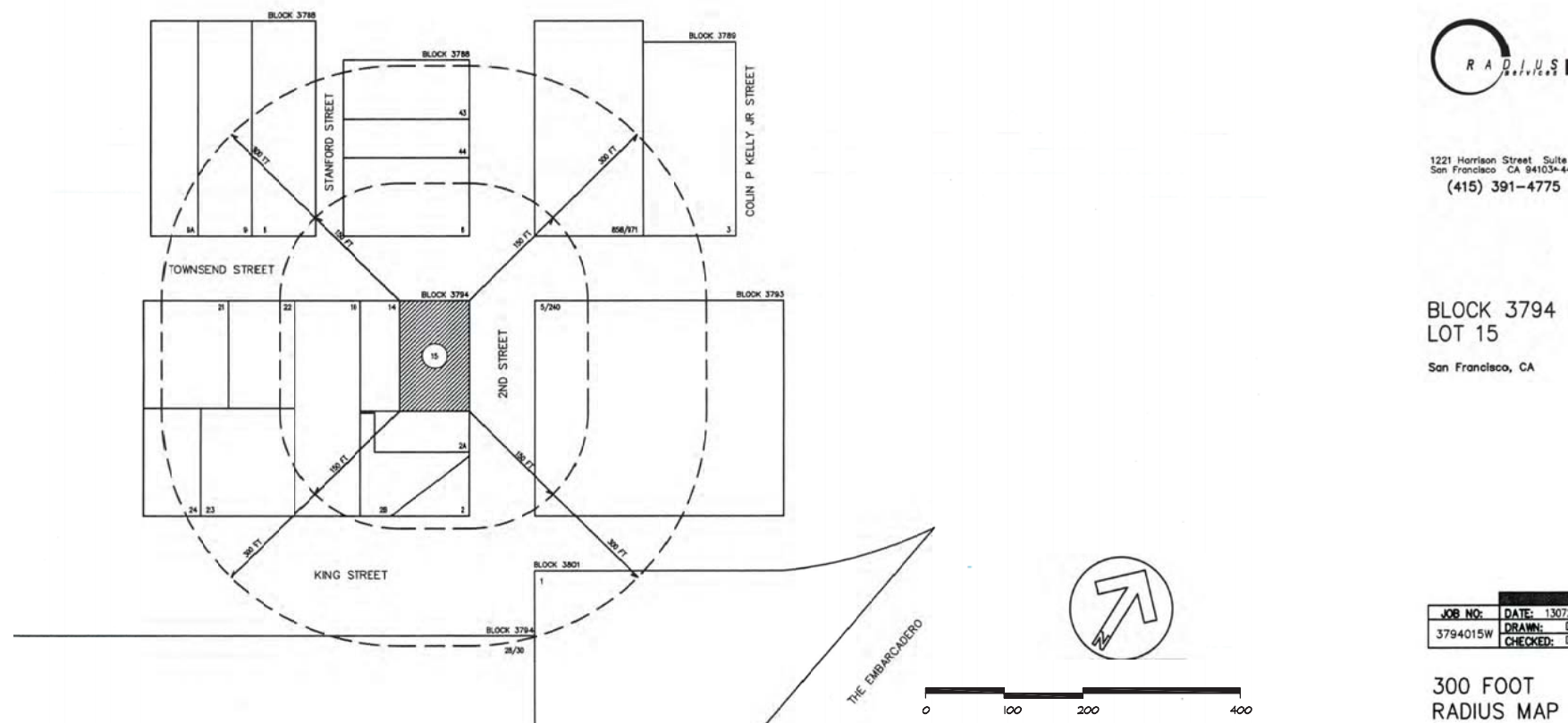

NOTES

REVISIONS

TITLE SHEET

JOB NO. 900.002 SHEET

DRAWN NK

CHECK RV

DATE 08.01.13

A1

101 TOWNSEND
SAN FRANCISCO
CALIFORNIA

**CERTIFICATE
OF
APPROPRIATENESS
APPLICATION**

REVISED: 02.13.2014



4 SOUTH EAST ELEVATION



2 TOWNSEND ELEVATION



3 NORTH EAST CORNER



1 SECOND STREET ELEVATION

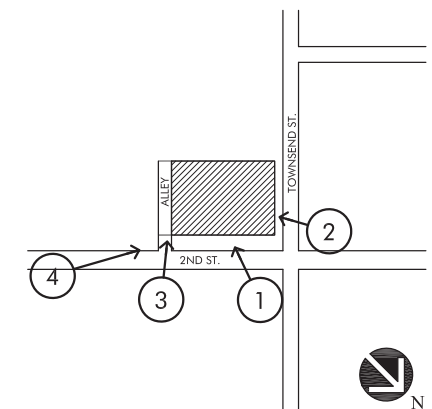

REVISIONS

BUILDING SITE PHOTOS
EXISTING CONDITIONS

JOB NO. 900.002 SHEET
DRAWN NK
CHECK RV
DATE 08.01.13

A2

101 TOWNSEND
SAN FRANCISCO
CALIFORNIA

**CERTIFICATE
OF
APPROPRIATENESS
APPLICATION**

REVISED: 02.13.2014



2

2ND STREET RENDERING VIEW

1

TOWNSEND RENDERING VIEW

FINISH / MATERIALS SCHEDULE

MTL-1	METAL CANOPY: MATERIAL: COLOR:	STEEL B.M. MIDNIGHT OIL 1631
PNT-1	GENERAL PAINT: MANUFACTURER COLOR	BENJAMIN MOORE BRENTWOOD 1223
PNT-2	ACCENT PAINT: MANUFACTURER COLOR	BENJAMIN MOORE WYNWOOD 1231
WNDW-1	WINDOW 1: MANUFACTURER PRODUCT COLOR	CUSTOM WINDOW HISTORICAL SERIES 8300 B.M. MIDNIGHT OIL 1631
WNDW-2	WINDOW 2: PRODUCT COLOR	ALUMINUM STOREFRONT TO MATCH EXISTING
	DESCRIPTION	ALUMINUM STOREFRONT 2 INCH BOX SECTION TO MATCH EXISTING
ROLL DR-1	ROLL UP DOOR PRODUCT COLOR	ROLL UP DOOR TO MATCH EXISTING STOREFRONT
	DESCRIPTION	ROLL UP DOOR, ALUMINUM AND GLASS



ALLEY ELEVATION

5



SECOND STREET ELEVATION

4



TOWNSEND STREET ELEVATION

3

REVISIONS

COLOR AND MATERIALS

JOB NO. 900.002 SHEET
DRAWN NK
CHECK RV
DATE 08.01.13

A2.1

101 TOWNSEND
SAN FRANCISCO
CALIFORNIA

**CERTIFICATE
OF
APPROPRIATENESS
APPLICATION**

REVISED: 02.13.2014

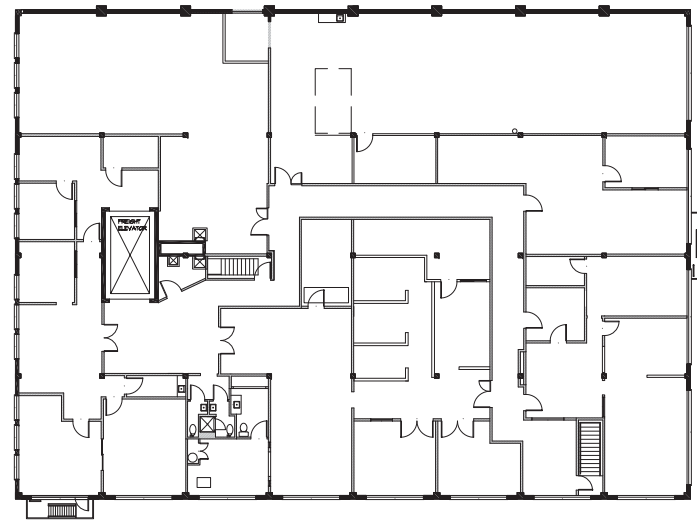

EXISTING 3RD FLOOR PLAN

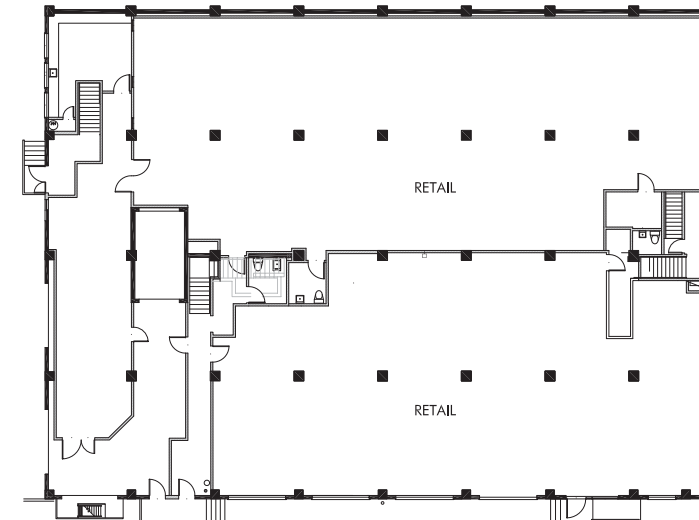

EXISTING 1ST FLOOR PLAN

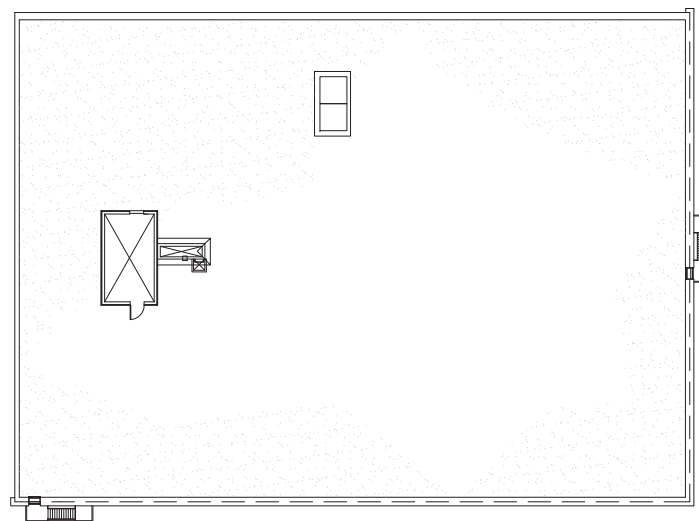

EXISTING ROOF PLAN

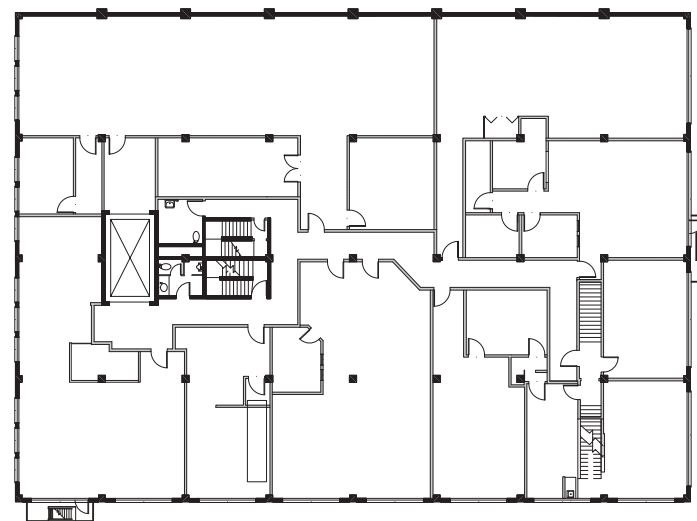

EXISTING 2ND FLOOR PLAN

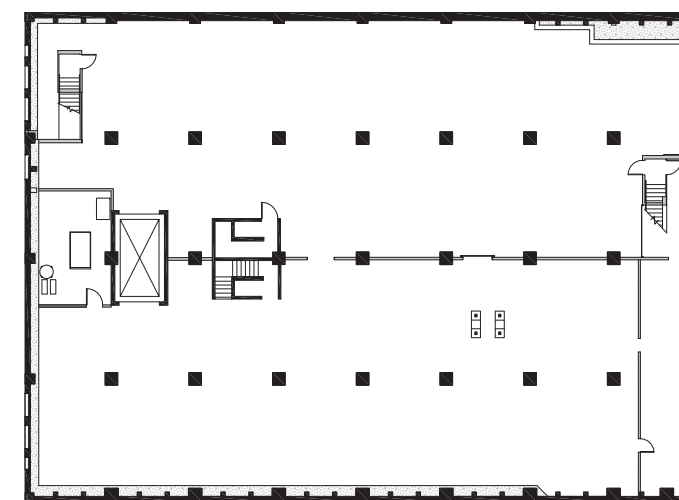

EXISTING BASEMENT PLAN



REVISIONS

EXISTING FLOOR PLANS

JOB NO. 900.002 SHEET

DRAWN Y.Z.

CHECK D.D., K.D.

DATE 08.01.13

A3

101 TOWNSEND
SAN FRANCISCO
CALIFORNIA

**CERTIFICATE
OF
APPROPRIATENESS
APPLICATION**

REVISED: 02.13.2014

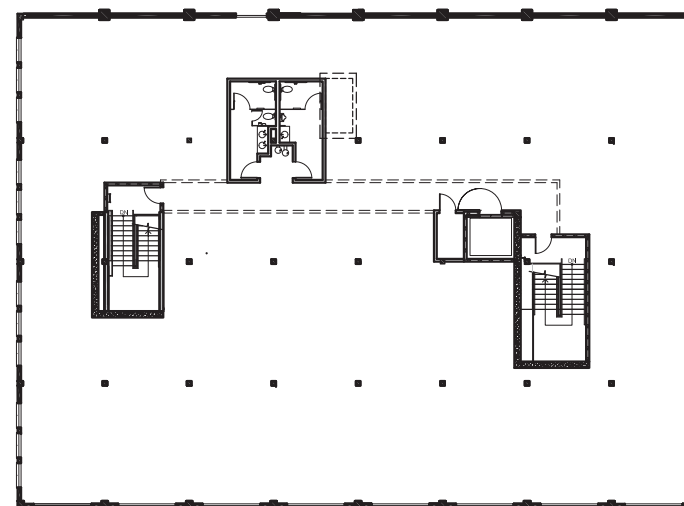

THIRD FLOOR PLAN

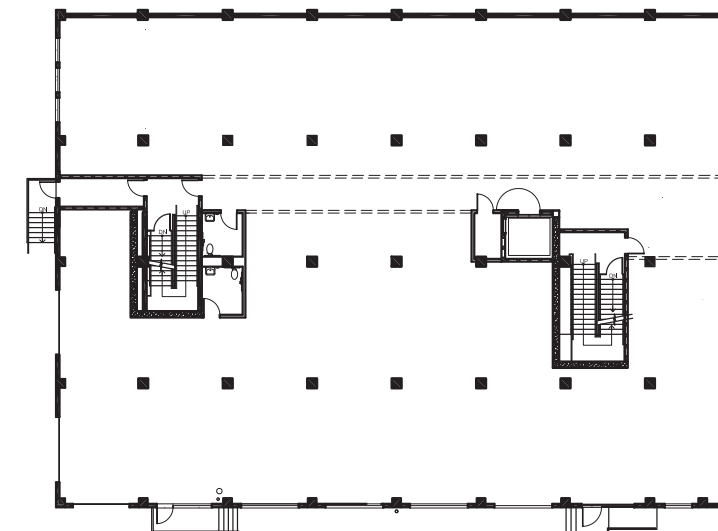

FIRST FLOOR PLAN

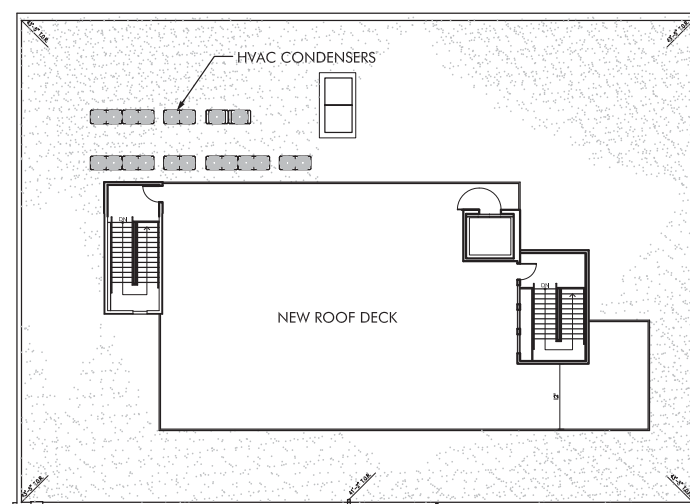

ROOF PLAN

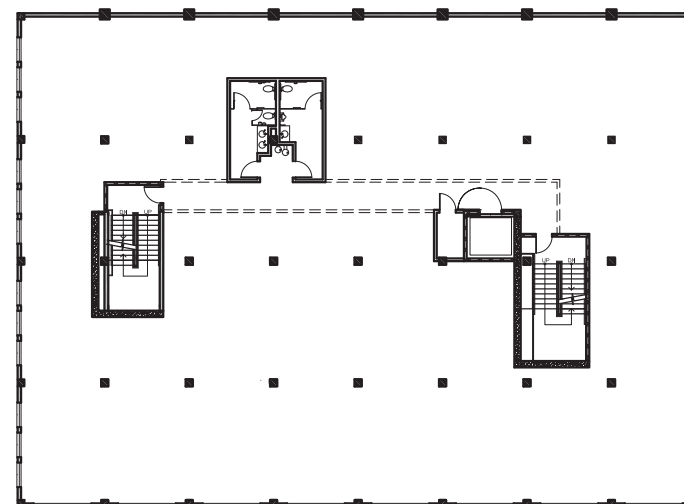

SECOND FLOOR PLAN

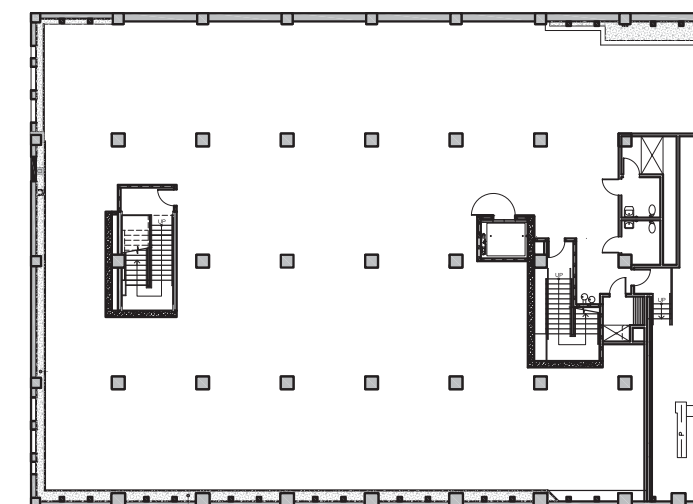

BASEMENT FLOOR PLAN

REVISIONS	

NEW FLOOR PLANS

JOB NO. 900.002 SHEET
DRAWN NK
CHECK RV
DATE 08.01.13

A4



5865 Owens Drive
Pleasanton, CA 94588
925-251-7200

101 TOWNSEND
SAN FRANCISCO
CALIFORNIA

**CERTIFICATE
OF
APPROPRIATENESS
APPLICATION**

REVISED: 02.13.2014

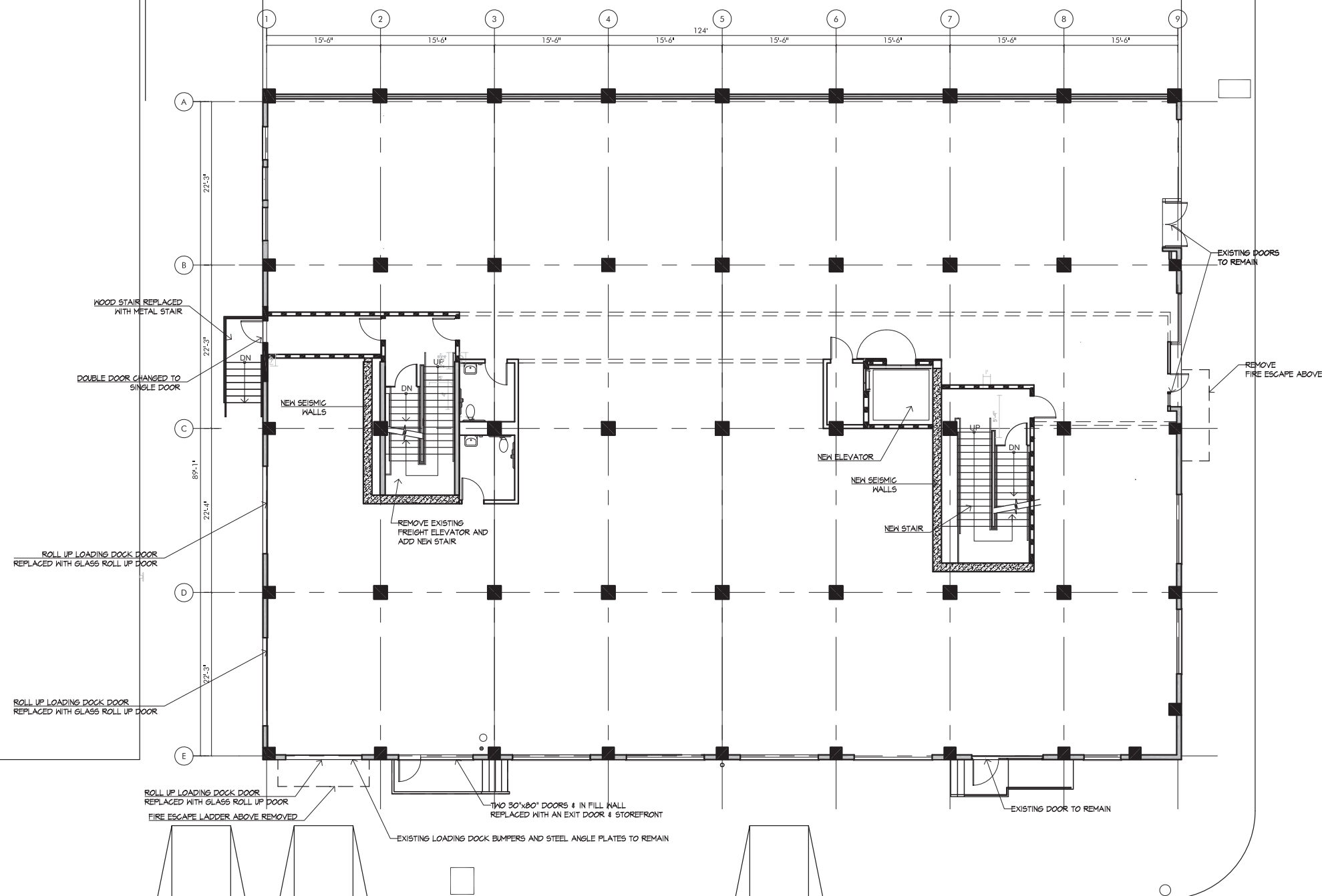

REVISIONS

FIRST FLOOR PLAN

JOB NO. 900.002 SHEET
DRAWN NK
CHECK RV
DATE 08.01.13

A5

101 TOWNSEND
SAN FRANCISCO
CALIFORNIA

**CERTIFICATE
OF
APPROPRIATENESS
APPLICATION**

REVISED: 02.13.2014

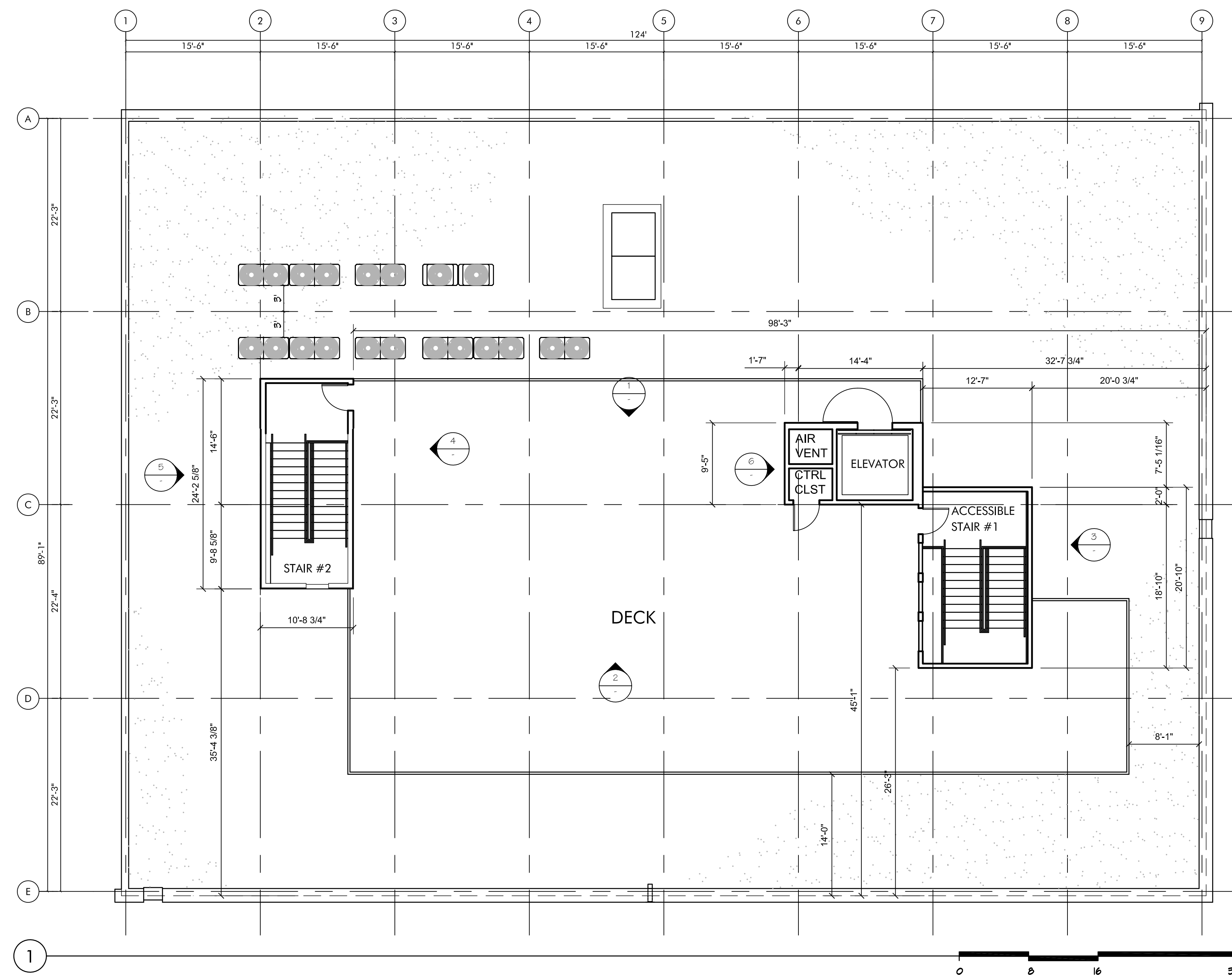
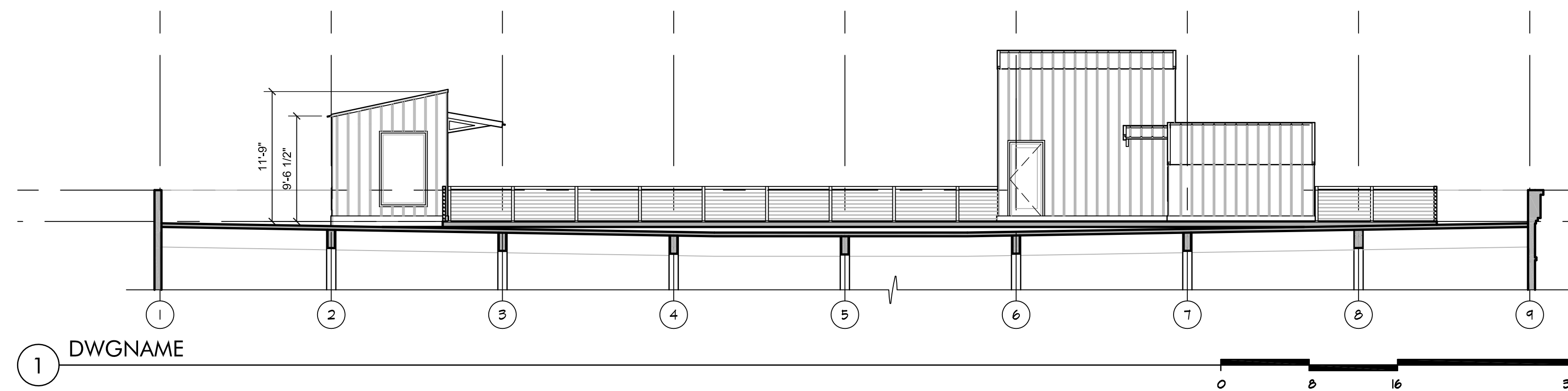
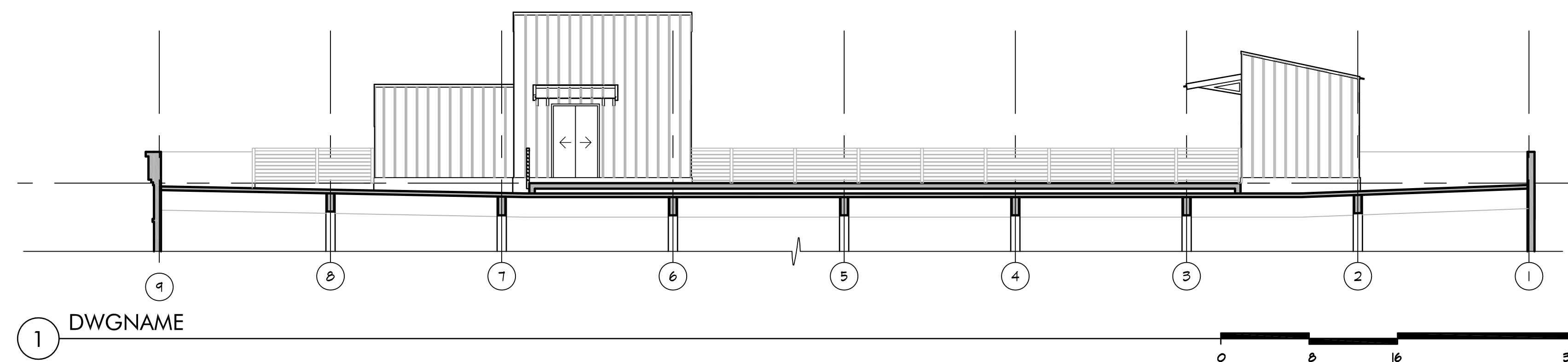
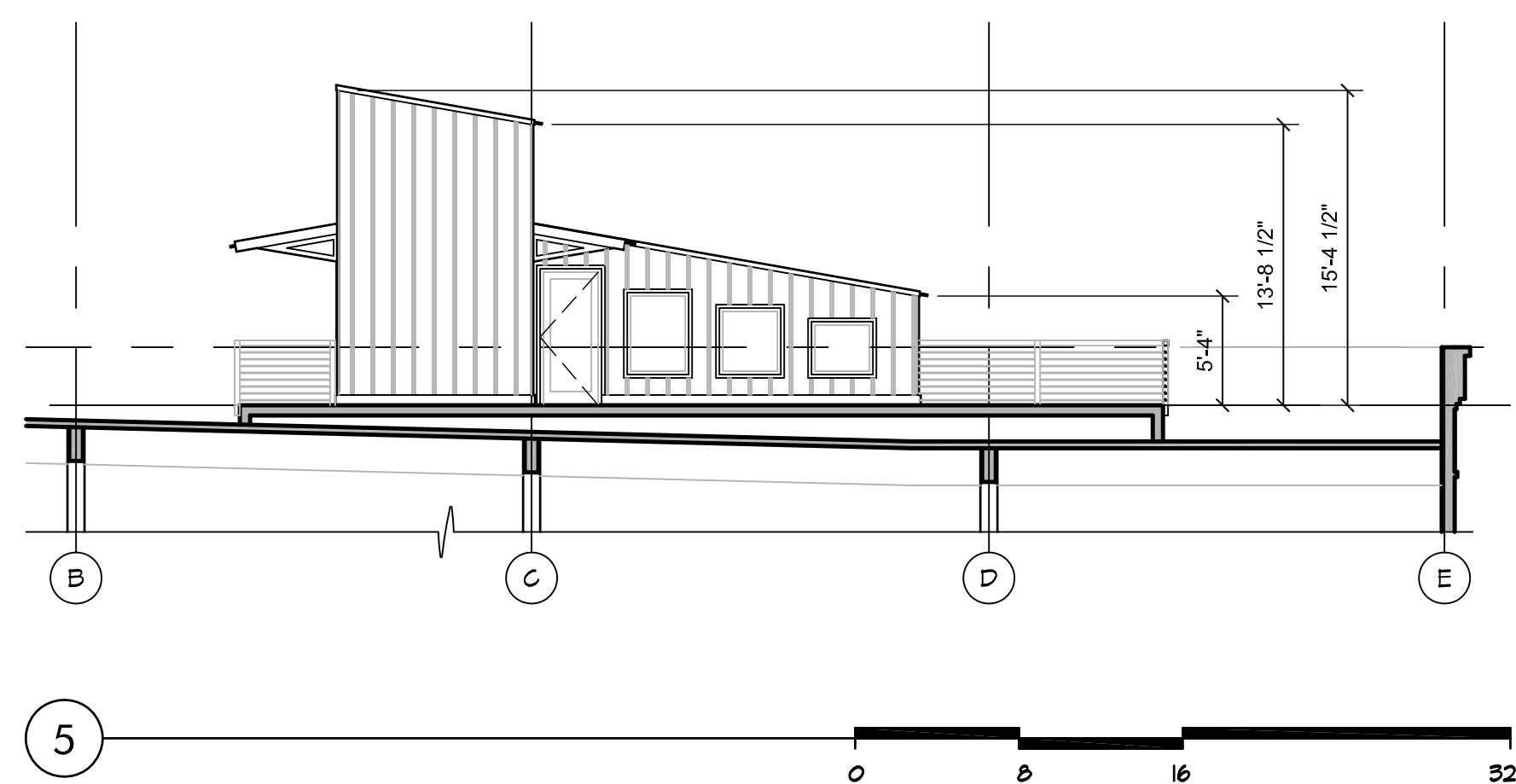
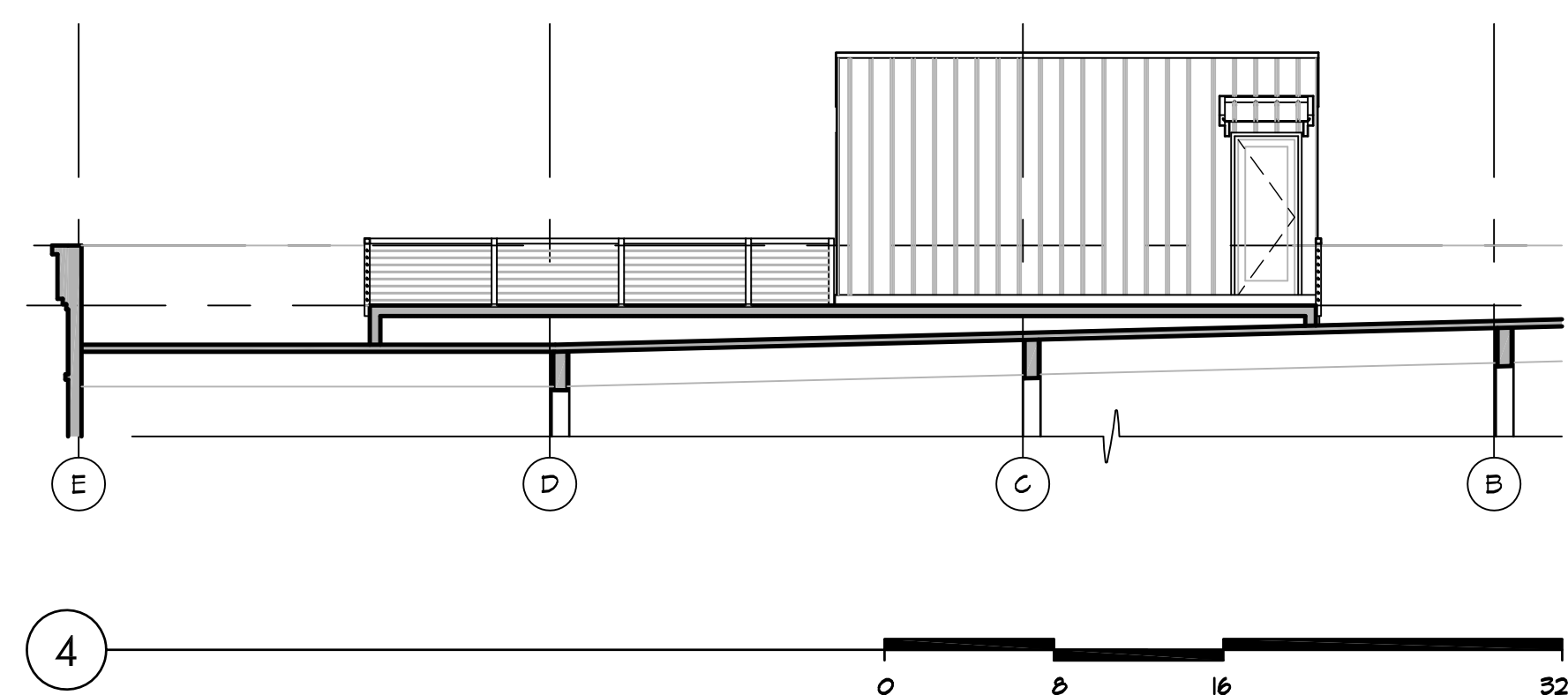
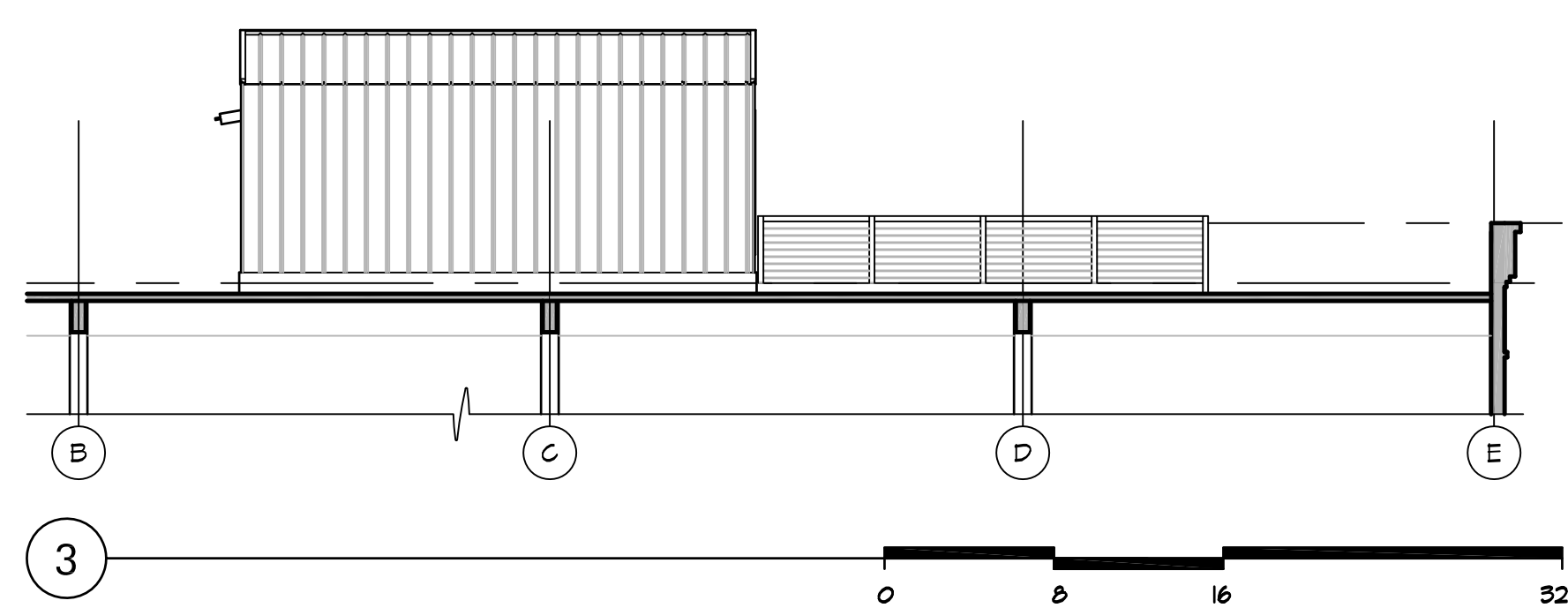
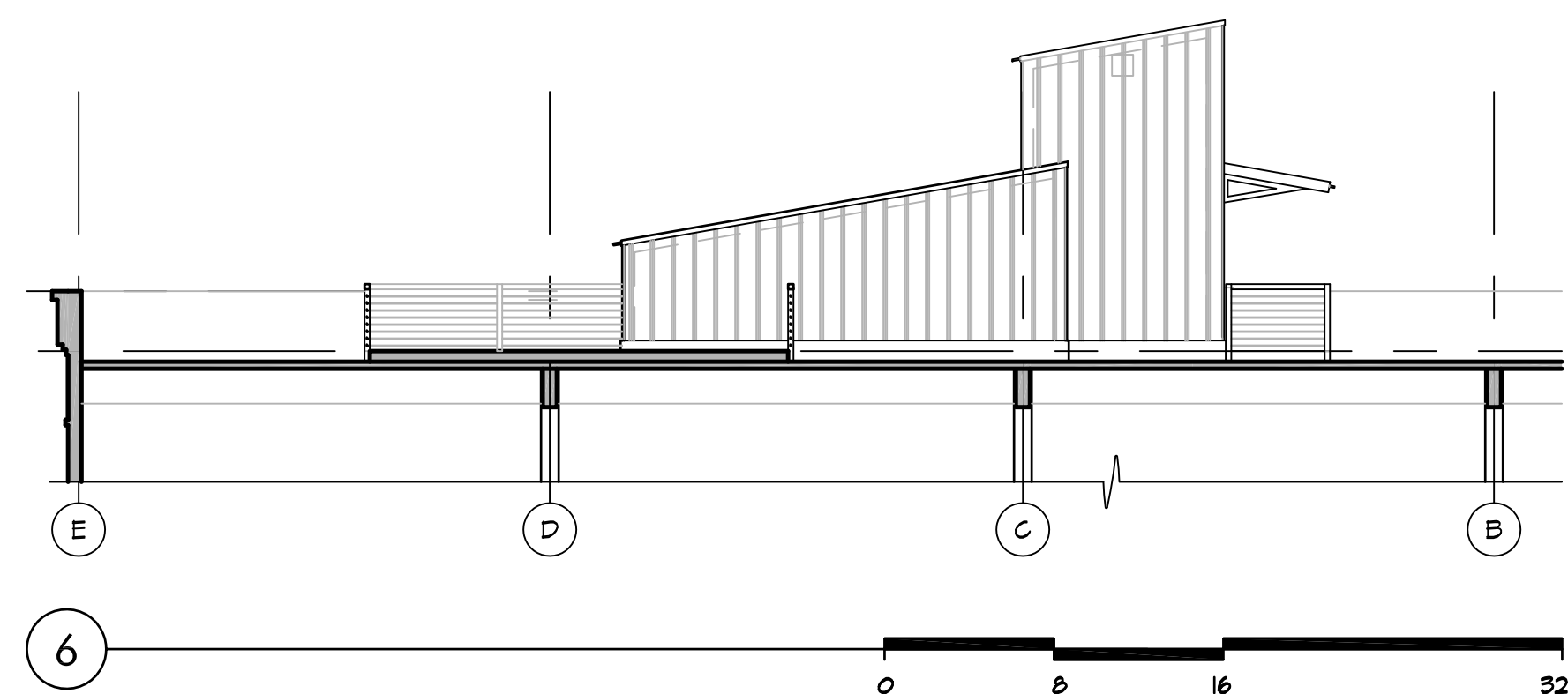

REVISIONS

EXTERIOR UPGRADE_PENTHOUSE

JOB NO. 900.002 SHEET
DRAWN NK
CHECK RV
DATE 08.01.13

A6

**101 TOWNSEND
SAN FRANCISCO
CALIFORNIA**

**CERTIFICATE
OF
APPROPRIATENESS
APPLICATION**

REVISED: 02.13.2014



3 EXISTING ALLEY ELEVATION

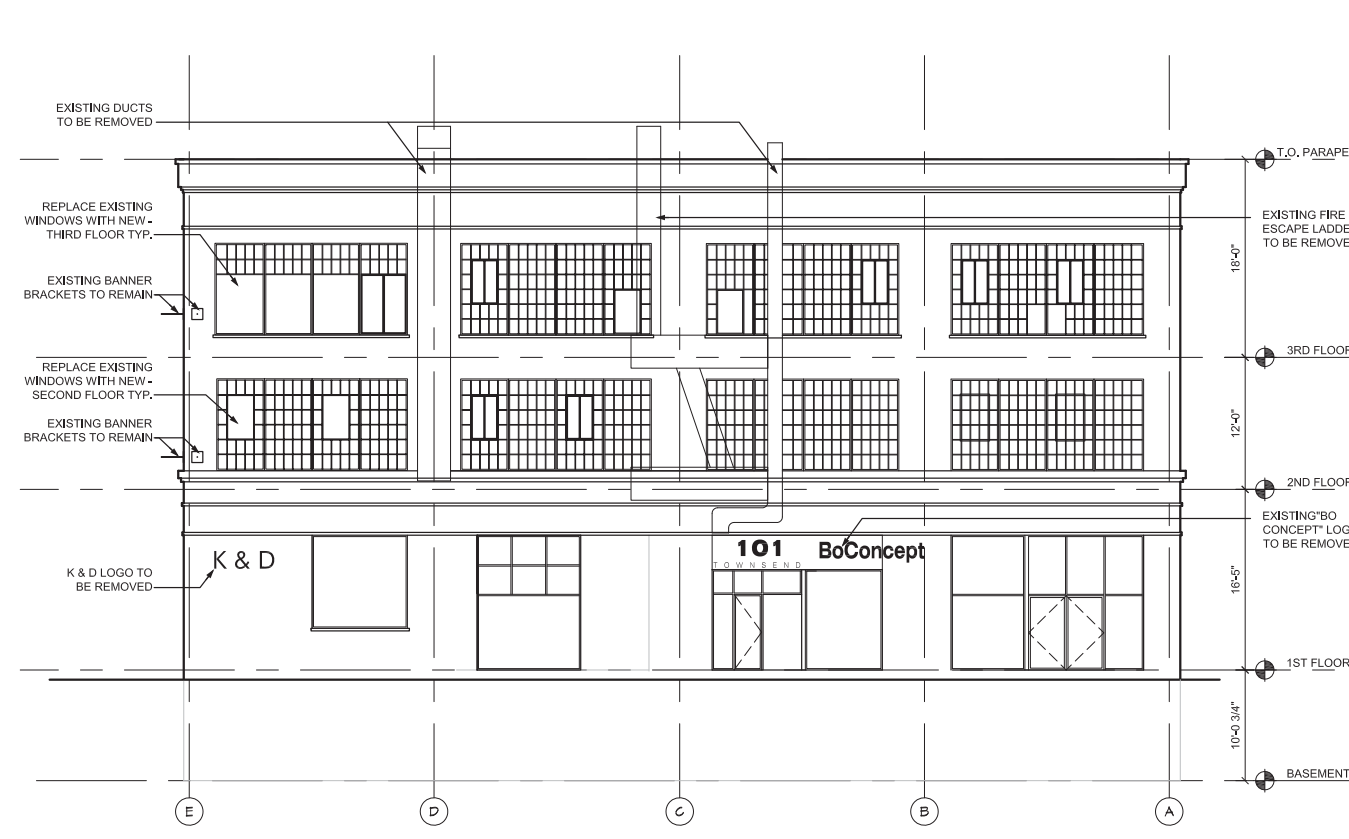

1 EXISTING TOWNSEND STREET ELEVATION

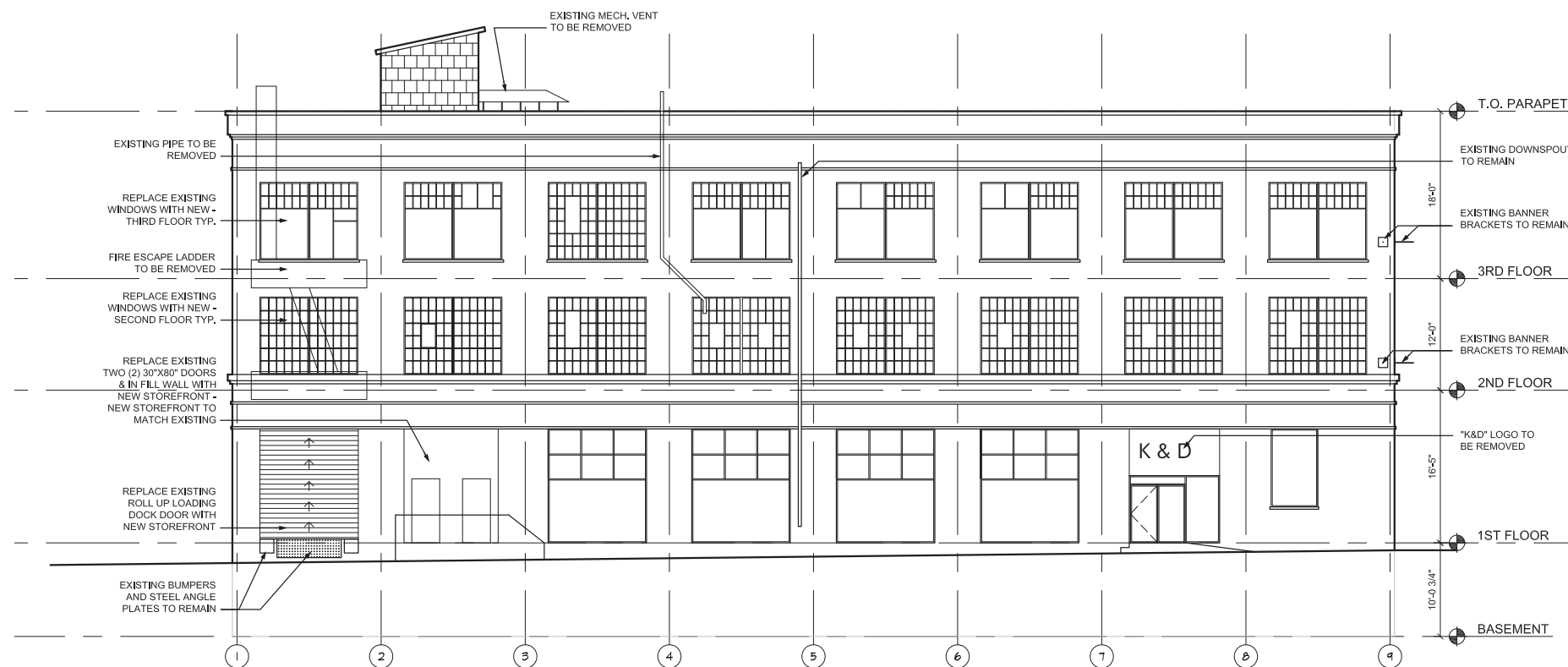

2 EXISTING SECOND STREET ELEVATION

REVISIONS

EXISTING ELEVATIONS

JOB NO. 900.002 SHEET
DRAWN NK
CHECK RV
DATE 08.01.13

A7

101 TOWNSEND
SAN FRANCISCO
CALIFORNIA

**CERTIFICATE
OF
APPROPRIATENESS
APPLICATION**

REVISED: 02.13.2014

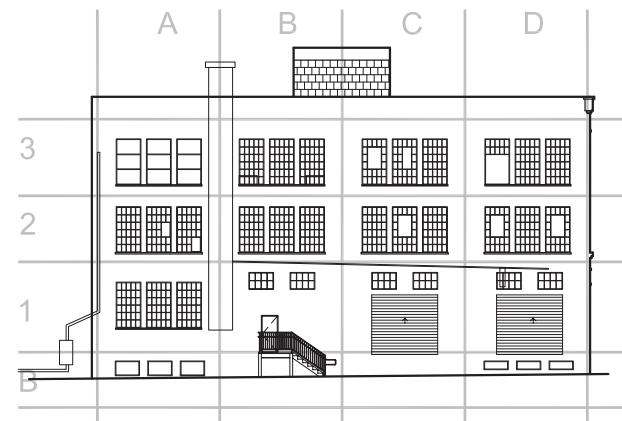

① (E) ALLEY ELEVATION



② (E) SECOND STREET ELEVATION



③ (E) TOWNSEND STREET

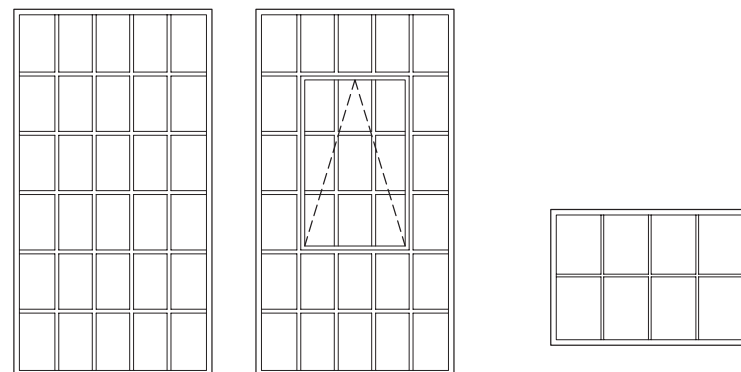

TYPE 1

TYPE 1V

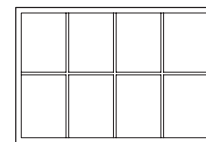

TYPE 4

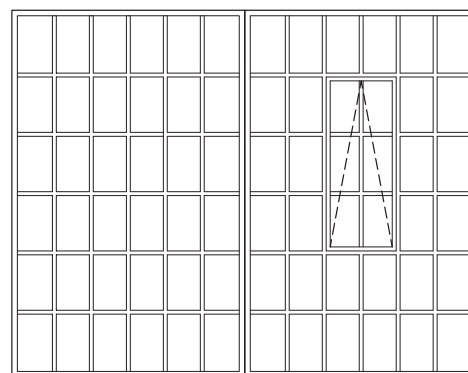

TYPE 2

TYPE 2V

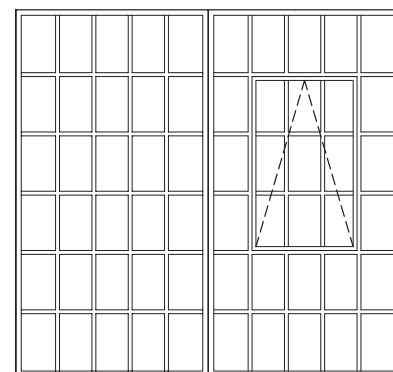

TYPE 3

TYPE 3V

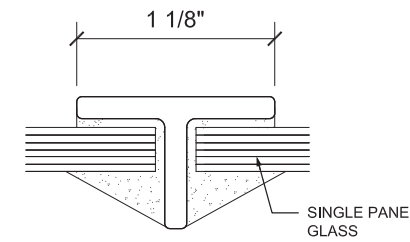

Ⓐ EXISTING MUNTIN

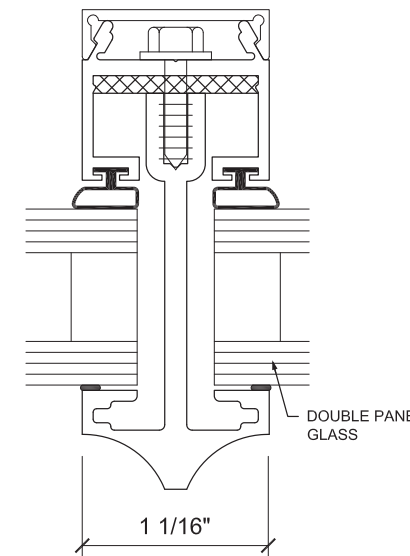

Ⓑ NEW MUNTIN



Ⓒ CUSTOM WINDOW SERIES 8300

Window Assessment Schedule

Grid #	Modified from Original	Frame Type STL = Steel ALM = Aluminum	Remarks	Proposed Action
BA	YES	STL	DUCTS ADDED	replace window with louvered vent
1A	YES	STL, ALM	ALUMINUM VENT AND MECHANICAL ADDED	replace with 8300 Series Historical aluminum window
2A	YES	STL, ALM	SLIDING ALUMINUM VENTS ADDED	replace with 8300 Series Historical aluminum window
3A	YES	ALM	MODERN WINDOWS IN ORIGINAL OPENINGS	replace with 8300 Series Historical aluminum window
BB	YES	STL	LARGE PANES	replace window with louvered vent
1B	YES	STL	DUCTS ADDED	replace with 8300 Series Historical aluminum window
2B	YES	STL, ALM	ALUMINUM SLIDERS AND HOPPERS ADDED	replace with 8300 Series Historical aluminum window
3B	YES	STL, ALM	AC UNITS AND VENTS ADDED	replace with 8300 Series Historical aluminum window
BC	YES	STL	LARGE PANES	replace window with louvered vent
1C	YES	STL	ROLL-UP DOOR, DUCTS ADDED	replace with glass roll-up door
2C	YES	STL, ALM	ALUMINUM HOPPER VENT ADDED	replace with 8300 Series Historical aluminum window
3C	YES	STL, ALM	VENT WINDOW ADDED	replace with 8300 Series Historical aluminum window
BD	YES		INFILLED	no change
1D	YES	STL	DUCTS ADDED	replace with 8300 Series Historical aluminum window
2D	YES	STL, ALM	ALUMINUM HOPPER VENT ADDED	replace with 8300 Series Historical aluminum window
3D	YES	STL, ALM	ENTIRE WINDOW AT CORNER REPLACED WITH ALUMINUM SIDING	replace with 8300 Series Historical aluminum window
1E			ROLL-UP DOOR	replace with glass roll-up door
2E	YES	STL, ALM	ALUMINUM VENT WINDOW ADDED, MULTI-PANE REPLACED WITH LARGE PANE	replace with 8300 Series Historical aluminum window
3E	YES	STL	MULTI-PANE REPLACED WITH LARGE PANES	replace with 8300 Series Historical aluminum window
1F			INFILLED FRAMING WITH E&T DOORS	replace with aluminum storefront to match existing
2F	YES	STL, ALM	ALUMINUM VENT WINDOW ADDED, MULTI-PANE REPLACED WITH LARGE PANE	replace with 8300 Series Historical aluminum window
3F	YES	STL, ALM	MULTI-PANE REPLACE WITH LARGE PANE, ALUMINUM SLIDER ADDED	replace with 8300 Series Historical aluminum window
1G	YES	ALM	ALUMINUM STOREFRONT	no change
2G	YES	STL, ALM	ALUMINUM VENT WINDOW ADDED, MULTI-PANE REPLACED WITH LARGE PANE	replace with 8300 Series Historical aluminum window
3G	NO	STL		replace with 8300 Series Historical aluminum window
1H	YES	ALM	ALUMINUM STOREFRONT	no change
2H	YES	STL, ALM	ALUMINUM HOPPER ADDED, DUCT AND VENTS INFILLED AT TOP SECTION	replace with 8300 Series Historical aluminum window
3H	YES	STL, ALM	MULTI-PANE REPLACED WITH LARGER PANE, ALUMINUM SLIDER ADDED	replace with 8300 Series Historical aluminum window
1I	YES	ALM	ALUMINUM STOREFRONT	no change
2I	YES	STL, ALM	ALUMINUM HOPPER ADDED, DUCT AND VENTS INFILLED AT TOP SECTION	replace with 8300 Series Historical aluminum window
3I	YES	STL, ALM	MULTI-PANE REPLACED WITH LARGER PANE, ALUMINUM SLIDER ADDED	replace with 8300 Series Historical aluminum window
1J	YES	ALM	ALUMINUM STOREFRONT	no change
2J	YES	STL, ALM	ALUMINUM HOPPER ADDED	replace with 8300 Series Historical aluminum window
3J	YES	STL, ALM	MULTI-PANE REPLACED WITH LARGER PANE, ALUMINUM SLIDER ADDED	replace with 8300 Series Historical aluminum window
1K	YES	ALM	ALUMINUM STOREFRONT	no change
2K	YES	STL, ALM	ALUMINUM HOPPER ADDED, MULTI-PANE REPLACED WITH LARGE PANE	replace with 8300 Series Historical aluminum window
3K	YES	STL, ALM	MULTI-PANE REPLACED WITH LARGER PANE, ALUMINUM SLIDER ADDED	replace with 8300 Series Historical aluminum window
1L	YES	ALM	ALUMINUM STOREFRONT	no change
2L	YES	STL, ALM	ALUMINUM HOPPER ADDED	replace with 8300 Series Historical aluminum window
3L	YES	STL, ALM	MULTI-PANE REPLACED WITH LARGER PANE, ALUMINUM SLIDER ADDED	replace with 8300 Series Historical aluminum window
1M	YES	ALM	ALUMINUM STOREFRONT	no change
2M	YES	STL, ALM	ALUMINUM HOPPER ADDED	replace with 8300 Series Historical aluminum window
3M	YES	STL, ALM	MULTI-PANE REPLACED WITH LARGER PANE, ALUMINUM SLIDER ADDED	replace with 8300 Series Historical aluminum window
1N	YES	ALM	ALUMINUM STOREFRONT	no change
2N	YES	STL, ALM	ALUMINUM HOPPER ADDED	replace with 8300 Series Historical aluminum window
3N	YES	STL, ALM	MULTI-PANE REPLACED WITH LARGER PANE, ALUMINUM SLIDER ADDED	replace with 8300 Series Historical aluminum window
1O	YES	ALM	ALUMINUM STOREFRONT	no change
2O	NO	STL		replace with 8300 Series Historical aluminum window
3O	YES	STL, ALM	MULTI-PANE REPLACED WITH LARGER PANE, ALUMINUM SLIDER ADDED	replace with 8300 Series Historical aluminum window
1P	YES	ALM	ALUMINUM STOREFRONT	no change
2P	YES	STL, ALM	ALUMINUM HOPPER ADDED	replace with 8300 Series Historical aluminum window
3P	YES	STL, ALM	MULTI-PANE REPLACED WITH LARGER PANE, ALUMINUM SLIDER ADDED	replace with 8300 Series Historical aluminum window

REVISIONS

WINDOW ASSESSMENT

JOB NO. 900.002 SHEET

DRAWN NK

CHECK RV

DATE 08.01.13

A7.1

101 TOWNSEND
SAN FRANCISCO
CALIFORNIA

**CERTIFICATE
OF
APPROPRIATENESS
APPLICATION**

REVISED: 02.13.2014

GENERAL NOTES

1. EXISTING STEEL WINDOWS TO BE REPLACED WITH CUSTOM WINDOW 8300 HISTORICAL SERIES WITH TRUE DIVIDED LITES AND PANE SIZE TO MATCH ORIGINAL.
2. ALUMINUM STOREFRONT TO MATCH EXISTING
3. NEW LOUVERS
4. ROLL UP GLASS DOOR

WINDOWS TO BE REMOVED OR ADDED

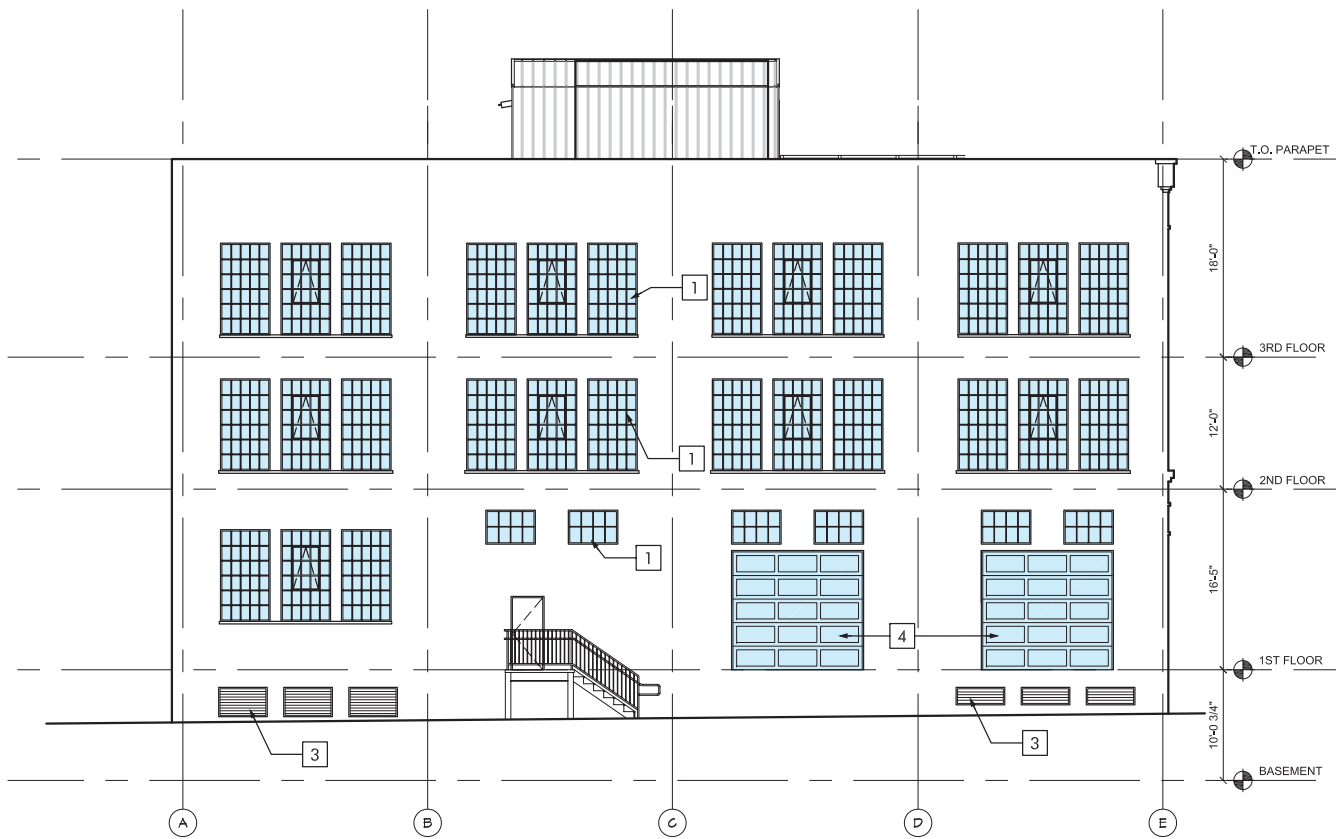

1 NEW ALLEY ELEVATION



3 NEW TOWNSEND STREET ELEVATION

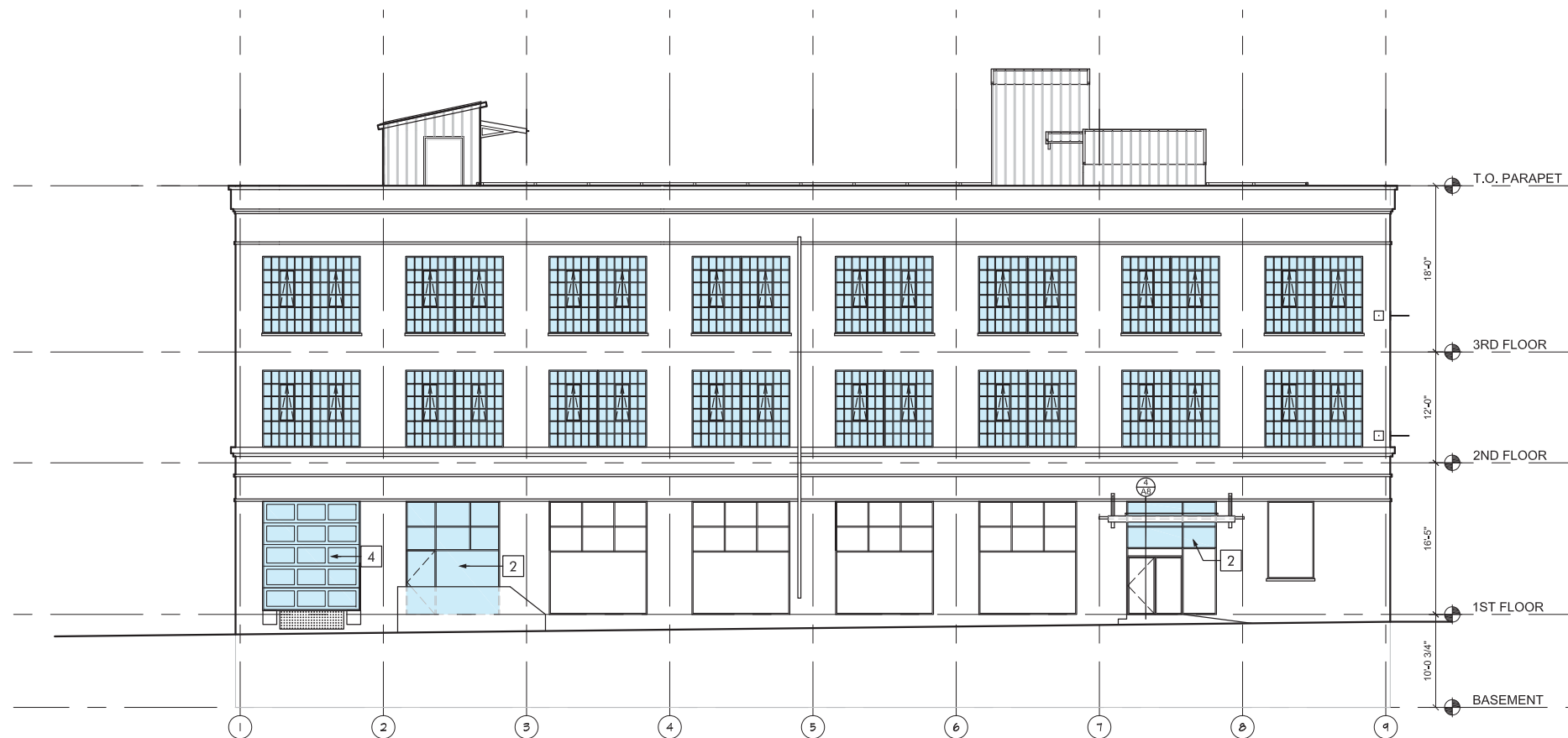

2 NEW SECOND STREET ELEVATION

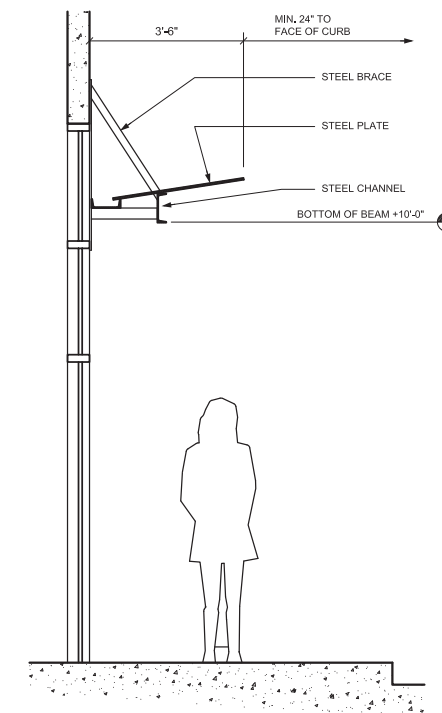

4 CANOPY AT ENTRY
SCALE 1" = 1'-0"

REVISIONS	

NEW ELEVATIONS

JOB NO. 900.002 SHEET
DRAWN NK
CHECK RV
DATE 08.01.13

A8

101 TOWNSEND
SAN FRANCISCO
CALIFORNIA

**CERTIFICATE
OF
APPROPRIATENESS
APPLICATION**

REVISED: 02.13.2014

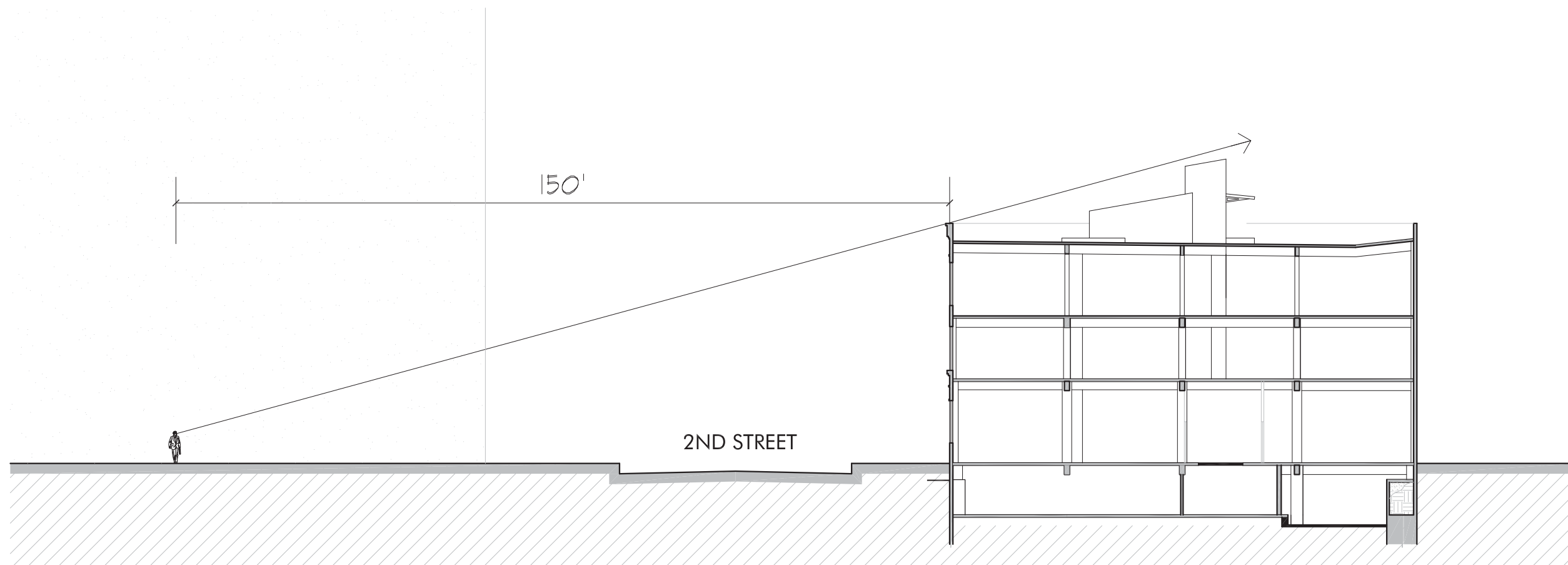

① VIEW ALONG TOWNSEND STREET

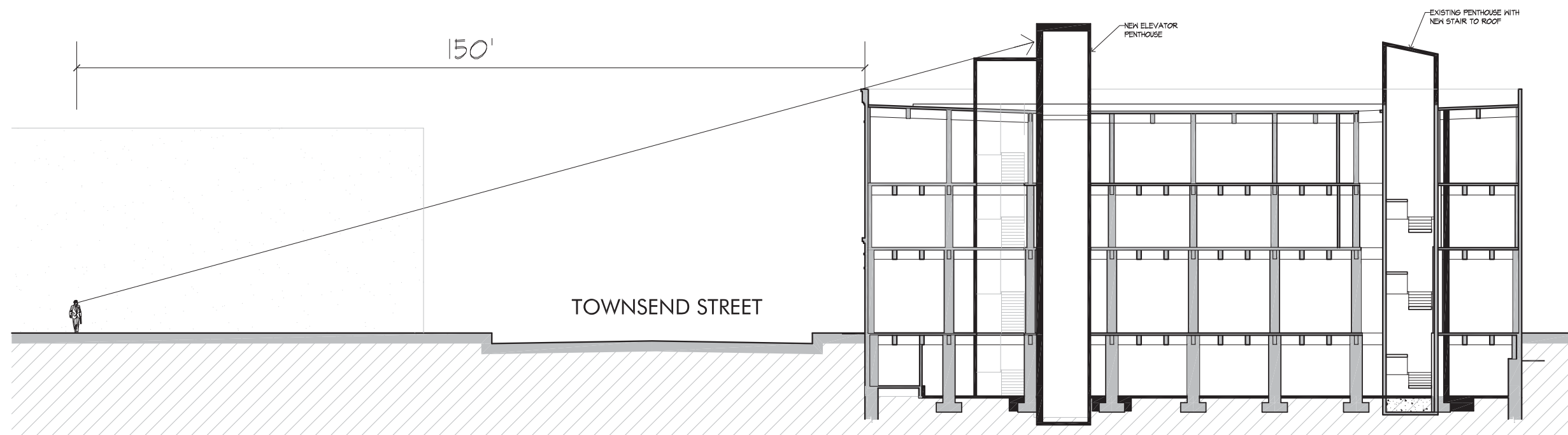

② VIEW ALONG 2ND STREET



REVISIONS

NO.	DESCRIPTION

DIAGRAM OF VIEW STUDY METHOD

JOB NO. 900.002 SHEET
DRAWN NK
CHECK RV
DATE 08.01.13

A9

101 TOWNSEND
SAN FRANCISCO
CALIFORNIA

**CERTIFICATE
OF
APPROPRIATENESS
APPLICATION**

REVISED: 02.13.2014

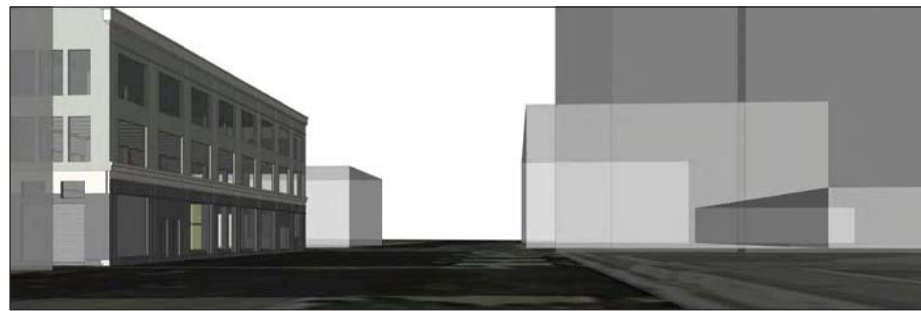

(A) VIEW FROM SE 2ND STREET_EXISTING

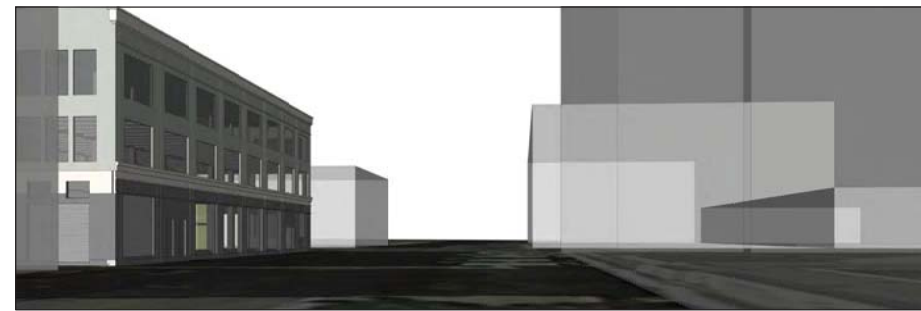

(A) VIEW FROM SE 2ND STREET_NEW



(A) BIRDS EYE VIEW_NEW



(B) VIEW FROM NW 2ND STREET_EXISTING



(B) VIEW FROM NW 2ND STREET_NEW

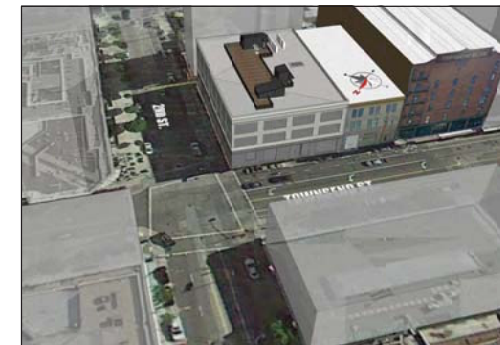

(B) BIRDS EYE VIEW_NEW



(C) VIEW FROM NE TOWNSEND STREET_EXISTING



(C) VIEW FROM NE TOWNSEND STREET_NEW

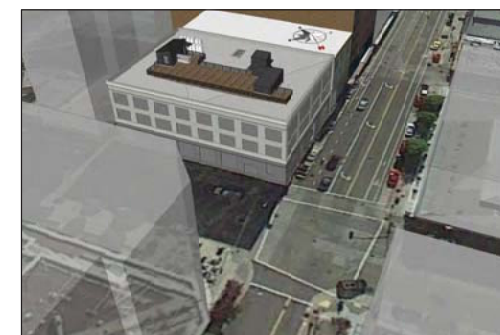

(C) BIRDS EYE VIEW_NEW

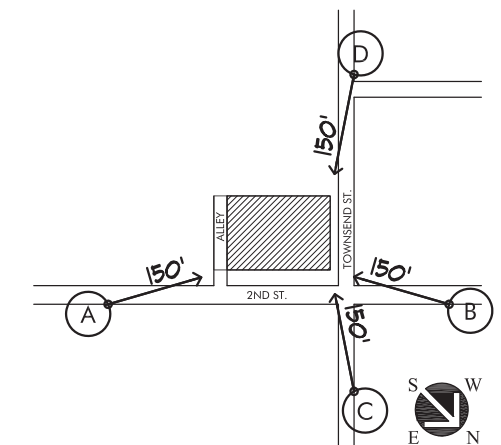

(D) VIEW FROM SW TOWNSEND STREET_EXISTING

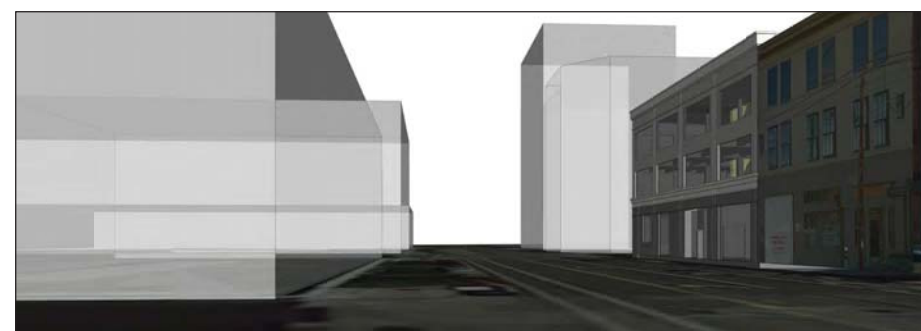

(D) VIEW FROM SW TOWNSEND STREET_NEW

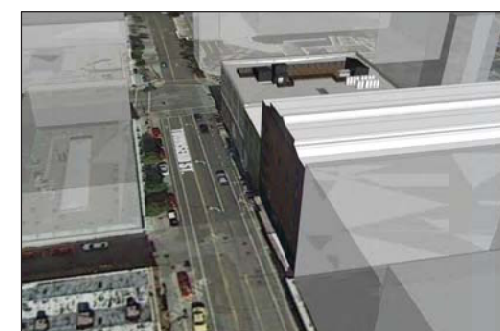

(D) BIRDS EYE VIEW_NEW

REVISIONS	

150' RADIUS VIEW STUDIES

JOB NO. 900.002 SHEET
DRAWN NK
CHECK RV
DATE 08.01.13 **A10**



5865 Owens Drive
Pleasanton, CA 94588
925-251-7200

101 TOWNSEND
SAN FRANCISCO
CALIFORNIA

**CERTIFICATE
OF
APPROPRIATENESS
APPLICATION**

REVISED: 03.11.2014



4

SECOND STREET ELEVATION

COLOR AND MATERIALS
CERTIFICATE OF APPROPRIATENESS APPLICATION

REF. SHEET: 4/A2.1

JOB NO. 900.002
DATE 03-11-2014

ASK-01

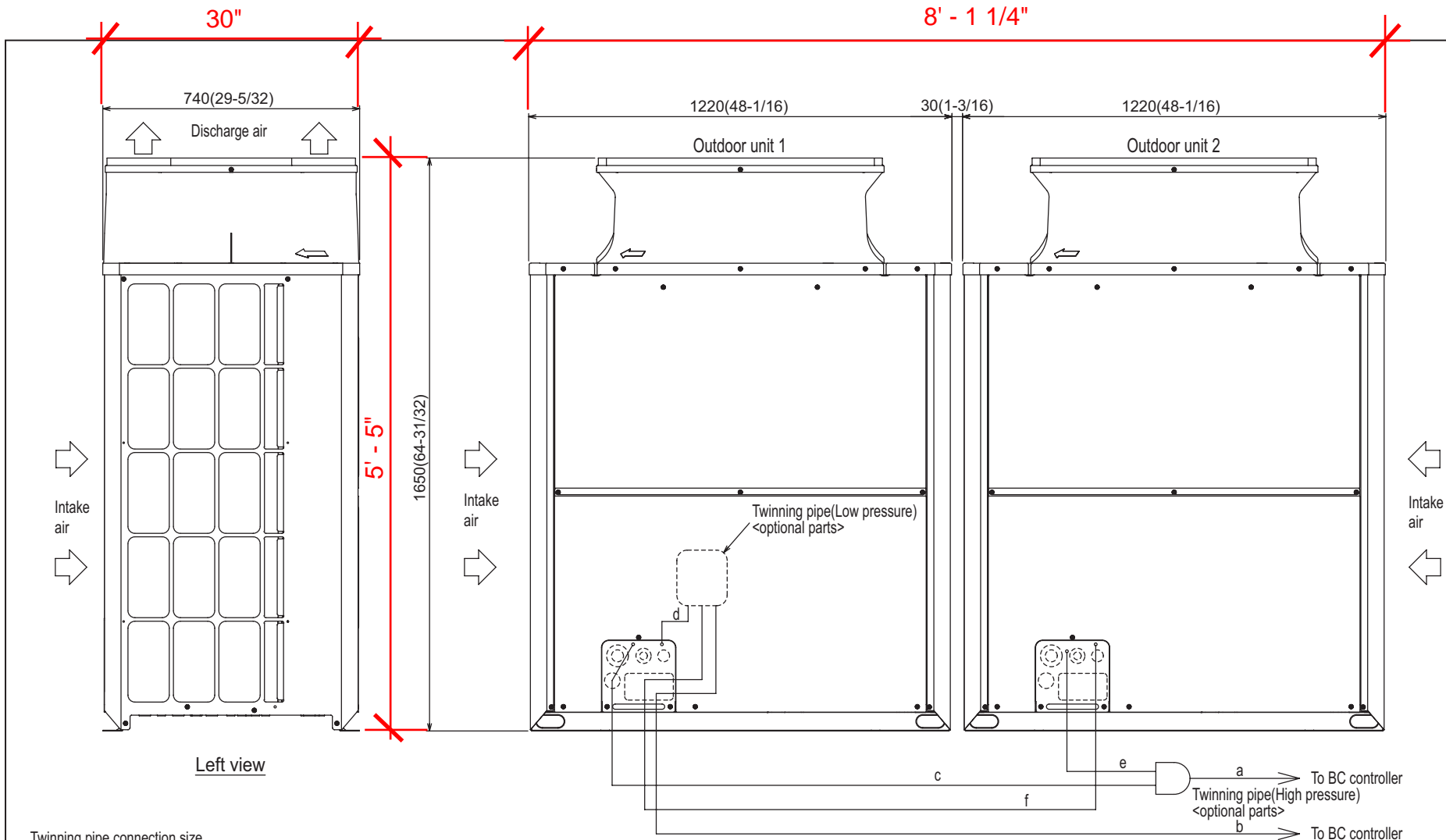

Left view

Front view

Twinning pipe connection size

Package unit name		PURY-P168TSKMU-A(-BS)	PURY-P192TSKMU-A(-BS)
Component unit name	Outdoor unit 1	PURY-P96TKMU-A(-BS)	PURY-P96TKMU-A(-BS)
	Outdoor unit 2	PURY-P72TKMU-A(-BS)	PURY-P96TKMU-A(-BS)
Outdoor Twinning Kit(optional parts)		CMY-R100CBK2	
BC controller~Twinning pipe	High pressure	a	ø22.2(7/8)
	Low pressure	b	ø28.58(1-1/8)

	Unit model	P168		P192	
	Component unit model	P96	P72	P96	P96
Twinning Kit ~Outdoor unit	High pressure	c ø19.05(3/4)	e ø15.88(5/8)	c ø19.05(3/4)	e ø19.05(3/4)
	Low pressure	d - (Note 5)	f ø19.05(3/4)	d - (Note 5)	f ø22.2(7/8)

- Note 1. Connect the pipes as shown in the figure above. Refer to the table above for the pipe size.
 2. Twinning pipe (High pressure) should not be tilted more than 15 degrees from the horizontal plane.
 Be sure to see the Installation Manual for details of Twinning pipe installation.
 3. The pipe section before the Twinning pipe (section "a" in the figure) must have at least 500mm(19-11/16) of straight section
 (*including the straight pipe that is supplied with the Twinning pipe).
 4. Only use the Twinning pipe by Mitsubishi (optional parts).
 5. Connect the outdoor unit 1 with the Twinning pipe (Low pressure) (section "d" in the figure).

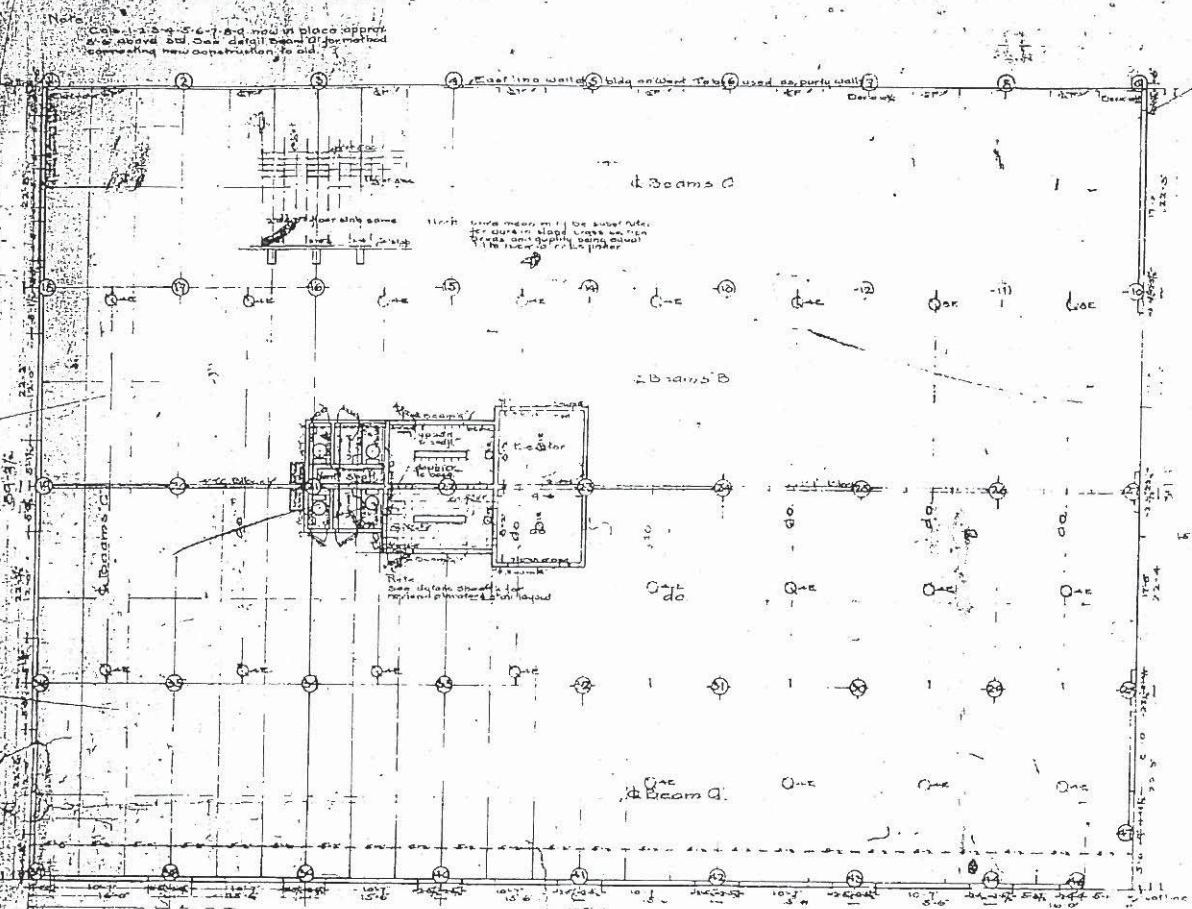

First Floor Plan
Second Street

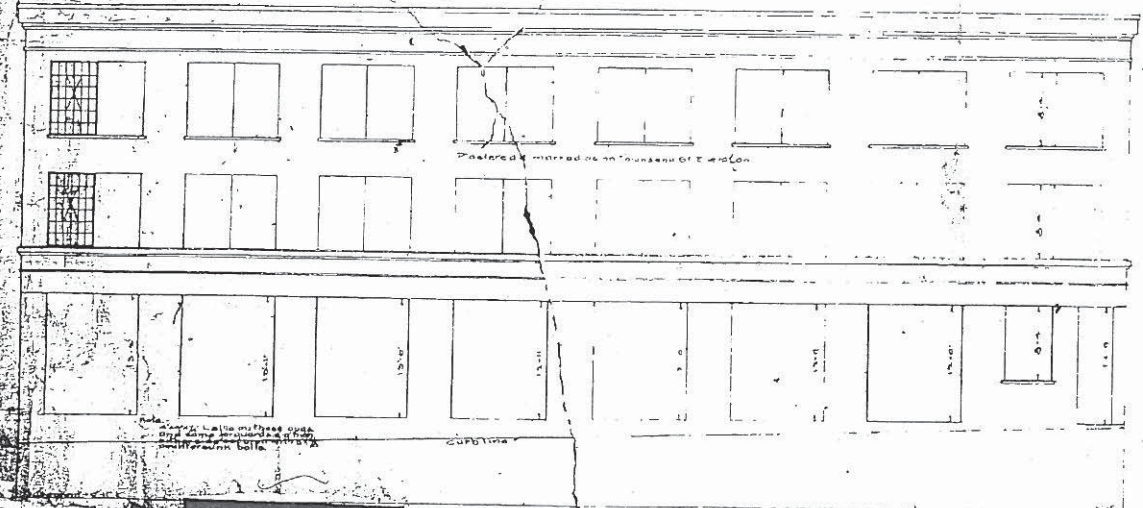

Second Street Elevation

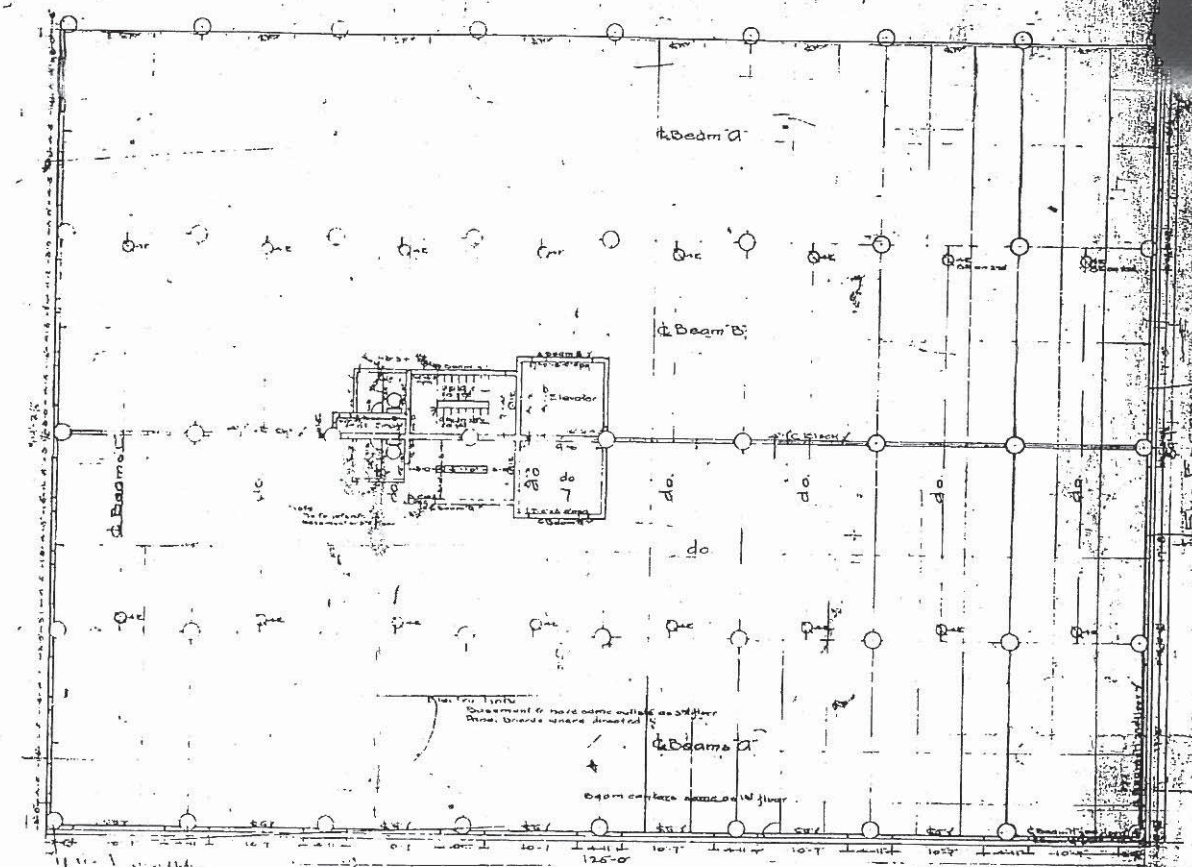

2nd Floor Plan

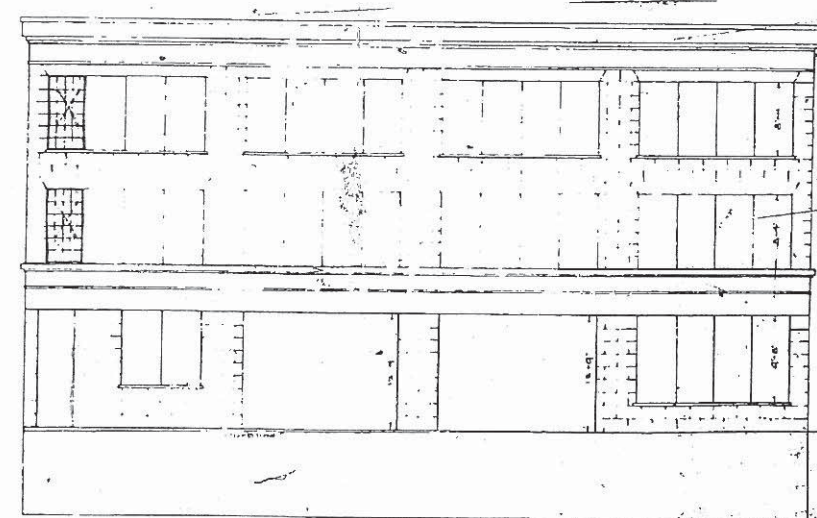

Townsend Street Elevation

BUILDING FOR
THE WAREHOUSE INVESTMENT
 3.4 CORNER TOWNSEND ST
 SAN FRANCISCO, CALIF.
 GEORGE HORNLEIN & CO. ARCHITECTS
 PACIFIC BLDG.

146973

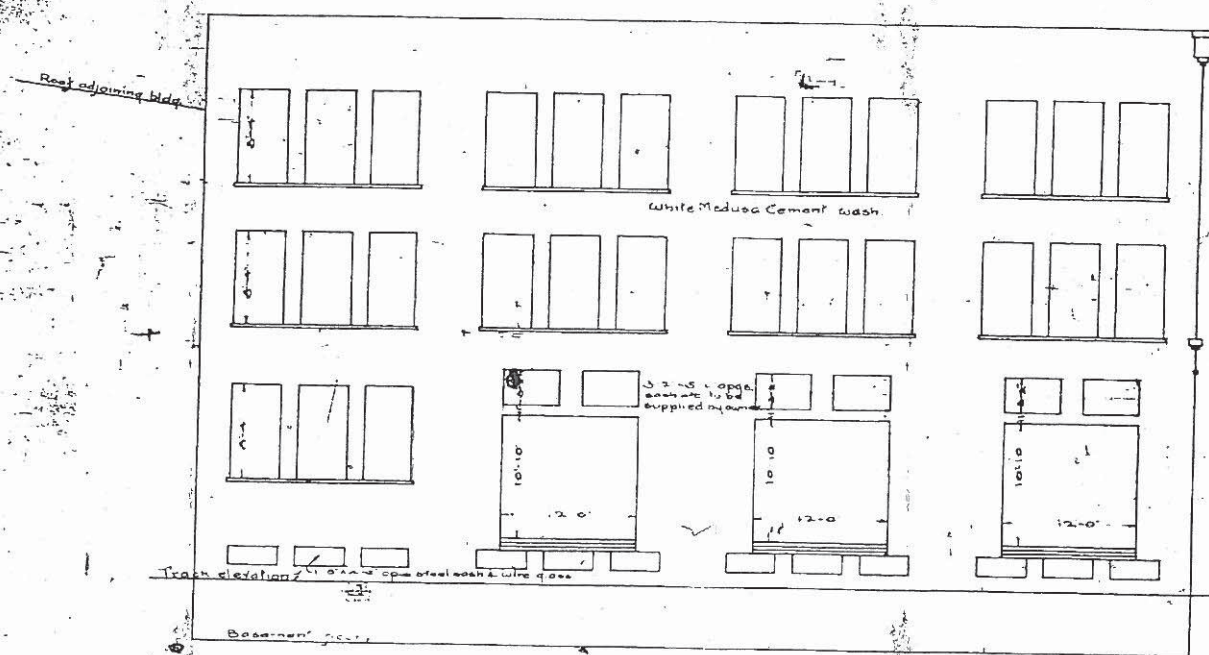

Rear Elevation

BUILDING FOR
THE WAREHOUSE INVESTMENT CO.
 341 COR. 2ND & TOWNSEND STS.
 SAN FRANCISCO - CALIF.
A.E. HORNLEIN - C.E.
 PACIFIC BLDG.

Scale 1/4" = 1'-0"
 1/2" = 1'-0"





EXISTING ELEVATIONS
101 TOWNSEND, SAN FRANCISCO



JOB NO. 900.002
DATE 03-12-2014

W.1



EXISTING ELEVATIONS
101 TOWNSEND, SAN FRANCISCO



JOB NO. 900.002
DATE 03-12-2014

W.2



EXISTING ELEVATIONS
101 TOWNSEND, SAN FRANCISCO



JOB NO. 900.002
DATE 03-12-2014

W.3



EXISTING ELEVATIONS
101 TOWNSEND, SAN FRANCISCO



JOB NO. 900.002
DATE 03-12-2014

W.4



EXISTING ELEVATIONS
101 TOWNSEND, SAN FRANCISCO



JOB NO. 900.002
DATE 03-12-2014

W.5

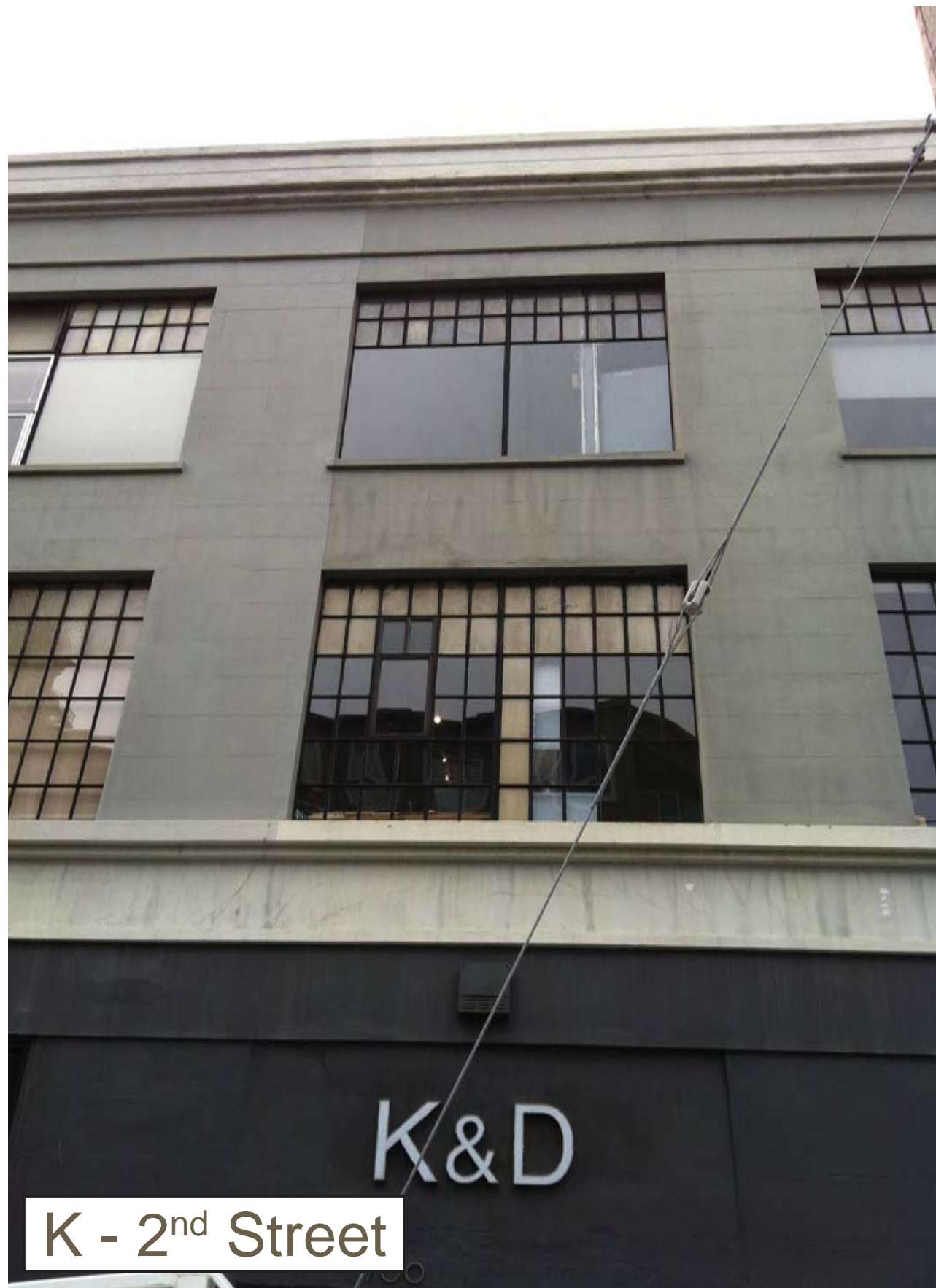

K - 2nd Street



L - 2nd Street

EXISTING ELEVATIONS
101 TOWNSEND, SAN FRANCISCO



JOB NO. 900.002
DATE 03-12-2014

W.6



EXISTING ELEVATIONS
101 TOWNSEND, SAN FRANCISCO



JOB NO. 900.002
DATE 03-12-2014

W.7

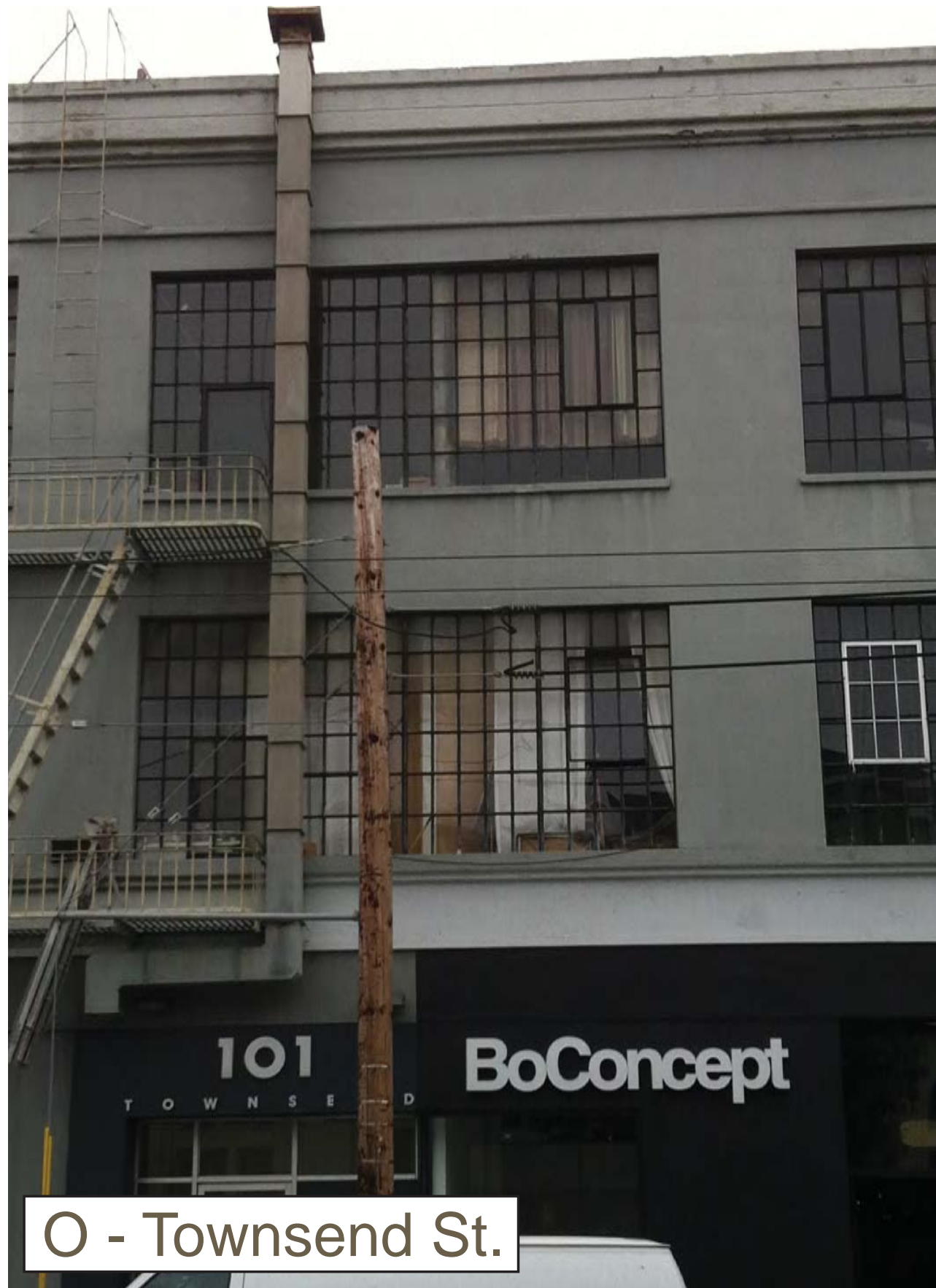

O - Townsend St.



P - Townsend St.



EXISTING EXTERIOR WINDOWS
101 TOWNSEND, SAN FRANCISCO



JOB NO. 900.002
DATE 03-12-2014

W.9



EXISTING EXTERIOR WINDOWS
101 TOWNSEND, SAN FRANCISCO



JOB NO. 900.002
DATE 03-12-2014

W.10



EXISTING INTERIOR WINDOWS
101 TOWNSEND, SAN FRANCISCO



JOB NO. 900.002
DATE 03-12-2014

W.11



EXISTING INTERIOR WINDOWS
101 TOWNSEND, SAN FRANCISCO



JOB NO. 900.002
DATE 03-12-2014

W.12

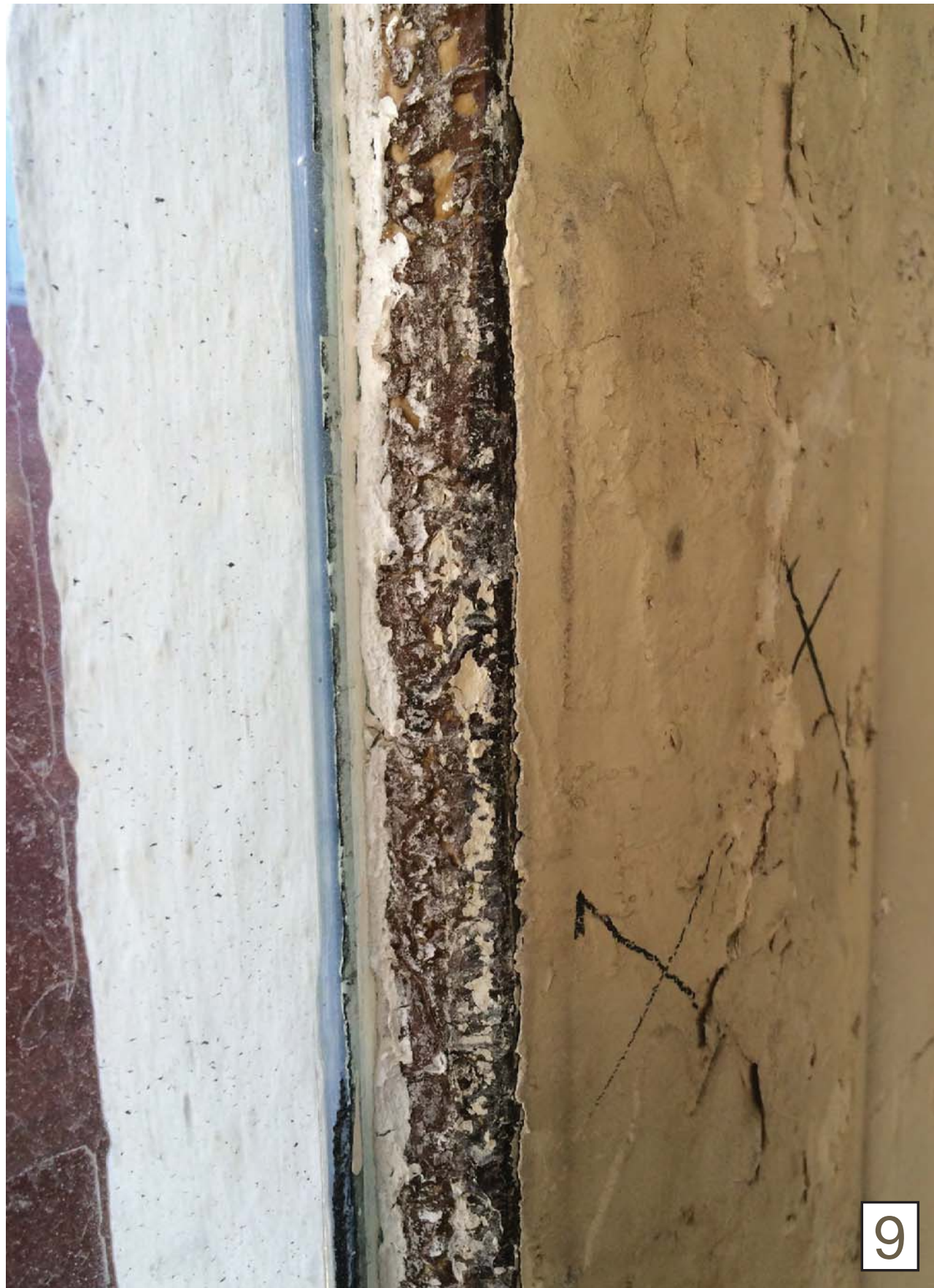

EXISTING INTERIOR WINDOWS
101 TOWNSEND, SAN FRANCISCO



JOB NO. 900.002
DATE 03-12-2014

W.13



888 BRANNAN - CUSTOM WINDOW #8300 HISTORIC SERIES
101 TOWNSEND, SAN FRANCISCO



JOB NO. 900.002
DATE 03-12-2014

W.14

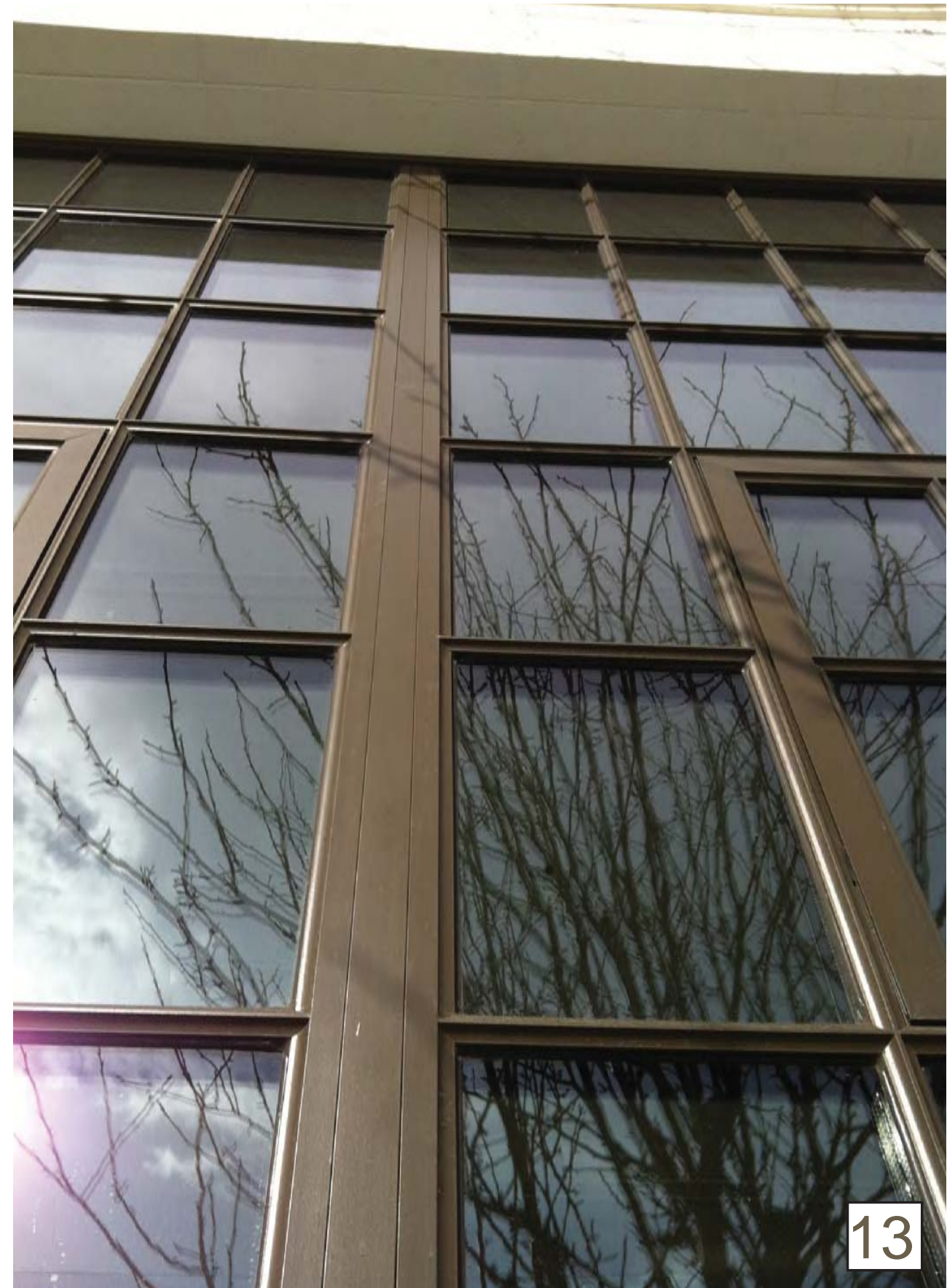

888 BRANNAN - CUSTOM WINDOW #8300 HISTORIC SERIES
101 TOWNSEND, SAN FRANCISCO



JOB NO. 900.002
DATE 03-12-2014

W.15

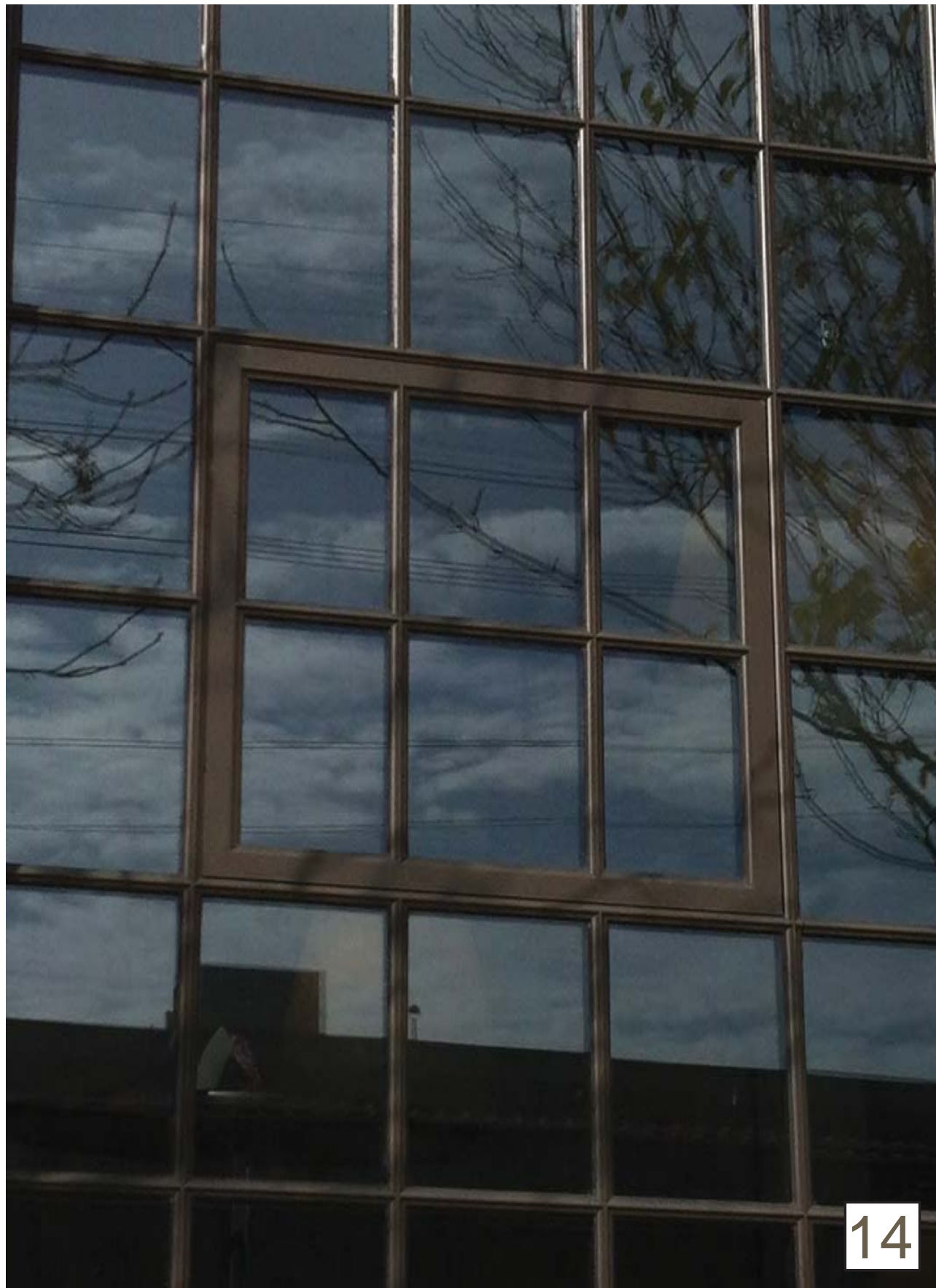

888 BRANNAN - CUSTOM WINDOW #8300 HISTORIC SERIES
101 TOWNSEND, SAN FRANCISCO



JOB NO. 900.002
DATE 03-12-2014

W.16



8300 Series Historical Fixed and Projected Aluminum Windows



Historically accurate preservation demands more than just a nod to the architectural vernacular - Respectful restoration calls for replication of character-defining features. Narrow sightlines, true divided lite muntin grids, and strict attention to detail set apart the fenestration of landmark structures - Then, and now.



by Wausau

Custom
Window™

Features

- Fluted, stepped "T", beveled or ogee perimeter glazing rebates to match existing putty-glazed windows
- AAMA AW-100 Architectural Performance Class - Grids designed for project-specific wind loads
- 3-1/2" frame depth with polyurethane or polyamide thermal barrier (8300i Series)
- Welded frame and true muntin grid construction, corner-blocked and hydraulically crimped vents
- 0.094" extrusion wall thickness
- Fixed; in- or out-swing casement (pictured); top-hinged, awning or hopper vents
- Custom profiles can be designed for panning, perimeter framing or muntins

8300 Series Historical

Fixed and Projected Aluminum Windows



Options

- Optional between-glass blinds with 5/8" aluminum slats
- Extra-wide thermal barrier (8300i) option for energy savings and condensation resistance
- Dual-color frame finishes
- Applied muntin grids optional at exterior, interior and/or between glass
- Panning systems with "T" mullions to echo existing profiles
- Head, jamb and sill receptors with stacking mullions
- More than 30,000 color choices in ultra-low VOC paints, or VOC-free anodize finishes
- Frosty matte eco-friendly anodize is ideal for recycled aluminum - Patina-free copper anodize available

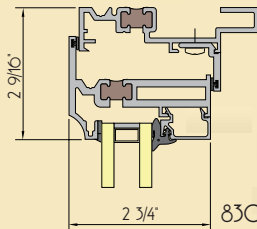

8300 Series
Fluted Profile
Poured Thermal

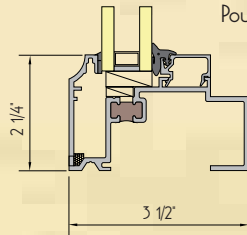
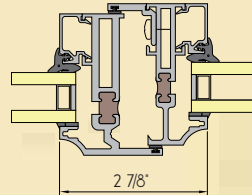

8300i Series
"T" Profile
I-Strut™ Thermal

Test results may vary with size, grids and hardware used.

Allowable Air	Water	NFRC U-Factor	CRF _f	STC
0.10 cfm/sqft at 6.24 psf	12 psf	0.38 to 0.73 BTU/hr.sqft.°F (est.)	43 to 58 (est.)	31 to 40 26 to 33 OITC

True Divided Lite Muntin Grids

Glassmaking technology in the years prior to World War II limited the size of individual glass lites, mitigating the use of putty-glazed muntin grids. Only true divided lite (TDL) design can reproduce this aesthetic with the fidelity required for rigorous historical preservation. For more than 30 years, Custom Window has been matching the appearance of existing sash in the nation's most prestigious landmarks.

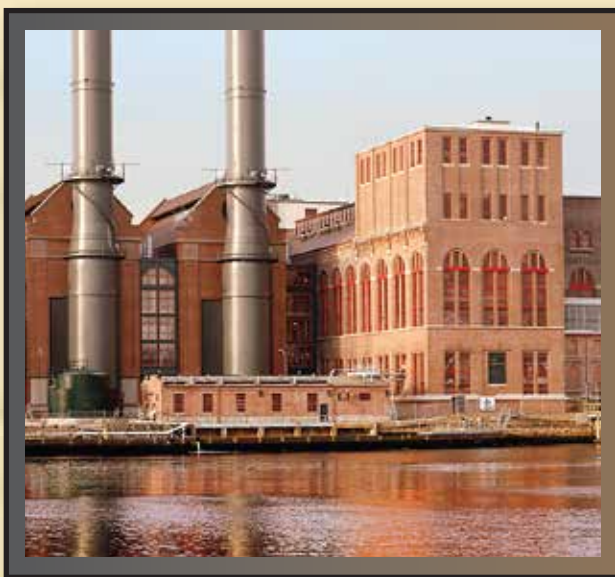
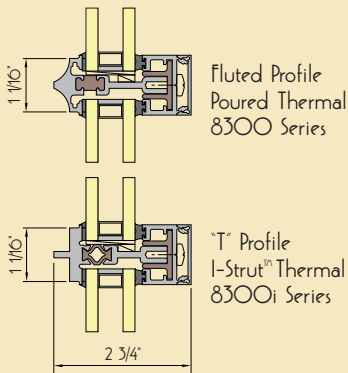

- 1-1/16" sightline at thermal barrier muntins
- 7/8" sightline at non-thermal barrier muntins
- Interior access for re-glazing standard, outside glazed options available
- Requires only small, low-cost replacement insulating glass units in case of vandalism
- Factory-applied silicone cap beads at exterior, glazing rebates drained to base
- Complies with industry standard deflection limits - Reduced glass bite and edge clearance for minimum sightline
- TDL muntin grids will affect NFRC U-Factor - Check local codes for historical building requirements

www.customwindow.com

Download comprehensive details, specifications and product performance information.

 Custom
Window™
by Wausau



"Custom Window" is a trademark of Apogee Wausau Group, Inc.
All rights reserved. © 2013 Apogee Wausau Group, Inc.

Featured Projects:

On the Cover:

The Palladian
San Diego, California
Walt Smyk Development

Inside right:

Manchester Street Power Station
Providence, Rhode Island
William Warner & Robinson Green Bereta, Architects

There's a reason so many of our nation's most important buildings, from art museums to elementary schools have Wausau windows...

For more than 55 years, Wausau has set the standard for performance, quality and ease of installation.

Wausau engineering professionals ensure that each building's windows are right for its needs, such as pre-engineered school windows, architectural grade hospital windows or customized, historically accurate replacements.

Wausau supports your sustainable design goals, and offers an industry-leading product warranty of up to 10 years.



2727 South Santa Fe Drive Englewood, CO 80110
Toll Free 1 800 255 1820 Fax 1 303 722 1993
email info@wausauwindow.com
customwindow.com



7800 International Drive Wausau, WI 54401
Toll Free 1 877 678 2983 Fax 1 715 843 4350
email info@wausauwindow.com
wausauwindow.com